

Anyone requiring reasonable accommodation to attend and/or fully participate in this meeting must contact Brandon Bundy at 739-1213 or [bbundy@midwestcityok.org](mailto:bbundy@midwestcityok.org) at least 24 hours prior to the scheduled starting time of the meeting.

**AGENDA FOR THE  
AMERICANS WITH DISABILITIES ACT (ADA) TRANSITION COMMITTEE  
SPECIAL MEETING**

May 23<sup>rd</sup>, 2022 – 6:30 P.M.  
Council Chambers  
100 N Midwest Boulevard

**CALL TO ORDER**

**MINUTES**

- 1) Discussion and consideration of approving the Minutes from the meeting held November 8<sup>th</sup>, 2021.

**NEW MATTERS**

- 1) Discussion of the July 4<sup>th</sup> Tribute to Liberty
- 2) Discussion of Council Chamber and Bathroom Remodeling Project
- 3) Discussion and consideration of a status report of the Midwest City ADA Transition Plan.
- 4) Discussion and consideration of recommending that the City change the minimum sidewalk width from 4' to 5'.
- 5) Discussion of ADA Committee member reappointments

**NEW BUSINESS**

**ADJOURN**



The City of  
MIDWEST CITY  
COMMUNITY DEVELOPMENT DEPARTMENT  
ENGINEERING DIVISION

Billy Harless, Community Development Director  
Brandon Bundy, P.E., City Engineer

ENGINEERING DIVISION  
Brandon Bundy, P.E., City Engineer  
CURRENT PLANNING DIVISION  
Kellie Gilles, AICP, Planning Manager  
COMPREHENSIVE PLANNER  
Petya Stefanoff, Comprehensive Planner  
BUILDING INSPECTION DIVISION  
Building Official

Notice of the Midwest City ADA Transition Committee Special meeting was filed for the calendar year with the Midwest City Clerk and a copy of the agenda for the meeting was posted in the lobby of City Hall at least 24 hours in advance of the meeting.

**MINUTES OF MIDWEST CITY  
Americans with Disabilities Act (ADA) Transition Committee  
November 8<sup>th</sup>, 2021 – 6:30 p.m. City Council Chambers**

The Special meeting of the Midwest City ADA Transition Committee was held at the City Council Chambers, 100 N. Midwest Blvd, Midwest City, Oklahoma County, on May 10, 2021 at 6:30 p.m., with the following members:

Commission Members: Max Wilson, Chairman  
Christine Price Allen, City Council  
Dean Hinton, Planning Commission  
Earl Foster  
Clint Reininger  
John Reininger

Absent: Rick Lewis, Vice Chair

Staff: Brandon Bundy, P.E., City Engineer  
Ashley; ASL Interpreter (contracted)

**CALL TO ORDER**

Chairman M. Wilson called the meeting to order at 6:34 p.m.

**MINUTES**

A motion to approve the minutes was made by D. Hinton and seconded by E. Foster. Motion carried.

**NEW MATTERS**

1) Discussion of a status report of the Midwest City ADA Transition Plan.

*M. Wilson asked for any updates regarding his request for accessible picnic tables in Joe B Barnes Regional Park. B. Bundy said he would get back with the Public Works Department and request and update for the May 2022 meeting.*

*C. Reininger asked about accessible paths and if we could get wider sidewalks. A long discussion ensued regarding the needs of the disabled community, ADA requirements, and the politics of the developers/home builders who generally are opposed. B. Bundy stated that there was an ordinance prepared to widen the city requirement from 4' to 5' but has not been heard by Council. B. Bundy said that if the desire of the committee was for wider sidewalks, on the May 2022 agenda there would be a matter to consider to recommend as a committee that the City adopt wider sidewalks.*

*The committee in general asked that they be considered when conceptual plans are drawn for park and building projects and that they would like to be invited along on tours and/or grand openings.*

*B. Bundy asked the committee if they knew of any hearing impaired type training to recommend to other departments.*

- 2) Discussion and Consideration of Setting the dates for the 2022 ADA Transition Committee  
*Discussion for the 2022 dates. M Wilson suggested we keep to a similar schedule since everyone has been able to attend. Staff suggested that the venue remain the Council Chambers with the future remodeling project coming up. C. Price Allen moved to schedule the 2022 meetings for 05/02/22 and 11/07/22 both at 6:30 PM and in the Council Chambers. E. Foster seconded the motion. Motion carried.*

**NEW BUSINESS**

*C. Reininger said that he attended the Tribute to Liberty and it was “great”; asking that staff be thanked for their hard work.*

**ADJOURN**

D. Hinton motioned to adjourn. Motion seconded by E. Foster. Adjourned at 8:14 p.m.

Minutes Approval

---

Date



**Engineering and  
Construction Services**  
100 N Midwest Boulevard  
Midwest City, OK 73110  
Office 405.739.1220

---

TO : ADA Transition Plan Committee

FROM : Brandon Bundy, P.E., Director

DATE : May 23, 2022

SUBJECT : Discussion of the July 4<sup>th</sup> Tribute to Liberty

---

Staff from the Communications and Marketing Department will be attending the meeting to brief the committee on the latest plans for the upcoming Tribute to Liberty event held in Joe B. Barnes Regional Park.

No Action needed on this item.

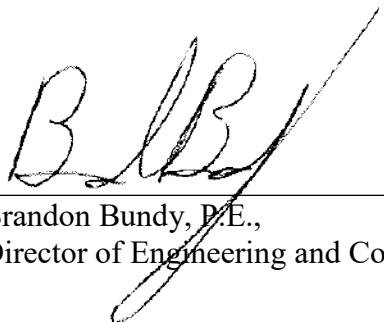

---

Brandon Bundy, P.E.,  
Director of Engineering and Construction Services



**Engineering and  
Construction Services**  
100 N Midwest Boulevard  
Midwest City, OK 73110  
Office 405.739.1220

---

TO : ADA Transition Plan Committee

FROM : Brandon Bundy, P.E., Director

DATE : May 23, 2022

SUBJECT : Discussion of Council Chamber and Bathroom Remodeling Project

---

March 8<sup>th</sup>, 2022; the City of Midwest City received 4 bids for the Council Chamber and Bathroom Remodeling Project. Of the bids, Downey Contracting was the lowest and best bid. On March 22<sup>nd</sup>, 2022 City Council reviewed the bid and awarded the project to Downey Contracting in the amount of \$668,000. Included in the award were alternates to update light fixtures in the chamber, add a generator circuit, and renovate the downstairs bathroom. This is above and beyond the base bid of renovating the Council Chamber and court bathrooms for ADA compatibility. A pre-construction conference was held with Downey Contracting on April 29<sup>th</sup>, 2022 with discussions regarding schedule and mobilization. As of the writing of this memo we are still waiting on a final schedule. Downey Contracting has been moving forward with selecting materials and ordering; construction is anticipated to start sometime in July 2022.

No Action needed on this item.

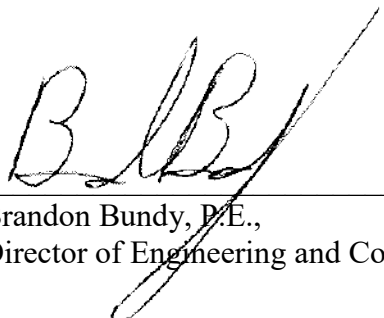

---

Brandon Bundy, P.E.,  
Director of Engineering and Construction Services



**TO :** ADA Transition Plan Committee  
  
**FROM :** Brandon Bundy, P.E., Director  
  
**DATE :** May 23, 2022  
  
**SUBJECT :** Discussion and consideration of a status report of the Midwest City ADA Transition Plan.

The ADA Transition Plan was drafted and adopted in 2015. This plan is utilized by staff to prioritize projects based on the limited funding available and is scored on factors such as cost, public priority, safety, and citizen generated. Occasionally, we do get opportunities to address items further down the list as part of a larger project but in general, we only are able to focus on the top few. Attached is the list showing the top 20 projects.

Below are a few of the completed projects since last meeting, November 2021.

<b>Project</b>	<b>Improvement</b>	<b>Funding</b>
<b>West Palmer Loop Trail</b>	Multi-purpose paved trail 1.4 miles in length	TAP Federal Funding
<b>Safe Routes to School (just south of Midwest Elementary from Midwest Blvd to Key Blvd)</b>	Multi-purpose paved trail	Safe Routes to School
<b>Douglas Blvd / SE 15<sup>th</sup> St Intersection</b>	Added push buttons at all ramps	ODOT Safety Funding
<b>Midwest Blvd / Steed Dr Intersection</b>	Added accessible ramps and push buttons for all directions	ODOT Safety Funding
<b>Midwest Blvd / General Senter Dr Intersection</b>	Added accessible ramps and push buttons for all directions	ODOT Safety Funding
<b>Midwest Blvd / Reno Ave Intersection</b>	Added accessible ramps and push buttons for all directions	ODOT Safety Funding
<b>Reno Ave / Parklawn Ave Intersection</b>	Added accessible ramps and push buttons for all directions	ODOT Safety Funding
<b>Reno Ave / Bella Vista / Key Blvd Intersection</b>	Added accessible ramps and push buttons for all directions	ODOT Safety Funding
<b>Reno Ave / Glenhaven Dr Intersection</b>	Added accessible ramps and push buttons for all directions	ODOT Safety Funding

Below is a list of projects pending or currently underway.

<b>Project</b>	<b>Improvement</b>	<b>Funding</b>
<b>Midwest Blvd / NE 23<sup>rd</sup> St Intersection</b>	Add accessible ramps and push buttons for all directions	ODOT Safety Funding
<b>Air Depot Blvd / NE 23<sup>rd</sup> St Intersection</b>	Add accessible ramps and push buttons for all directions	ODOT Safety Funding
<b>Air Depot Blvd / NE 10<sup>th</sup> St Intersection</b>	Add accessible ramps and push buttons for all directions	ODOT Safety Funding
<b>Douglas Blvd / Wonga Dr Intersection</b>	Add push buttons at all ramps	ODOT Safety Funding
<b>Library Sidewalk</b>	New sidewalk from Reno Ave to Library in City Complex	CDBG Grant
<b>Council Chamber Remodeling</b>	Remodel Council Chamber, Court Bathroom, and Basement Bathroom	City / ARPA Funding
<b>WP Bill Atkinson Park</b>	New Park	2018 Bond
<b>Reno Ave Resurfacing from Midwest Blvd to Blake Dr</b>	Replace pedestrian bridge over Soldier Creek, reconstruct asphalt trail, fix major sidewalk issues along corridor	STBG Federal Funding
<b>Connector Trail</b>	Multi-purpose paved trail connecting Palmer Loop and Safe Routes with a signalized pedestrian crossing	TAP Federal Funding
<b>Rail with Trail Phase 2 &amp; 3</b>	Multi-purpose paved trail from Midwest City High School to Quinlan Park	TAP Federal Funding
<b>NE 10<sup>th</sup> St sidewalk</b>	Goal to have continuous sidewalk from Douglas Blvd to Post Rd	Sidewalk Funding

Staff is available for any questions,

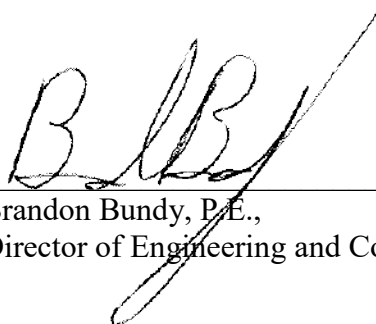

---

Brandon Bundy, P.E.,  
 Director of Engineering and Construction Services

# ADA Transition Plan Midwest City

Rank	Category	Primary Location	Sub Location	Violation	Staff Comments
1	Accessible Route	Major intersections	Signals city-wide	Stoplight signal buttons exceed ADA height	Since 2015, Engineering has upgraded at least 50 signals to ADA standards.
2	Accessible Route	Original Mile - W Fairchild, W Lockheed, Rickenbacker	Sidewalk	Gaps, curbing	Staff has requested funding
3	Parking	City Hall	North Parking Lot	Accessible aisle & Lacking ADA parking space - Van	
4	Parking	City Hall	South Parking Lot	No Van Space or access isle	
5	Entrance	City Hall	Main entrance	Running slope exceeds max - front entrance	
6	Park Amenities	Joe B Barnes Park	route at ballfield	Maintain routes	
7	Accessible Route	Joe B Barnes Park	Restroom	Running slope exceeds max	
8	Park Amenities	Joe B Barnes Park	Playground and ball field	Running slope exceeds max, Rebuild stairs	
9	Training	Staff		Sensitivity training needed for employees that interact with public	Ongoing - yearly
10	Accessible Route	City Hall / Fire Dept	Sidewalk	Ramps along Reno	To be fixed with Federal Aid Project 2021
11	Hallway	City Hall	Doors-Whole building	Doors do not meet standards for compliant hardware.	Mostly door knob hardware
12	Accessible Route	City Hall	Council Chambers	Number of handrails on ramp & Steps	City has construction plans in hand, trying to build funding
13	Accessible Route	Joe B Barnes Park	pavilion	Accessible path to pavilion	Sidewalk either missing, barriers such as curb, or sidewalk not adequate for ADA. Can be packaged with other work in park.
14	Park Amenities	Joe B Barnes Park	small playground & large playground	Playground surface not ADA compliant	Common issue throughout the City. Could be packaged with other playgrounds.
15	Park Amenities	Joe B Barnes Park	dugout	Level change - dug out	Grading and small amount of concrete work can alleviate most issues
16	Park Amenities	Joe B Barnes Park		Level change - Picnic Table	Unknown how many picnic tables, grading and small amount of concrete work can alleviate most issues
17	Accessible Route	Joe B Barnes Park	soccer field concession stand	Running slope exceeds max	Soccer Field Concession Stand
18	Parking	Community Center	Parking lot	Cross slope exceeds max	
19	Accessible Route	Dana Brown Head Start		Barrier to playground	
20	Hallway	Dana Brown Head Start		Need visual strobe alarms	



---

TO : ADA Transition Plan Committee

FROM : Brandon Bundy, P.E., Director

DATE : May 23, 2022

SUBJECT : Discussion and consideration of recommending that the City change the minimum sidewalk width from 4' to 5'.

---

At the last ADA Transition Plan Committee meeting November 8, 2021; the committee inquired about the width minimum for City sidewalks. Staff informed them of efforts being done to change the ordinance to require a width of 5' over the current 4'. Since that meeting, the City's Sidewalk Committee met and recommended that we move to a 5' minimum width. As of today, the Ordinance Oversight Committee has seen the following ordinance request but did not take formal action.

City Staff is requesting amendment of the existing ordinance Midwest City code, Chapter 37, Streets and Sidewalks, Article III, Section 37-67, Construction of Sidewalk. During discussion with staff and elected officials; there has been some discussion as to what is the appropriate width of the sidewalk. Currently, the code requires a minimum sidewalk width of 4'.

The 2010 ADA Standards for Accessible Design are the current federal standard regarding ADA requirements. Sidewalks on public right of way are under the jurisdiction of the Public Rights-of-Way Access Advisory Committee (PROWAG)

- R302.3 Continuous Width: Except as provided in R302.3.1 and R302.3.2, the continuous clear width of pedestrian access routes shall be 4.0 ft minimum, exclusive of the width of the curb.
- R302.4 Passing Spaces: Where the clear width of pedestrian access routes is less than 5.0 ft, passing spaces shall be provided at intervals of 200.0 ft maximum. Passing spaces shall be 5.0 ft minimum by 5.0 ft minimum. Passing spaces are permitted to overlap pedestrian access routes.

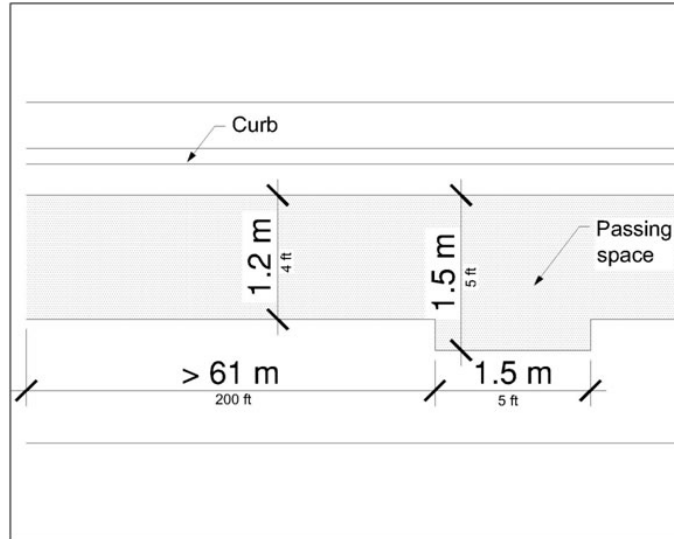

Therefore, our current code does not address the absolute minimum as set that there be passing spaces. To simplify code, staff recommends that the minimum be set at 5' wide. In practice, for the past 8 years, all sidewalks constructed under guidance of Community Development have had a typical 5' wide cross section minimum. Our own ADA Transition Committee has discussed this very issue multiple times. 4' is simply too narrow for anyone to pass a wheelchair. It is also uncomfortable to walk side by side on anything less than 5'.

The updated code will bring the City into compliance with this standard. In addition to the revisions from ADA, we propose deleting the existing exhibit which is covered in depth by our construction standards as well as deleting the paragraphs related to grandfathering current subdivisions. When this ordinance was originally passed in 1986, sidewalks were not standard practice; since that time, all subdivisions and commercial are required to have sidewalks unless waived by Council. As such, the old paragraphs related to the original passing need to be deleted to eliminate confusion.

Brandon Bundy, P.E.,  
 Director of Engineering and Construction Services



**Engineering and  
Construction Services**  
100 N Midwest Boulevard  
Midwest City, OK 73110  
Office 405.739.1220

---

TO : ADA Transition Plan Committee

FROM : Brandon Bundy, P.E., Director

DATE : May 23, 2022

SUBJECT : Discussion of ADA Committee member reappointments

---

The appointments of Max Wilson and Rick Lewis are set to expire on December, 13<sup>th</sup>, 2022. Staff asks that those members consider if they would like to be reappointed so that the proper agenda can be drafted. The reappointment will happen sometime around November so an immediate response is not required and staff will send a reminder this fall.

No Action needed on this item.

---

Brandon Bundy, P.E.,  
Director of Engineering and Construction Services