



MIDWEST CITY

MEETING AGENDAS FOR

May 14, 2019



The 6:00 PM meetings will be shown live on Channel 20 and streamed live on YouTube.



The recorded video will be available on YouTube and the City's website within 48 hours at www.youtube@midwestcityok.org.



The meeting minutes and video can be found on the City's website in the Agenda Center: <https://midwestcityok.org/AgendaCenter>.



To make a special assistance request, call 739-1215 or email pmenefee@midwestcityok.org no less than 24 hours prior to the start of a meeting. If special assistance is needed during a meeting, call 739-1388.



The Council will go directly into the City meetings down in the Council Chambers of City Hall at 6:00 PM. However, they will informally gather at or after 5:00 PM in the second floor conference room for dinner, but no City Council business will be discussed or acted upon and the room will be open to the public. Meals will only be provided to the City Council and staff.



CITY OF MIDWEST CITY COUNCIL AGENDA

City Hall - Midwest City Council Chambers, 100 N. Midwest Boulevard

May 14, 2019 – 6:00 PM

A. CALL TO ORDER.

B. OPENING BUSINESS.

- Invocation by Public Works Director Vaughn Sullivan
- Pledge of Allegiance by Councilmember Susan Eads
- Community-related announcements and comments
- Mayoral Proclamation for Retiree Chris Whitlow and "Kids to Parks Day"

C. CONSENT AGENDA. These items are placed on the Consent Agenda so the Council, by unanimous consent, can approve routine agenda items by one motion. If any item proposed does not meet with the approval of all Council, or members of the audience wish to discuss an item, it will be removed and heard in a regular order.

1. Discussion and consideration of approving the minutes of the special meeting of April 16, 2019 and the regular meeting of April 23, 2019, as submitted. (City Clerk - S. Hancock)
2. Discussion and consideration of supplemental budget adjustments to the following funds for FY 2018-2019, increase: General Fund, expenses/Transfers Out (00) \$804,267. Police Fund, revenue/Transfers In (00) \$320,286. Fire Fund, revenue/Transfers In (00) \$259,010. General Fund, expenses/Transfers Out (00) \$2,520. CDBG Fund, revenue/Transfers In (00) \$2,520. General Fund, expenses/Street (09) \$58,547. Hotel/Motel Fund, expenses/Transfers Out (87) \$4,369. Park and Rec Fund, revenue/Transfers In (00) \$611. CVB Fund, revenue/Transfers In (00) \$2,447. Welcome Center Fund, revenue/Transfers In (00) \$1,311. Customer Deposits Fund, revenue/Investment Interest (00) \$5,278; expenses/Transfers Out (00) \$5,278. Municipal Court Fund, revenue/Investment Interest (00) \$225; expenses/Transfers Out (00) \$225. General Fund, revenue/Transfers In (00) \$225. L&H Fund, expenses/Personnel (03) \$377,018. General Fund, revenue/Transfers In (00) \$224,971. Sales Tax Capital Improvement Fund, expenses/Transfers Out (00) \$227,366. Capital Improvements Fund, revenue/Transfers In (00) \$91,963. Sooner Rose TIF Fund, expenses/None (00) \$1,221; expenses/Hospital Authority (90) \$65,000. General Gov't Sales Tax Fund, expenses/City Manager (01) \$750. Fire Fund, expenses/Fire (64) \$270,580. Grants Fund, revenue/Intergovernmental (88) \$75,619; expenses/Transfers Out (88) \$75,619. Disaster Relief Fund, revenue/Transfers In (88) \$75,619. Capital Improvements Fund, expenses/Capital Improvements (57) \$8,000. Fire Fund, expenses/Fire (64) \$36,000. 2018 Election G.O. Bonds Fund, expenses/Fire (64) \$1,272; expenses/Emergency Operations (21) \$26,198. Decrease: 2018 Election G.O. Bonds Fund, expenses/Park & Rec (06) \$94,104; expenses/General Government (14) \$26,703; expenses/29th Street (92) \$60,910; expenses/Animal Control (10) \$3,142. (Finance - C. Barron)

3. Discussion and consideration approving a resolution for the City Council of the City of Midwest City relating to the expenditure of approximately \$17,000 of the total police/fire joint training facility bond project and \$19,000 of the total fire station remodel bond project for the payment of professional program management services; indicating the official action of the City Council for the reimbursement to Midwest City Fire Department's 040 Fund balance of such expenditure by the issuance of tax exempt general obligation bonds of the City of Midwest City, previously authorized at an election held for that purpose on August 28, 2018 authorizing the payment of professional services. (Finance - C. Barron)
4. Discussion and consideration of accepting the monthly report on the City of Midwest City Employees' Health Benefits Plan by the City Manager and action as deemed necessary by the Council to maintain the plan. (Human Resources - C. Wilson)
5. Discussion and consideration of renewing the Consulting Agreement with Gallagher Benefit Services Inc. in the amount of \$55,560 to include the coordination and management of benefit services, serving as the liaison with PlanSource to provide an electronic platform for streamlining benefit enrollments and information, and for the coordination and management of the Section 125 Flexible Spending Plan (Cafeteria Plan) with Discovery Benefits for the 2019-20 fiscal year. (Human Resources - C. Wilson)
6. Discussion and consideration of renewing for the Fiscal Year 2019/2020 contracts with DB Compensation Software in the amount of \$2,000.04 to maintain the City's non-represented employees' compensation plan and job descriptions. There is no cost increase over last year. (Human Resources - C. Wilson)
7. Discussion and consideration of entering into a contract to provide employee assistance and related services with Dan L. Benton, Licensed Professional Counselor for FY 2019/2020 to provide the Employee Assistance Program and related services to City employees at the rate of \$2.25 per employee per month, \$106.83 per initial assessment and \$62.44 per session. (Human Resources - C. Wilson)
8. Discussion and consideration of entering into a contract to provide employee assistance and related services with Stacey A. Stephens, a Licensed Professional Counselor (LPC) for the FY 2019/2020 to provide the Employee Assistance Program (EPA) and related services at the rate of \$2.25 per employee per month, \$106.83 charge per initial assessment and \$62.44 per session. In addition Ms. Stephens will provide lead or assistance to lead counselor in conducting post critical incident group debriefing services at a fee of \$100 per debrief, as requested by the City. (Human Resources - C. Wilson)
9. Discussion and consideration of approving and entering into an agreement in the amount of \$6,000 with Production Essentials, LLC to provide a sound system and sound system services associated with entertainment in Regional Park as part of the 2019 Tribute to Liberty 4th of July celebration. (Parks & Recreation - F. Gilles)
10. Discussion and consideration of approving and entering into an agreement with Dr. Irvin L. Wagner, Professor of Music at University of Oklahoma, in the amount of \$12,000, for a 50-piece concert band to provide the headliner entertainment in Regional Park as part of the 2019 Tribute to Liberty 4th of July celebration. (Parks & Recreation - F. Gilles)

11. Discussion and consideration of renewing the Memorandum of Understanding with the Oklahoma Department of Mental Health and Substance Abuse Services for FY 2019/2020 in an amount not to exceed \$25,000, which establishes the terms and conditions under which the City participates in this program to identify eligible municipal offenders in Midwest City who are in need of behavioral health treatment services and fund supplies necessary to operate the screening program such as a computer or drug testing supplies in the amount of \$1,000. (Police - B. Clabes)
12. Discussion and consideration of accepting maintenance bonds from Mid-South Contracting, L.L.C. in the amount of \$1868.50 for the sewer line improvements located at 5600 Tinker Diagonal. (Community Development - P. Menefee)
13. Discussion and consideration of approving and entering into a contract in an amount not to exceed \$6,500.00 for fiscal year 2019-2020 with THICK DESCRIPTIONS ("TD") to establish the terms and conditions under which THICK DESCRIPTIONS will provide an extended week long S.T.E.A.M. (Science, Technology, Engineering, Anthropology, and Math) camp to NIA Youth Summer Camp participants. (Neighborhood Services - M. Stroh)
14. Discussion and consideration of approving and entering into a contract in an amount not to exceed \$2,200.00 for fiscal year 2019-2020 with Crutch Public School to establish the terms and conditions under which Crutch Public School will provide a school bus and driver for NIA Youth Summer Camp. (Neighborhood Services - M. Stroh)
15. Discussion and consideration declaring the following items as surplus: (2) Vacuums; (1) Storage Cabinet; (2) Storage Drawers; (7) Light Fixtures; (1) Air Compressor; (2) Full Length Mirrors; (6) Lobby Chairs; (4) Flush Mount Stainless Paper Towel Dispensers; (5) Toilet Paper Holders Stainless; (4) Soap Dispensers Stainless, and authorizing their disposal by public auction, sealed bid, or destruction, if necessary. (Community Development - B. Harless)
16. Discussion and consideration of declaring (1) 2008 Chevrolet 2500 Animal Welfare Truck and (1) 2006 Simulated Impaired Driving Experience, as surplus and authorizing their disposal by public auction, sealed bid or destruction, if necessary. (Police - B. Clabes)
17. Discussion and consideration of declaring the following equipment from Street Department: (2) Stihl weed eaters, (2) Stihl back pack blowers, (1) One Stihl blower vacuum and (1) One Stihl chain saw, as surplus and authorizing their disposal by sealed bid, public auction, or by other means as necessary. (Public Works - V. Sullivan)
18. Discussion and consideration of declaring surplus (8) Whelen Vortex 1 sirens and (2) Whelen Vortex R4 sirens and putting them up for public auction, sealed bid or destruction, if necessary. (Emergency Management - M. Bower)

D. DISCUSSION ITEMS.

1. (PC – 1990) Discussion and consideration of approval of the proposed preliminary plat of Cassidy Cove Section III, described as a part of the NW/4 of Section 1, T11N, R2W, located at 500 and 600 Davidson Road. (Continued from April 23, 2019 Council meeting.) (Community Development - B. Harless)
2. Consider and adopt an ordinance providing for the issuance of General Obligation Bonds in the sum of Seventeen Million Two Hundred Fifty Thousand and no/100s Dollars (\$17,250,000.00) by the City of Midwest City, Oklahoma authorized at an election duly called and held for such purpose: Prescribing Form of Bonds; Providing for registration thereof; Providing for a system of registration for uncertificated registered public obligations; Providing levy of an annual tax for payment of principal and interest on the same; fixing other details of the issue; and Declaring an Emergency. (City Manager - G. Henson)
3. Consider and award of the sale of General Obligation Bonds of the City of Midwest City, Oklahoma in the amount of Seventeen Million Two Hundred Fifty Thousand and no/100s dollars (\$17,250,000.00) to the lowest bidder. (City Manager - G. Henson)
4. Discussion and consideration of 1) approving a change order in the amount of \$22,770.00 with SafetyCom, Inc. for additional equipment to encrypt the outdoor warning sirens, and 2) purchasing the necessary encrypted radio equipment from Total Radio in the amount of \$29,973.24 per the Oklahoma State Wide Contract #SW1053M, Public Safety Communication Equipment - Motorola Solutions. (Emergency Management - M. Bower).
5. Discussion and consideration of approving and awarding proposal to Tyler Technologies for their Brazos' eCitation and eCrash Solutions, who submitted the only bid, in the amount of \$23,557.00 (five year total includes \$564 annual maintenance) for one device, and \$6,500.00 for software modules with a \$1,300 annual maintenance. (Police - B. Clabes)
6. Discussion and consideration of 1) purchase and installation of Kenwood/EF Johnson P25 radios for the Fire department in the amount of \$283,588.34 from the Oklahoma County contract #CW19044 with Stolz Telecom LLC and 2) approving the resolution authorizing the purchase and installation of Kenwood/EF Johnson P25 radios per Oklahoma County contract #CW19044 with Stolz Telecom LLC. (Information Technology - R. Rushing)
7. Discussion and consideration of awarding the bid and entering into a contract with Casco Industries for New Self Contained Breathing Apparatus (SCBA) and associated, bid upon, equipment and optional accessories, in a total amount of \$436,875. (Fire Chief - B. Norton)
8. Discussion and consideration of awarding the bid and entering into a contract with Tescorp for two (2) Self Contained Breathing Apparatus Air Compressor Fill Stations at \$41,576.00 each and (2) Integrated Carbon Monoxide Detectors at \$2,900.00, in the total amount of \$88,952.00, to be placed at Fire Stations No. 1 and 6. (Fire - B. Norton)

9. Discussion and consideration of appointing representatives from Midwest City to an advisory committee that would oversee efforts related to a pilot study for Indirect Potable Reuse (IPR) by the City of Norman. (Public Works - R.P. Streets)

10. Discussion and consideration of appointing a replacement for Travis Jernigan to the Plumbing, Gas, and Mechanical Board. (Continued from April 23, 2019 Council meeting) (Community Development - B. Harless)

E. NEW BUSINESS/PUBLIC DISCUSSION. The purpose of the "Public Discussion Section" of the Agenda is for members of the public to speak to the City Council on any Subject not scheduled on the Regular Agenda. The Council shall make no decision or take any action, except to direct the City Manager to take action, or to schedule the matter for discussion at a later date. Pursuant to the Oklahoma Open Meeting Act, the Council will not engage in any discussion on the matter until that matter has been placed on an agenda for discussion. **THOSE ADDRESSING THE COUNCIL ARE REQUESTED TO STATE THEIR NAME AND ADDRESS PRIOR TO SPEAKING TO THE COUNCIL.**

F. EXECUTIVE SESSION.

1. Discussion and consideration of (1) entering into executive session, as allowed under 25 O.S., § 307(B)(4), to discuss *Shane Campbell v. the City of Midwest City*, Case No. CM-2017-01546126A and CM-2017-01548K, and (2) in open session, authorizing the city manager to take action as appropriate based on the discussion in executive session. (City Manager - T. Lyon)

G. FURTHER INFORMATION.

1. Discussion and consideration to approve an Ordinance amending the Midwest City Municipal Code, Chapter 28, Offenses, Section 28-130, Possession of Dangerous Drugs; Section 28-131, Possession and sale of certain toxins and other drugs prohibited, and Section 28-132, Possession or sale of drug related paraphernalia, and Providing for Repealer and Severability. (Police - B. Clabes)

2. Presentation of information by Dana Brockway, Executive Committee Legal Redress, NAACP Oklahoma City Branch. (City Attorney - H. Poole)

H. ADJOURNMENT.





CONSENT AGENDA



A notice for this Special Midwest City Council meeting was filed with the City Clerk of Midwest City at least 48 hours prior to the meeting. Public notice of this agenda was accessible at least 24 hours before this meeting at City Hall and on the Midwest City website (www.midwestcityok.org).

Midwest City Council Minutes

April 16, 2019 – 6:00 PM

This special meeting was held in the Midwest City Council Conference room on the second floor of City Hall, 100 N. Midwest Boulevard, Midwest City, County of Oklahoma, State of Oklahoma.

Mayor Matt Dukes called the meeting to order at 6:00 PM with the following members present: Councilmembers Susan Eads, Pat Byrne, Española Bowen, Sean Reed, Christine Allen, and Jeff Moore with Acting City Clerk Guy Henson. Absent: none.

DISCUSSION ITEM.

1. **Discussion and consideration of approving an engagement letter from Kathryn D. Terry for the purpose of negotiating the new City Manager's employment contract.** After discussion, Byrne made a motion to approve the engagement letter, as submitted, with the Mayor named as the Council's representative during negotiations, seconded by Allen. Voting aye: Eads, Byrne, Bowen, Reed, Allen, Moore and Mayor Dukes. Nay: none. Absent: none. Motion carried.

EXECUTIVE SESSION.

1. **Discussion and consideration of 1) entering into executive session as allowed under Title 25 §307(B)(1) discussing the employment, hiring, appointment or promotion for the new City Manager Position and 2) taking action as discussed in executive session.**

At 6:07 PM, Allen made a motion to enter into executive session, seconded by Eads. Voting aye: Eads, Byrne, Bowen, Reed, Allen, Moore and Mayor Dukes. Nay: none. Absent: none. Motion carried.

At 7:25 PM, Allen made a motion to return to open session, seconded by Eads. Voting aye: Eads, Byrne, Bowen, Reed, Allen, Moore and Mayor Dukes. Nay: none. Absent: none. Motion carried.

Reed made a motion to extend an offer of employment to Assistant City Manager Tim Lyon contingent upon the successful negotiation of a contract, seconded by Allen. Voting aye: Eads, Byrne, Bowen, Reed, Allen, Moore and Mayor Dukes. Nay: none. Absent: none. Motion carried.

ADJOURNMENT.

There being no further business, Mayor Dukes adjourned the meeting at 7:25 PM.

ATTEST:

MATT DUKES, Mayor

GUY HENSON, Acting City Clerk

A notice for the Midwest City Council meetings was filed for the calendar year with the City Clerk of Midwest City. Public notice of this agenda was accessible at least 24 hours before this meeting at City Hall and on the Midwest City website (www.midwestcityok.org).

Midwest City Council Minutes

April 23, 2019 – 6:00 PM

This meeting was held in the Midwest City Council Chambers at City Hall, 100 N. Midwest Boulevard, Midwest City, County of Oklahoma, State of Oklahoma. Mayor Matt Dukes called the meeting to order at 6:02 PM with the following members present: Councilmembers Susan Eads, Pat Byrne, Española Bowen, Sean Reed, Christine Allen, and Jeff Moore with City Clerk Sara Hancock, City Attorney Heather Poole, and City Manager Guy Henson. Absent: none.

OPENING BUSINESS. Public Works Director Vaughn Sullivan opened with the invocation, followed by the Pledge of Allegiance led by Mayor Dukes. Council and Staff made community-related announcements. Mayor Dukes presented the Elks Lodge's Youth Week and Police Week proclamations and Councilmember Eads presented an Earth Day proclamation.

CONSENT AGENDA. Allen made a motion to approve the consent agenda, as submitted, seconded by Eads. Voting aye: Eads, Byrne, Bowen, Reed, Allen, Moore and Mayor Dukes. Nay: none. Absent: none. Motion carried.

1. Discussion and consideration of approving the minutes of the regular meeting of April 9, 2019, as submitted.
2. Discussion and consideration of accepting the City Manager's Report for the month of March, 2019.
3. Discussion and consideration of supplemental budget adjustments to the following funds for FY 2018-2019, decrease: Disaster Relief Fund, revenue/Transfers In (88) \$25,950; expenses/Disaster Relief (88) \$55,975. 2018 Election G.O. Bond Fund, expenses/Transfers Out (21) \$25,950.
4. Discussion and consideration of accepting the Monthly Neighborhood Services report for March 2019.
5. Discussion and consideration of amending the engineering contract funding agreement for Federal-Aid Project Number TAP3-3269(004)AG, State Job Number 32269(05), with the Oklahoma Department of Transportation for the design services involving the City of Midwest City: Rail with Trail Phase 2 and 3 EC-1819D, for a total cost of \$114,500, with 80% paid by Federal STP funds (\$91,600) and 20% with City funds (\$22,900).
6. Discussion and consideration of accepting a grant of Permanent Waterline Easement from The Board of Trustees of the Oscar Rose Junior College, across a certain parcel of land located within the corporate boundaries of Midwest City being part of Lots 20 and 21 of Aviation Acres Subdivision, located in the Northwest Quarter (NW/4) of Section Nine (9) Township Eleven (11) North Range Two (2) West of the Indian Meridian, in Midwest City, Oklahoma County, Oklahoma.
7. Discussion and consideration of accepting maintenance bonds from H&H Plumbing and Utilities, Inc. in the amount of \$2,476.25 for the sewer line improvements located at 10225 Reno Ave.

8. Discussion and consideration of approving the potential expansion of the school resource officer program to Carl Albert High School and establishing the Mid-Del School System's participation in the FY 19/20 SRO program at \$70,000 for Midwest City High School and \$75,000 at Carl Albert High School.
9. Discussion and consideration of declaring miscellaneous office equipment and supplies, as surplus and authorizing their disposal by public auction, sealed bid or destruction, if necessary.

DISCUSSION ITEMS.

1. **(PC-1986) Public hearing with discussion and consideration of a request to rename Center Drive to Warren Drive.** After discussion, Eads made a motion to approve the request to rename Center to Warren Drive, as submitted, seconded by Reed. Voting aye: Eads, Byrne, Bowen, Reed, Allen, Moore and Mayor Dukes. Nay: none. Absent: none. Motion carried.

Staff made a request to postpone item number 2 and 4 as the applicant was not in attendance as of yet.

3. **(PC-1989) Discussion and consideration of approval of the Final Plat of Johnson Homestead, described as a part of the NW/4 of Section 7, T11N, R1W, located at 10433 SE 21st Street.** Bowen made a motion to approve the Plat, as submitted, seconded by Moore. Voting aye: Eads, Byrne, Bowen, Reed, Allen, Moore and Mayor Dukes. Nay: none. Absent: none. Motion carried.
5. **(PC – 1990) Discussion and consideration of approval of the proposed preliminary plat of Cassidy Cove Section III, described as a part of the NW/4 of Section 1, T11N, R2W, located at 500 and 600 Davidson Road.** No action was taken.
2. **(PC – 1988) Discussion and consideration of approval of the Replat of Lot 15, Block 21 of the Speckman Heights Addition, described as a part of the NW/4 of Section 10, T11N, R2W and addressed as 101 E. Kittyhawk Dr.** After Applicant, Jeff Johnson and Council had discussion; Eads made a motion to approve the replat, as submitted, seconded by Reed. Voting aye: Eads, Byrne, Bowen, Reed, Allen, Moore and Mayor Dukes. Nay: none. Absent: none. Motion carried.
4. **(PC-1991) Discussion and consideration of approval of the Replat of Lot 6, Block 5 of the Pine Addition, described as a part of the NE/4 of Section 10, T11N, R2W and addressed as 220 E. Kittyhawk Dr.** After Applicant, Jeff Johnson and Council had discussion, Eads made a motion to approve the replat, as submitted, seconded by Bowen. Voting aye: Eads, Byrne, Bowen, Reed, Allen, Moore and Mayor Dukes. Nay: none. Absent: none. Motion carried.
6. **Discussion and consideration of entering into and approving an Agreement for Professional Architectural Services with Selser Schaefer Architects from Tulsa, OK in the amount of \$178,695.00 to design the new single story Midwest City Animal Services Center of approximately 9,500 square feet with associated parking on the city property located at 2901 Woodside Drive. This is a General Obligation Bond project.** After discussion, Eads made a motion to enter into and approve the Agreement, as submitted, seconded by Reed. Voting aye: Eads, Byrne, Bowen, Reed, Allen, Moore and Mayor Dukes. Nay: none. Absent: none. Motion carried.
7. **Discussion and consideration of approving and entering into a contract with ADG P.C. for program and project management services associated with the Moving Midwest City Forward 2018 Bond projects, in the amount of \$472,364.00.** After discussion, Allen made a motion to enter into and approve the Contract, as submitted, seconded by Reed. Voting aye: Eads, Byrne, Bowen, Reed, Allen, Moore and Mayor Dukes. Nay: none. Absent: none. Motion carried.

8. **Discussion and consideration of approving and entering into a contract with Smith, Roberts, Baldischwiler, L.L.C. (S.R.B.) for construction administration and inspection services associated with the Moving Midwest City Forward 2018 Bond Proposition I, Street Rehabilitation, in the amount of \$205,200.00.** After discussion, Eads made a motion to enter into and approve the Contract, as submitted, seconded by Allen. Voting aye: Eads, Byrne, Bowen, Reed, Allen, Moore and Mayor Dukes. Nay: none. Absent: none. Motion carried.
9. **Discussion and consideration of approving an ordinance adding Chapter 36.5, Small Wireless Facilities to the Midwest City Municipal Code; adding the following sections in the new chapter: Section 36.5-1, Statement of Purpose; Section 36.5-2, Definitions; Section 36.5-3, Small Wireless Facility Permitting Regulations; Section 36.5-4, Requirements and Conditions; Section 36.5-5, Abandonment; Section 36.5-6, Indemnification; Section 36.5-7, Insurance and Bonds; and Providing for Repealer and Severability; and Declaring and Emergency.** After discussion, Byrne made a motion to approve Ordinance 3369, as submitted, seconded by Eads. Voting aye: Eads, Byrne, Bowen, Reed, Allen, Moore and Mayor Dukes. Nay: none. Absent: none. Motion carried.

Eads then made a motion to approve the emergency clause, as submitted, seconded by Byrne. Voting aye: Eads, Byrne, Bowen, Reed, Allen, Moore and Mayor Dukes. Nay: none. Absent: none. Motion carried.
10. **Discussion and consideration of appointing a replacement for Travis Jernigan to the Plumbing, Gas, and Mechanical Board. (Continued from April 9, 2019 Council meeting).** No action was taken.
11. **Discussion and Consideration of the appointment of Tim Lyon as City Manager effective June 13, 2019, and acceptance of the terms of the proposed employment contract between the City of Midwest City and Tim Lyon.** After Staff and Council spoke, Eads made a motion to appoint Tim Lyon as the new City Manager, as submitted, seconded by Allen. Voting aye: Eads, Byrne, Bowen, Reed, Allen, Moore and Mayor Dukes. Nay: none. Absent: none. Motion carried.

NEW BUSINESS/PUBLIC DISCUSSION.

Dana Brockway, 2001 N. Martin Luther King; Ron Green, 4521 N.E. 19th Circle; and Bill Bridges, 10300 Belmont Ave. spoke to Council.

FURTHER INFORMATION.

1. Minutes of the April 2, 2019 Planning Commission meeting.

ADJOURNMENT.

There being no further business, Mayor Dukes adjourned the meeting at 7:00 PM.

ATTEST:

MATT DUKES, Mayor

SARA HANCOCK, City Clerk



FINANCE DEPARTMENT
100 N. MIDWEST BOULEVARD
MIDWEST CITY, OK 73110
CBARRON@MIDWESTCITY.ORG
OFFICE: 405-739-1245
WWW.MIDWESTCITYOK.ORG

TO: Honorable Mayor and City Council

FROM: Christy Barron, City Treasurer/Finance Director

DATE: May 14, 2019

SUBJECT: Discussion and consideration of supplemental budget adjustments to the following funds for FY 2018-2019, increase: General Fund, expenses/Transfers Out (00) \$804,267. Police Fund, revenue/Transfers In (00) \$320,286. Fire Fund, revenue/Transfers In (00) \$259,010. General Fund, expenses/Transfers Out (00) \$2,520. CDBG Fund, revenue/Transfers In (00) \$2,520. General Fund, expenses/Street (09) \$58,547. Hotel/Motel Fund, expenses/Transfers Out (87) \$4,369. Park and Rec Fund, revenue/Transfers In (00) \$611. CVB Fund, revenue/Transfers In (00) \$2,447. Welcome Center Fund, revenue/Transfers In (00) \$1,311. Customer Deposits Fund, revenue/Investment Interest (00) \$5,278; expenses/Transfers Out (00) \$5,278. Municipal Court Fund, revenue/Investment Interest (00) \$225; expenses/Transfers Out (00) \$225. General Fund, revenue/Transfers In (00) \$225. L&H Fund, expenses/Personnel (03) \$377,018. General Fund, revenue/Transfers In (00) \$224,971. Sales Tax Capital Improvement Fund, expenses/Transfers Out (00) \$227,366. Capital Improvements Fund, revenue/Transfers In (00) \$91,963. Sooner Rose TIF Fund, expenses/None (00) \$1,221; expenses/Hospital Authority (90) \$65,000. General Gov't Sales Tax Fund, expenses/City Manager (01) \$750. Fire Fund, expenses/Fire (64) \$270,580. Grants Fund, revenue/Intergovernmental (88) \$75,619; expenses/Transfers Out (88) \$75,619. Disaster Relief Fund, revenue/Transfers In (88) \$75,619. Capital Improvements Fund, expenses/Capital Improvements (57) \$8,000. Fire Fund, expenses/Fire (64) \$36,000. 2018 Election G.O. Bonds Fund, expenses/Fire (64) \$1,272; expenses/Emergency Operations (21) \$26,198. Decrease: 2018 Election G.O. Bonds Fund, expenses/Park & Rec (06) \$94,104; expenses/General Government (14) \$26,703; expenses/29th Street (92) \$60,910; expenses/Animal Control (10) \$3,142.

The first through third supplements are needed to increase transfers out of General Fund into Police and Fire Funds due to increase in sales tax revenue for fiscal year over original estimate. The fourth and fifth supplements are needed to increase transfer out of General Fund into CDBG Fund to cover non-grant expenses in CDBG Fund over original estimated amount. The sixth supplement is needed to meet utilities/communications expenses in Street Department to end of fiscal year. The seventh through tenth supplements are needed to increase transfers out of Hotel/Motel Fund into Park & Rec, CVB and Welcome Center Funds due to hotel/motel tax revenues exceeding original estimate for fiscal year. The eleventh supplement is needed to increase budget for interest revenue and transfer out of Customer Deposits Fund into Water Fund. The twelfth and thirteenth supplements are needed to increase budget for interest revenue and transfer out of Municipal Court Fund into General Fund due to interest on court bond

deposits exceeding original fiscal year estimate. The fourteenth supplement is needed to increase budget for health claims expense due to actual claims exceeding original estimate for fiscal year. The fifteenth supplement is needed to increase transfer into General Fund from Capital Improvement Revenue Bond Fund due to sales tax revenue for fiscal year exceeding original estimate. The sixteenth supplement is needed to increase transfer out of Sales Tax Capital Improvements Fund into Capital Improvements Revenue Bond Fund and Capital Improvements Fund due to increase in sales tax revenue for fiscal year over original estimate. The seventeenth supplement is needed to increase transfer in from Sales Tax Capital Improvements Fund into Capital Improvements Fund due to increase in sales tax revenue for fiscal year over original estimate. The eighteenth supplement is needed to budget principal and issuance costs related to TIF 2018 bond. The nineteenth supplement is needed to budget employee 40-year service award. The twentieth supplement is needed to increase budget due to IAFF Collective Bargaining Agreement approved by Council February 12, 2019. The twenty-first and twenty-second supplements are needed to budget reimbursement from OK Dept of Emergency Management for December 2015 ice storm expenses and transfer out of Grants Fund into Disaster Relief Fund. The twenty-third supplement is needed to increase budget for N. Oaks Cul De Sac Phase 4 Project. The twenty-fourth supplement is needed to budget G.O. bond project management fees to be reimbursed by future G.O. bond proceeds. The decrease is needed to adjust G.O. bond project budgets due to revision of project management fee contract.

Christy Barron

Christy Barron
Finance Director

SUPPLEMENTS

May 14, 2019

Fund GENERAL (010)		BUDGET AMENDMENT FORM Fiscal Year 2018-2019			
		Estimated Revenue		Budget Appropriations	
<u>Dept Number</u>	<u>Department Name</u>	<u>Increase</u>	<u>Decrease</u>	<u>Increase</u>	<u>Decrease</u>
00	Transfers Out			804,267	
		<u>0</u>	<u>0</u>	<u>804,267</u>	<u>0</u>

Explanation:
To increase budgeted transfers out due to increase in sales tax revenue for fiscal year 2018-2019 over original estimate. Funding to come from fund balance.

Fund POLICE (020)		BUDGET AMENDMENT FORM Fiscal Year 2018-2019			
		Estimated Revenue		Budget Appropriations	
<u>Dept Number</u>	<u>Department Name</u>	<u>Increase</u>	<u>Decrease</u>	<u>Increase</u>	<u>Decrease</u>
00	Transfers In	320,286			
		<u>320,286</u>	<u>0</u>	<u>0</u>	<u>0</u>

Explanation:
To increase budgeted transfers in from General Fund due to increase in sales tax revenue for fiscal year 2018-2019 over original estimate.

Fund FIRE (040)		BUDGET AMENDMENT FORM Fiscal Year 2018-2019			
		Estimated Revenue		Budget Appropriations	
<u>Dept Number</u>	<u>Department Name</u>	<u>Increase</u>	<u>Decrease</u>	<u>Increase</u>	<u>Decrease</u>
00	Transfers In	259,010			
		<u>259,010</u>	<u>0</u>	<u>0</u>	<u>0</u>

Explanation:
To increase budgeted transfers in from General Fund due to increase in sales tax revenue for fiscal year 2018-2019 over original estimate.

Fund GENERAL (010)		BUDGET AMENDMENT FORM Fiscal Year 2018-2019			
		Estimated Revenue		Budget Appropriations	
<u>Dept Number</u>	<u>Department Name</u>	<u>Increase</u>	<u>Decrease</u>	<u>Increase</u>	<u>Decrease</u>
00	Transfers Out			2,520	
		<u>0</u>	<u>0</u>	<u>2,520</u>	<u>0</u>

Explanation:
To increase transfer out to CDBG Fund to cover non-grant expenses over original estimated amount. Funding to come from fund balance.

SUPPLEMENTS
May 14, 2019

Fund CDBG (141)		BUDGET AMENDMENT FORM Fiscal Year 2018-2019			
<u>Dept Number</u>	<u>Department Name</u>	Estimated Revenue		Budget Appropriations	
		<u>Increase</u>	<u>Decrease</u>	<u>Increase</u>	<u>Decrease</u>
00	Transfers In	2,520			
		<u>2,520</u>	<u>0</u>	<u>0</u>	<u>0</u>
Explanation: To increase transfer in from General Fund to cover non-grant expenses over original estimated amount.					

Fund GENERAL (010)		BUDGET AMENDMENT FORM Fiscal Year 2018-2019			
<u>Dept Number</u>	<u>Department Name</u>	Estimated Revenue		Budget Appropriations	
		<u>Increase</u>	<u>Decrease</u>	<u>Increase</u>	<u>Decrease</u>
09	Street			58,547	
		<u>0</u>	<u>0</u>	<u>58,547</u>	<u>0</u>
Explanation: To increase budget to cover utilities/communications expenses to end of fiscal year. Funding to come from fund balance.					

Fund HOTEL/MOTEL (225)		BUDGET AMENDMENT FORM Fiscal Year 2018-2019			
<u>Dept Number</u>	<u>Department Name</u>	Estimated Revenue		Budget Appropriations	
		<u>Increase</u>	<u>Decrease</u>	<u>Increase</u>	<u>Decrease</u>
87	Transfers Out			4,369	
		<u>0</u>	<u>0</u>	<u>4,369</u>	<u>0</u>
Explanation: To increase budgeted transfers out due to hotel/motel tax revenues exceeding original estimate for fiscal year. Funding to come from fund balance.					

Fund PARK & RECREATION (123)		BUDGET AMENDMENT FORM Fiscal Year 2018-2019			
<u>Dept Number</u>	<u>Department Name</u>	Estimated Revenue		Budget Appropriations	
		<u>Increase</u>	<u>Decrease</u>	<u>Increase</u>	<u>Decrease</u>
00	Transfers In	611			
		<u>611</u>	<u>0</u>	<u>0</u>	<u>0</u>
Explanation: To increase transfer in from Hotel/Motel Fund due to hotel/motel tax revenues exceeding original estimate for fiscal year.					

SUPPLEMENTS

May 14, 2019

Fund CVB (046)		BUDGET AMENDMENT FORM Fiscal Year 2018-2019			
		Estimated Revenue		Budget Appropriations	
<u>Dept Number</u>	<u>Department Name</u>	<u>Increase</u>	<u>Decrease</u>	<u>Increase</u>	<u>Decrease</u>
00	Transfers In	2,447			
		2,447	0	0	0
Explanation: To increase transfer in from Hotel/Motel Fund due to hotel/motel tax revenues exceeding original estimate for fiscal year.					

Fund WELCOME CENTER (045)		BUDGET AMENDMENT FORM Fiscal Year 2018-2019			
		Estimated Revenue		Budget Appropriations	
<u>Dept Number</u>	<u>Department Name</u>	<u>Increase</u>	<u>Decrease</u>	<u>Increase</u>	<u>Decrease</u>
00	Transfers In	1,311			
		1,311	0	0	0
Explanation: To increase transfer in from Hotel/Motel Fund due to hotel/motel tax revenues exceeding original estimate for fiscal year.					

Fund CUSTOMER DEPOSITS (230)		BUDGET AMENDMENT FORM Fiscal Year 2018-2019			
		Estimated Revenue		Budget Appropriations	
<u>Dept Number</u>	<u>Department Name</u>	<u>Increase</u>	<u>Decrease</u>	<u>Increase</u>	<u>Decrease</u>
00	Investment Interest	5,278			
00	Transfers Out			5,278	
		5,278	0	5,278	0
Explanation: To increase budget for interest revenue and transfer out to Water Fund due to interest on customer utility deposits exceeding original fiscal year estimate.					

Fund MUNICIPAL COURT (235)		BUDGET AMENDMENT FORM Fiscal Year 2018-2019			
		Estimated Revenue		Budget Appropriations	
<u>Dept Number</u>	<u>Department Name</u>	<u>Increase</u>	<u>Decrease</u>	<u>Increase</u>	<u>Decrease</u>
00	Investment Interest	225			
00	Transfers Out			225	
		225	0	225	0
Explanation: To increase budget for interest revenue and transfer out to General Fund due to interest on court bond deposits exceeding original fiscal year estimate.					

SUPPLEMENTS

May 14, 2019

Fund GENERAL (010)		BUDGET AMENDMENT FORM Fiscal Year 2018-2019			
		Estimated Revenue		Budget Appropriations	
<u>Dept Number</u>	<u>Department Name</u>	<u>Increase</u>	<u>Decrease</u>	<u>Increase</u>	<u>Decrease</u>
00	Transfers In	225			
		<u>225</u>	<u>0</u>	<u>0</u>	<u>0</u>

Explanation:
To increase transfers in from Municipal Court Fund due to interest on court bond deposits exceeding original fiscal year estimate.

Fund L&H (240)		BUDGET AMENDMENT FORM Fiscal Year 2018-2019			
		Estimated Revenue		Budget Appropriations	
<u>Dept Number</u>	<u>Department Name</u>	<u>Increase</u>	<u>Decrease</u>	<u>Increase</u>	<u>Decrease</u>
03	Personnel			377,018	
		<u>0</u>	<u>0</u>	<u>377,018</u>	<u>0</u>

Explanation:
To increase budget for health claims due to actual claims exceeding original estimate for fiscal year. Funding to come from fund balance.

Fund GENERAL (010)		BUDGET AMENDMENT FORM Fiscal Year 2018-2019			
		Estimated Revenue		Budget Appropriations	
<u>Dept Number</u>	<u>Department Name</u>	<u>Increase</u>	<u>Decrease</u>	<u>Increase</u>	<u>Decrease</u>
00	Transfers In	224,971			
		<u>224,971</u>	<u>0</u>	<u>0</u>	<u>0</u>

Explanation:
To increase transfer in from Capital Improvement Revenue Bonds Fund due to sales tax revenue for fiscal year exceeding original estimate.

Fund SALES TAX CAPITAL IMPROVEMENTS (340)		BUDGET AMENDMENT FORM Fiscal Year 2018-2019			
		Estimated Revenue		Budget Appropriations	
<u>Dept Number</u>	<u>Department Name</u>	<u>Increase</u>	<u>Decrease</u>	<u>Increase</u>	<u>Decrease</u>
00	Transfers Out			227,366	
		<u>0</u>	<u>0</u>	<u>227,366</u>	<u>0</u>

Explanation:
To increase budgeted transfers out due to increase in sales tax revenue for fiscal year 2018-2019 over original estimate. Funding to come from fund balance.

SUPPLEMENTS

May 14, 2019

Fund CAPITAL IMPROVEMENTS (157)		BUDGET AMENDMENT FORM Fiscal Year 2018-2019			
		Estimated Revenue		Budget Appropriations	
<u>Dept Number</u>	<u>Department Name</u>	<u>Increase</u>	<u>Decrease</u>	<u>Increase</u>	<u>Decrease</u>
00	Transfers In	91,963			
		91,963	0	0	0
Explanation: To increase transfer in from Sales Tax Capital Improvements Fund due to sales tax revenue for fiscal year exceeding original estimate.					

Fund SOONER ROSE TIF (352)		BUDGET AMENDMENT FORM Fiscal Year 2018-2019			
		Estimated Revenue		Budget Appropriations	
<u>Dept Number</u>	<u>Department Name</u>	<u>Increase</u>	<u>Decrease</u>	<u>Increase</u>	<u>Decrease</u>
00				1,221	
90	Hospital Authority			65,000	
		0	0	66,221	0
Explanation: To budget principal and issuance costs related to TIF 2018 bond. Funding to come from fund balance.					

Fund GENERAL GOV'T SALES TAX (009)		BUDGET AMENDMENT FORM Fiscal Year 2018-2019			
		Estimated Revenue		Budget Appropriations	
<u>Dept Number</u>	<u>Department Name</u>	<u>Increase</u>	<u>Decrease</u>	<u>Increase</u>	<u>Decrease</u>
01	City Manager			750	
		0	0	750	0
Explanation: To budget employee 40-year service award. Funding to come from fund balance.					

Fund FIRE (040)		BUDGET AMENDMENT FORM Fiscal Year 2018-2019			
		Estimated Revenue		Budget Appropriations	
<u>Dept Number</u>	<u>Department Name</u>	<u>Increase</u>	<u>Decrease</u>	<u>Increase</u>	<u>Decrease</u>
64	Fire			270,580	
		0	0	270,580	0
Explanation: To increase budget due to IAFF Collective Bargaining Agreement approved by Council February 12,2019. Funding to come from fund balance.					

SUPPLEMENTS

May 14, 2019

Fund GRANTS (143)		BUDGET AMENDMENT FORM Fiscal Year 2018-2019			
		Estimated Revenue		Budget Appropriations	
<u>Dept Number</u>	<u>Department Name</u>	<u>Increase</u>	<u>Decrease</u>	<u>Increase</u>	<u>Decrease</u>
88	Intergovernmental	75,619			
88	Transfers Out			75,619	
		75,619	0	75,619	0
Explanation:					
To budget reimbursement from Oklahoma Department of Emergency Management for expenses related to December 2015 ice storm and transfer out to Disaster Relief Fund.					

Fund DISASTER RELIEF (310)		BUDGET AMENDMENT FORM Fiscal Year 2018-2019			
		Estimated Revenue		Budget Appropriations	
<u>Dept Number</u>	<u>Department Name</u>	<u>Increase</u>	<u>Decrease</u>	<u>Increase</u>	<u>Decrease</u>
88	Transfers In	75,619			
		75,619	0	0	0
Explanation:					
To budget transfer in of reimbursement from Oklahoma Department of Emergency Management for expenses related to December 2015 ice storm from Grants Fund.					

Fund CAPITAL IMPROVEMENTS (157)		BUDGET AMENDMENT FORM Fiscal Year 2018-2019			
		Estimated Revenue		Budget Appropriations	
<u>Dept Number</u>	<u>Department Name</u>	<u>Increase</u>	<u>Decrease</u>	<u>Increase</u>	<u>Decrease</u>
57	Capital Improvements			8,000	
		0	0	8,000	0
Explanation:					
To increase budget for N. Oaks Cul De Sac Phase 4 Project. Funding to come from fund balance.					

Fund FIRE (040)		BUDGET AMENDMENT FORM Fiscal Year 2018-2019			
		Estimated Revenue		Budget Appropriations	
<u>Dept Number</u>	<u>Department Name</u>	<u>Increase</u>	<u>Decrease</u>	<u>Increase</u>	<u>Decrease</u>
64	Fire			36,000	
		0	0	36,000	0
Explanation:					
To increase budget for GO Bond Project management fees to be reimbursed by future G.O. Bond proceeds. Funding to come from fund balance.					

DECREASE

Fund 2018 ELECTION G.O. BONDS (270)		BUDGET AMENDMENT FORM Fiscal Year 2018-2019			
		Estimated Revenue		Budget Appropriations	
<u>Dept Number</u>	<u>Department Name</u>	<u>Increase</u>	<u>Decrease</u>	<u>Increase</u>	<u>Decrease</u>
06	Park & Rec				94,104
14	General Gov't				26,703
92	29th Street				60,910
10	Animal Control				3,142
64	Fire			1,272	
21	Emergency Operations			26,198	
		<u>0</u>	<u>0</u>	<u>27,470</u>	<u>184,859</u>

Explanation:
To adjust GO Bond Project budgets due to revision of project management fee contract.



Finance Department
100 N. Midwest Boulevard
Midwest City, OK 73110
cbarron@midwestcity.org
Office: 405-739-1245
www.midwestcityok.org

TO: Honorable Mayor and City Council

FROM: Christy Barron, Finance Director

DATE: May 14, 2019

SUBJECT: Discussion and consideration of approving a resolution for the City Council of the City of Midwest City relating to the expenditure of approximately \$17,000 of the total police/fire joint training facility bond project and \$19,000 of the total fire station remodel bond project for the payment of professional program management services; indicating the official action of the City Council for the reimbursement to Midwest City Fire Department's 040 fund balance of such expenditure by the issuance of tax exempt general obligation bonds of the city of midwest city, previously authorized at an election held for that purpose on august 28, 2018 authorizing the payment of professional services.

On August 28, 2018, an election was held which authorized the issuance of tax exempt general obligation bonds for the City of Midwest City. One of the propositions approved included funding for a police/fire joint training facility and fire station remodel. In order to encumber the recently approved contract for program management services with ADG, it was necessary to use fire department budget because funding for these two projects isn't available until phase three of the GO bond.

This resolution allows the City Council to reimburse the fire department once the bonds funding these projects are issued.

Staff recommends approval and action is at the discretion of Council.

Christy Barron
Finance Director

A RESOLUTION FOR THE CITY COUNCIL OF THE CITY OF MIDWEST CITY RELATING TO THE EXPENDITURE OF APPROXIMATELY \$17,000 OF THE TOTAL POLICE/FIRE JOINT TRAINING FACILITY BOND PROJECT AND \$19,000 OF THE TOTAL FIRE STATION REMODEL BOND PROJECT FOR THE PAYMENT OF PROFESSIONAL PROGRAM MANAGEMENT SERVICES; INDICATING THE OFFICIAL ACTION OF THE CITY COUNCIL FOR THE REIMBURSEMENT TO MIDWEST CITY FIRE DEPARTMENT'S 040 FUND BALANCE OF SUCH EXPENDITURE BY THE ISSUANCE OF TAX EXEMPT GENERAL OBLIGATION BONDS OF THE CITY OF MIDWEST CITY, PREVIOUSLY AUTHORIZED AT AN ELECTION HELD FOR THAT PURPOSE ON AUGUST 28, 2018 AUTHORIZING THE PAYMENT OF PROFESSIONAL SERVICES.

WHEREAS, the City Council of the City of Midwest City, Oklahoma, approved Phase I, Phase II, and Phase III of the 2018 General Obligation Bond Proposal on the 9th day of October, 2018 in order to provide a source of funding for certain enumerated projects; and

WHEREAS, the voters of the City of Midwest City approved the 2018 Moving Forward Bond Issue at a Special Election called for that purpose held on August 28, 2018; and

WHEREAS, Phase I, Phase II, and Phase III of the 2018 Moving Forward Bond Issue provides for a number of projects including, among others, the Police/Fire Joint Training Facility, and Fire Station Remodel; and

WHEREAS, program management services are desirable for the successful implementation of these projects and include a variety of services including but not limited to facilities assessment, planning and programming, architectural and engineering plan review, design and construction coordination and construction observation services ("Program Management Services"); and

WHEREAS, City Staff initiated a Request for Proposals in November of 2018 to qualified firms including ADG P.C. to perform the Program Management Services; and

WHEREAS, the City Council has approved a contract with ADG P.C. ("Program Manager") to provide the necessary Program Management Services.

NOW, THEREFORE, BE IT RESOLVED by the City Council of the City of Midwest City:

1. The City Council of the City of Midwest City hereby declares its official intent to reimburse this expenditure by the issuance of tax exempt general obligation bonds of the City, previously authorized at an election held for that purpose on August 28, 2018 in an amount of \$17,000 for the police/fire joint training facility and \$19,000 for the fire station remodel to the Midwest City Fire Department's 040 fund balance, and

2. That this resolution shall take effect and be in full force from and after its passage as provided by law.

PASSED and APPROVED by the City of Midwest City this 14th day of May, 2019.

CITY OF MIDWEST CITY, OKLAHOMA

ATTEST:

MATTHEW D. DUKES II, Mayor

SARA HANCOCK, City Clerk

APPROVED as to form and legality this _____ day of _____, 2019.

HEATHER POOLE, City Attorney



Human Resources
100 N. Midwest Boulevard
Midwest City, OK 73110
office 405.739.1235

Memorandum

TO: Honorable Mayor and Council

FROM: Catherine Wilson, Human Resources Director

DATE: May 14, 2019

RE: Discussion and consideration of accepting the monthly report on the City of Midwest City Employees' Health Benefits Plan by the City Manager and action as deemed necessary by the Council to maintain the plan.

This item is placed on the agenda at the request of the Council. Attached to this memo is information regarding the current financial condition of the City Employees' Health Benefits Plan for the month of March 2019 which is the ninth (9) period of the FY 2018/2019.

This is a staff update

A handwritten signature in black ink, appearing to read "Catherine Wilson", with a long horizontal flourish extending to the right.

Catherine Wilson, Human Resources Director

FISCAL YEAR 2018-2019	Jul -18	Aug -18	Sep -18	Oct -18	Nov -18	Dec -18	Jan -19	Feb -19	Mar -19	Apr -19	May -19	Jun -19
PLAN INCOME												
Budgeted (MTD)	590,806	886,209	590,806	590,806	590,806	590,806	590,806	590,806	886,209	590,806	590,806	590,806
Actual (MTD)	580,003	778,717	869,305	675,077	605,701	604,448	596,882	575,414	821,358			
Budgeted (YTD)	590,806	1,477,015	2,067,821	2,658,627	3,249,433	3,840,239	4,431,045	5,021,851	5,908,060			
Actual (YTD)	580,003	1,358,720	2,228,025	2,903,102	3,508,803	4,113,251	4,710,133	5,285,547	6,106,905			
PLAN CLAIMS/ADMIN COSTS	Jul -18	Aug -18	Sep -18	Oct -18	Nov -18	Dec -18	Jan -19	Feb -19	Mar -19	Apr -19	May -19	Jun -19
Budgeted (MTD)	569,824	854,736	569,824	569,824	569,824	569,824	569,824	569,824	854,736	569,824	569,824	569,824
Actual (MTD)	697,154	533,729	955,290	867,993	682,361	587,394	736,335	389,324	755,224			
Budgeted (YTD)	569,824	1,424,560	1,994,384	2,564,208	3,134,032	3,703,856	4,273,680	4,843,504	5,698,240			
Actual (YTD)	697,154	1,230,883	2,186,173	3,054,166	3,736,527	4,323,921	5,060,256	5,449,580	6,204,804			
EXCESS INCOME vs. EXPENDITURES	Jul -18	Aug -18	Sep -18	Oct -18	Nov -18	Dec -18	Jan -19	Feb -19	Mar -19	Apr -19	May -19	Jun -19
Budgeted (MTD)	20,982	31,473	20,982	20,982	20,982	20,982	20,982	20,982	31,473	20,982	20,982	20,982
Actual (MTD)	-117,151	244,988	-85,985	-192,916	-76,660	17,054	-139,453	186,090	66,134			
Budgeted (YTD)	20,982	52,455	73,437	94,419	115,401	136,383	157,365	178,347	209,820			
Actual (YTD)	-117,151	127,837	41,852	-151,064	-227,724	-210,670	-350,123	-164,033	-97,899			
FISCAL YEAR 2017-2018	**Jul -17**	Aug -17	Sep -17**	**Oct -17**	Nov -17	Dec -17	**Jan -18**	Feb -18	Mar -18**	Apr -18	**May -18**	Jun -18
PLAN INCOME												
Budgeted (MTD)	583,812	583,812	875,718	583,812	583,812	583,812	583,812	583,812	875,718	583,812	583,812	583,812
Actual (MTD)	549,884	581,809	762,314	573,509	575,591	584,948	639,389	575,734	780,330	582,690	593,056	585,557
Budgeted (YTD)	583,812	1,167,624	2,043,342	2,627,154	3,210,966	3,794,778	4,378,590	4,962,402	5,838,120	6,421,932	7,005,744	7,589,556
Actual (YTD)	549,884	1,131,693	1,894,007	2,467,516	3,043,107	3,628,055	4,267,444	4,843,178	5,623,508	6,206,198	6,799,254	7,384,811
PLAN CLAIMS/ADMIN COSTS	**Jul -17**	Aug -17	Sep -17	**Oct -17**	Nov -17	Dec -17	**Jan -18**	Feb -18	Mar -18	Apr -18	**May -18**	Jun -18
Budgeted (MTD)	583,489	583,489	875,235	583,489	583,489	583,489	583,489	583,489	875,235	583,489	583,489	583,489
Actual (MTD)	570,148	531,432	564,791	564,182	535,313	709,157	594,992	427,810	594,358	566,711	655,998	551,006
Budgeted (YTD)	583,489	1,166,978	1,731,769	2,295,951	2,831,264	3,540,421	4,135,413	4,563,223	5,157,581	5,724,292	6,380,290	6,931,296
Actual (YTD)	570,148	1,101,580	1,666,371	2,230,553	2,765,866	3,475,023	4,070,015	4,497,825	5,092,183	5,658,894	6,314,892	6,865,898
EXCESS INCOME vs. EXPENDITURES	**Jul -17**	Aug -17	Sep -17	**Oct -17**	Nov -17	Dec -17	**Jan -18**	Feb -18	Mar -18	Apr -18	**May -18**	Jun -18
Budgeted (MTD)	323	323	483	323	323	323	323	323	483	323	323	323
Actual (MTD)	-20,264	50,377	197,523	9,327	40,278	-124,209	44,397	147,924	185,972	15,979	-62,942	34,551
Budgeted (YTD)	323	646	311,573	331,203	379,702	254,357	243,177	399,179	680,539	697,640	625,454	658,260
Actual (YTD)	-20,264	30,113	227,636	236,963	277,241	153,032	197,429	345,353	531,325	547,304	484,362	518,913

March 9/FY 2019: \$2,107,877
 March 9/FY 2018: \$2,228,083
 March 9/FY 2017: \$1,793,608
 March 9/FY 2016: \$1,512,163

AUGUST AND MARCH HAVE 3 PAYROLLS

**** HAD FIVE MONDAYS WITH REPORTED MEDICAL CLAIMS PAID****



Human Resources
100 N. Midwest Boulevard
Midwest City, OK 73110
office 405.739.1235

Memorandum

DATE: May 14, 2019
TO: Honorable Mayor and Council
FROM: Catherine Wilson, Human Resources Director

RE: Discussion and consideration of renewing the Consulting Agreement with Gallagher Benefit Services Inc. in the amount of \$55,560 to include the coordination and management of benefit services, serving as the liaison with PlanSource to provide an electronic platform for streamlining benefit enrollments and information, and for the coordination and management of the Section 125 Flexible Spending Plan (Cafeteria Plan) with Discovery Benefits for the 2019-20 fiscal year.

This agreement will ensure that GBS will continue to provide on an as-needed basis services and will now include the new services effective July 1, 2019 in the following areas as they pertain to the Employee Health and Life Benefits Plan(s):

- The coordination and management of benefit services serving as the liaison between Midwest City and PlanSource to provide an electronic platform for streamlining benefit enrollments and information
- The coordination and management of the Section 125 Flexible Spending Plan (Cafeteria Plan) on behalf of Midwest City
- Renewal Analysis
- Periodic Plan Financial Reports (for budget preparation and planning)
- End of year Financial Reports
- Benefit Plan Design and/or Redesign
- Legislative and Corporate Compliance Support
- Carrier Marketing and Negotiations as directed by the City
- Assistance in Developing a HIPPA Compliant Wellness Program
- Employee Education Programs
- Communication Materials for all Benefits
- Benefit Administration Assessment
- Market and Benchmark Studies
- Other services are available upon mutual agreement of the parties

We feel that the consulting services provided to date have been beneficial to the Employee Health Plan. Thus far; Gallagher has been assisting in updating the Health Plan Document to make sure that it is compliant with all federal and state guidelines. Gallagher has been assisting with the development of the Wellness Plan document and implementation of the Wellness Plan. Gallagher



Human Resources
100 N. Midwest Boulevard
Midwest City, OK 73110
office 405.739.1235

was helpful in analyzing the renewals and in recommending actuarial correct funding levels for the plan.

Staff feels that investigating the possibility of providing additional options to our employees is important. GBS will assist us in investigating these options, and in designing or redesigning the plan to accommodate changes that will help to lower cost for both the employees and the City.

Staff recommends approval of the amendment of the agreement.

A handwritten signature in black ink, appearing to read "Catherine Wilson", with a long horizontal line extending from the end of the signature.

Catherine Wilson, Human Resources Director

CONSULTING AGREEMENT

This Consulting Agreement (this "Agreement") is made by and between Gallagher Benefit Services, Inc., ("Gallagher") and City of Midwest City (the "Client").

The Client wishes to enter into a consulting relationship with Gallagher on the terms and conditions set forth in this Agreement, and Gallagher is willing to accept such a consulting relationship. In consideration of and in reliance upon the terms and conditions contained in this Agreement, the Client and Gallagher agree as follows:

1. Engagement of Services

The Client engages Gallagher as a professional consultant to provide the consulting and/or brokerage services as more fully described in Exhibit A attached to this Agreement and incorporated herein. During the time that Gallagher is performing services for the Client under this Agreement, and for all purposes outlined in this document, Gallagher's status will be that of an independent contractor of the Client.

2. Term and Termination

The Effective Date of this Agreement is July 1, 2019. The term of Gallagher's engagement under this Agreement (the "Consulting Period") will begin as of the Effective Date and will remain in effect for one (1) year from the Effective Date. . Either party may terminate this Agreement by giving the other party at least thirty (30) days written notice of its intent to terminate. In the event such termination is effective during the Consulting Period (including any renewed Consulting Period), Client shall be responsible for compensating Gallagher for any services performed prior to the date of termination and Gallagher shall be responsible to Client to continue to provide services until the date of termination of this Agreement.

3. Compensation

As compensation for its services under this Agreement, Gallagher will receive carrier commissions and/or direct fee owed by the Client, as set forth in the Compensation Disclosure Statement attached hereto as Exhibit B. Additional information regarding Gallagher compensation can also be found in Exhibit B. Gallagher shall disclose the amount of commissions payable to it by each insurance company at the time it presents rates to Client. The Client is responsible for payment of Gallagher's fees (if applicable) within thirty (30) days of invoice receipt. If any amount is not paid in full when due without a good faith basis to withhold, that nonpayment will constitute a material breach of this Agreement that will allow Gallagher to immediately terminate this Agreement.

4. Performance and Scope

(a) Representations and Warranties. Each party represents, warrants and covenants to the other that: (i) it has full power and authority to make, execute, deliver and perform its obligations under this Agreement; (ii) the performance of its obligations pursuant to this Agreement shall be in accordance with all applicable laws; (iii) this Agreement has been duly executed and delivered by an authorized representative of such party and constitutes the legal, valid and binding obligation of such party, enforceable against such party in accordance with its terms; and (iv) there are no other agreements presently in force which would encumber or prevent either party's compliance with any terms of this Agreement.

(b) Standard of Care. Gallagher will perform its duties, responsibilities and obligations with the care, skill, prudence and diligence that a prudent employee benefits consultant or insurance broker acting in a like capacity and familiar with such matters would use in the conduct of an enterprise of a like

character and with like aims under the circumstances then prevailing. As appropriate, Gallagher will coordinate fiduciary review services and other related duties with the plan's claims administrator and/or insurance carrier(s). However, Gallagher generally does not accept any fiduciary duties or obligations with respect to a plan given that these are typically performed by the plan's claims administrator or insurance carriers.

(c) Reliance. In the performance of its duties, Gallagher may rely upon, and will have no obligation to independently verify the accuracy, completeness, or authenticity of, any written instructions or information provided to Gallagher by the Client or its designated representatives and reasonably believed by Gallagher to be genuine and authorized by the Client.

(d) No Practice of Law. Gallagher will not be obligated to perform, and the Client will not request performance of, any services which may constitute the unauthorized practice of law. The Client will be solely responsible for obtaining any legal advice, review or opinion as may be necessary to ensure that its own conduct and operations, including the engagement of Gallagher under the scope and terms herein, conform in all respects with applicable State and Federal laws and regulations and, to the extent that the Client has foreign operations, any applicable foreign laws and regulations.

(e) Subcontractors. Gallagher may cause another person or entity, as a subcontractor of Gallagher, to provide some of the services required to be performed by Gallagher hereunder; provided that Gallagher shall remain responsible for all acts and omissions of any such subcontractors (each of which shall be bound by Gallagher's obligations under this Agreement). Gallagher shall seek prior written approval from Client for any subcontractors providing substantive consulting, professional or managerial services. Prior written approval shall not be required for clerical, office, secretarial, IT back-up, administrative or similar support services.

(f) Conflict of Interest. Gallagher's engagement under this Agreement will not prevent it from taking similar engagements with other clients who may be competitors of the Client. Gallagher will, nevertheless, exercise care and diligence to prevent any actions or conditions which could result in a conflict with Client's best interest.

(g) Acknowledgements. In connection with Gallagher's services under this Agreement, Client agrees that:

(i) Although Gallagher will apply its professional judgment to access those insurance companies it believes are best suited to insure the Client's risks, there can be no assurance that the insurance companies Gallagher has accessed are the only or are the best suited ones to insure the Client's risks. The final decision to choose any insurance company has been made by the Client in its sole and absolute discretion. The Client understands and agrees that Gallagher does not take risk, and that Gallagher does not guarantee the financial solvency or security of any insurance company.

(ii) Any compensation of the types described above and disclosed to it does not constitute a conflict of interest and the Client expressly waives any claims alleging any such conflict of interest.

(iii) The compensation payable to Gallagher is solely for the services set forth under this Agreement, as detailed in Exhibit A. Any additional administrative, claims representative or other services (collectively, "Additional Services") will be governed by the terms of a separate agreement covering the Additional Services.

5. *Confidentiality*

(a) Client Information. Gallagher recognizes that certain confidential information may be furnished by the Client to Gallagher in connection with its services pursuant to this Agreement (“Confidential Information”). Gallagher agrees that it will disclose Confidential Information only to those who, in Gallagher’s reasonable determination, have a need to know such information. Confidential Information will not include information that (i) is in the possession of Gallagher prior to its receipt of such information from the Client, (ii) is or becomes publicly available other than as a result of a breach of this Agreement by Gallagher, or (iii) is or can be independently acquired or developed by Gallagher without violating any of its obligations under this Agreement. However, disclosure by Gallagher of any Confidential Information pursuant to the terms of a valid and effective subpoena or order issued by a court of competent jurisdiction, judicial or administrative agency or by a legislative body or committee will not constitute a violation of this Agreement. Unless prohibited by law, Gallagher shall provide Client with any such subpoena or order and an opportunity to object prior to disclosure. Furthermore, Gallagher will limit disclosure to that information required to be disclosed under the terms of the subpoena or order and will reasonably cooperate with Client (at Client’s expense) to limit such disclosure.

(b) HIPAA Privacy. Gallagher and the Client will each comply with any prohibitions, restrictions, limitations, conditions, or other requirements to the extent they apply to them directly or indirectly pursuant to the Health Insurance Portability and Accountability Act of 1996 (“HIPAA”) and its implementing regulation concerning privacy of individually identifiable health information as set forth in 45 CFR Parts 160-164, as amended from time to time. When required, the Client, as a representative of the health plans and Gallagher will enter into a separate Business Associate Agreement.

(c) Use of Names; Public Announcements. No party will use, in any commercial manner, the names, logos, trademarks or other intellectual property of the other party without its prior written consent. Except as may be required by law, no party will issue any press releases or make any public announcements of any kind regarding the relationship between the parties without the other party’s prior consent.

(d) Aggregated Data. Gallagher shall own any non-identifying, aggregated and statistical data that might be derived from providing services to Client (the “Aggregated Data”). Nothing herein shall be construed as prohibiting Gallagher from utilizing the Aggregated Data for purposes of operating Gallagher’s business. Gallagher shall not: (i) disclose to any third party any Aggregated Data that reveals Client’s identity or its Confidential Information; or (ii) reveal the identity, whether directly or indirectly, of any individual whose specific data might be used by Gallagher on behalf of Client.

6. *Indemnification Rights and Limitation of Liability*

Gallagher will promptly defend, indemnify and hold the Client harmless from and against any and all third-party claims, suits, actions, liabilities, losses, expenses or damages which the Client may incur as a result of any violation by Gallagher of any law, or any loss or expense to the Client caused by the negligent act or omission of Gallagher or any breach of this Agreement. However, notwithstanding any other term or provision of this Agreement, Gallagher shall not be liable to the Client for any exemplary, special, indirect, incidental, consequential or punitive damages (including but not limited to lost profits) which may result from Gallagher’s action or its failure to perform any term or condition of this Agreement, whether such liability is based upon tort, strict liability, breach of warranties, failure of essential purpose or otherwise and even if advised of the possibility of such damages. Furthermore, the aggregate liability under this Agreement, if any, of Gallagher to the Client for claimed losses or damages shall not exceed \$20,000,000.00. This provision applies to the fullest extent permitted by applicable law.

7. *Notices*

Any notices, requests or other communications pursuant to this Agreement will be addressed to the party at its address listed below. Such notices will be deemed to have been duly given, (i) if delivered in person or by courier, upon delivery; (ii) if sent by an overnight service with tracking capabilities, upon receipt; (iii) if sent by registered or certified mail, postage prepaid, within five (5) days of deposit in the mail; or (iv) if sent by fax or electronic mail, at such time as the party which sent the notice receives confirmation of receipt by the applicable method of transmittal.

If to the Client: City of Midwest City
Attention: Catherine Wilson
100 N. Midwest Blvd.
Midwest City, OK 73110

If to Gallagher: Gallagher Benefit Services, Inc.
Attention: Steve Stoll
615 E. Britton Road
Oklahoma City, OK 73114

Either party may, by written notice to the other, change the address to which notices to such party are to be delivered or mailed.

8. *Miscellaneous*

(a) Severability. The various provisions and subprovisions of this Agreement are severable and if any provision or subprovision or part thereof is held to be unenforceable by any court of competent jurisdiction, then such enforceability will not affect the validity or enforceability of the remaining provisions or subprovisions or parts thereof in this Agreement.

(b) Entire Agreement; Amendment. This Agreement, including all exhibits hereto, constitutes the entire agreement between the parties and supersedes all prior agreements and understandings, whether oral or written, between the parties regarding the subject matter hereof. Except for changes in carriers and/or lines of coverage noted in Exhibit B, which may occur upon unilateral approval of the Client, this Agreement may be modified or amended only by a written instrument executed by both parties. This Agreement may be executed by the parties in several counterparts, each of which shall be deemed to be an original copy.

(c) Waiver. No covenant, term or condition or the breach thereof will be deemed waived, except by written consent of the party against whom the waiver is claimed. Any waiver by either party hereto of any provision of this Agreement shall not be construed as a waiver of any other provision of this Agreement, nor shall such waiver be construed as a waiver of such provision with respect to any other event or circumstance, whether past, present or future.

(d) Governing Law; Rule of Construction. This Agreement will be construed, interpreted and enforced in accordance with the laws of the State of Oklahoma without giving effect to the choice of law principles thereof or any canon, custom or rule of law requiring construction against the drafter.

(e) Successors. This Agreement shall be binding upon and shall inure to the benefit of all assigns, transferees and successors in the interest of the parties hereto.

(f) Survival of Provisions. Sections 5 and 6 will survive the termination of this Agreement.

**[The remainder of this page intentionally left blank.
The parties' signatures appear on the following page.]**

IN WITNESS WHEREOF, the parties hereto have caused this Consulting Agreement to be duly executed on the date first written above.

City of Midwest City

By: _____
Name: _____
Title: _____
Date: _____

GALLAGHER BENEFIT SERVICES, INC.

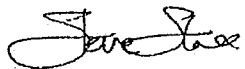
By:  _____
Name: Steve Stoll
Title: Area President
Date: 4.29.2019

ATTEST:

Sara Hancock, CITY CLERK

APPROVED as to form and legality this 14th day of May, 2019.

Heather Poole, CITY ATTORNEY

EXHIBITA SCOPE OF SERVICES

Subject to any changes and additions as may be mutually agreed by the parties in writing, availability and delivery of data from the insurance carrier and other third party vendors, Gallagher will provide the following Services to Client on an “as needed” basis:

RENEWAL ANALYSIS:

- Review and evaluate carrier projections
- Prepare “shadow” renewal projection
- Create financial modeling reports using proprietary Apex software
- Coordinate carrier negotiations
- Create employee contribution modeling reports
- Review identified benchmarks of projected plan costs
- Develop “working” rates for Client analysis and approval
- Assist with budget projections
- Provide renewal alternatives with cost impact of benefit plan changes

PERIODIC PLAN FINANCIAL REPORTS: (FREQUENCY TO BE MUTUALLY AGREED UPON)

- Summary of plan costs
- Analysis of actual vs. budget
- Employee contributions
- Large claims tracking
- Identification of costs for specific line of coverage
- Comparison of plan costs to aggregate stop-loss projections, if applicable
- Utilization review
- Comparison to prior claim period
- Plan trends

ANNUAL FINANCIAL REPORTS (END OF YEAR ACCOUNTING):

- Executive summary of program expenses
- Comparison of current costs to renewal costs
- Incurred But Not Reported (IBNR) claims analysis
- Overview of specific Stop-loss projections
- Future plan costs projections
- Dollars saved by contract negotiation
- Percent of benefit dollars paid by employee
- Claims by size
- Physician visit details
- Benefits paid by type of service
- Plan funding/budget comparison
- Fixed expense comparison

CARRIER MARKETING AND NEGOTIATIONS, AS DIRECTED BY CLIENT:

- Work with Client to develop a strategy to identify goals, analyze program costs and review both current and alternative funding arrangements
- Manage the renewal process with the current carrier to control costs
- Implement carrier renewal strategies with Client
- Develop timeline covering every aspect from RFP preparation to the delivery of employee communications
- Provide analysis of employee disruption report and preparation of geo-access report
- Provide analysis of discounts offered by various carriers by using CPT codes and carrier pricing data

- Manage RFP development that tailors the RFP to the desires, needs and financial directions provided by Client
- Explore alternative funding solutions
- Evaluate vendor responses to track variations in coverage and costs as they are identified
- Conduct finalist interviews to investigate and document intangibles such as personalities, service orientation and responsiveness
- Draft renewal analysis report, based on renewal negotiation, covers program and claims cost projections as well as complete information on benefit designs
- Facilitate decision process by coordinating close collaboration and discussions among the Gallagher team and Client

LEGISLATIVE AND CORPORATE COMPLIANCE SUPPORT:

- Provide legislative updates, including Technical Bulletins and Directions newsletters
- Evaluate plan design to assist with compliance with state and federal regulations
- Review benefit plan documents, including summary plan descriptions, contracts, employee summaries, and policies/procedures
- Conduct periodic seminars on regulatory issues
- Assist with the review and evaluation of COBRA and HIPAA compliance procedures
- Provide general information and guidance to assist with compliance with ERISA, FMLA, USERRA, Medicare Part D and other Federal legislation that directly affects the administration of plan benefits
- Provide template or sample compliance notices, certificates of creditable coverage and enrollment forms as reasonably requested by Client

DAY TO DAY ADMINISTRATIVE ASSISTANCE

EMPLOYEE EDUCATION PROGRAMS:

- Facilitate focus groups
- Monthly benefit communication directed to employees
- Educational meetings on coverage and trends

COMMUNICATION MATERIALS:

- Assist with the drafting and distribution of participant Satisfaction Surveys
- Assist with the drafting and distribution of Open Enrollment-New Member Orientation summary information and any other communications pertaining to the health and welfare program
- Provide annual open enrollment guidance and employee meeting materials
- Assist with marketing and oversight of Customized Enrollment Materials (if elected)
- Assist with participant wellness initiatives, as directed by Client

BENEFIT ADMINISTRATION ASSESSMENT:

- Periodic evaluation of internal plan enrollment and benefit termination processes
- Review, coordinate and implement Client agreed upon plan “best practices” to help limit plan liability and increase participant satisfaction
- Help identify opportunities for streamlining and improving administration procedures

MERGER AND ACQUISITION:

- Project claim liability and cost implications of active employee health & welfare benefits plan integration or consolidation, as requested by Client
- Provide coverage comparison analysis and recommendations as to plan design, carrier selections and funding mechanisms
- Provide disruption analysis reports
- Assist with employee meetings to introduce integrated program(s) or plan changes

MARKET BENCHMARKING STUDIES:

- Local Area Surveys
- Industry Surveys

BENEFIT PLAN DESIGN (OR REDESIGN):

- Help Client identify business and HR objectives that impact benefits
- Review with Client possible benefit strategies to meet their objectives
- Help Client evaluate/review current scope of benefits package – e.g., types & levels of coverage
- Work with Client to develop funding and contribution strategies
- Assist with budget projections for design alternatives

COORDINATE AND MANAGE SECTION 125 SERVICES:

- Gather information and assist Client with coordinating the Section 125 services provided by Discovery Benefits.
- Serve as a primary liaison between the Client and Discovery Benefits to help Client supervise Discovery Benefits services.
- Gallagher shall coordinate the payment of all uncontested and properly documented fees associated with Discovery Benefits as outlined in the contract between the Client and Discovery Benefits from fees received by Gallagher. (This duty terminated immediately upon termination of this Agreement.)
- Gallagher and the Client mutually agree that Gallagher shall not be liable for services provided by Discover Benefits.

BENEFITS ADVOCATE CENTER (BAC) CORE SERVICES:

- Maintain an employee customized and dedicated telephone number and email address for questions regarding benefits, provider find, plan costs and claim issues. Hours of Operation: Monday through Friday 7:00 AM to 6:00 PM CST
- Provide a dedicated team of individuals to support Client's plan participants and assist them with the following customer service issues:
 - Explain Client Benefits
 - Provider Find
 - Resolve ID Card Problems
 - Claim Resolution
 - Confirm Eligibility
 - Enrollment Questions
 - Navigating Claims Billing Issues
 - Advise on Claims Appeal Process

**EXHIBIT B
COMPENSATION DISCLOSURE STATEMENT**

Line of Coverage/Service	Insurance Company	Commission ¹ / Supplemental Compensation ²	Third Party Compensation	Direct Client Fees ³	Effective Date
Consulting Services	N/A	N/A ¹ / N/A ²	N/A	\$55,560.00 Per Year ³	7/1/2019
Medical Admin w/Stop Loss	BCBS of Oklahoma	N/A ¹ / \$1.00 to \$1.50 PEPM ²	N/A	N/A ³	7/1/2019
Dental	Sun Life	N/A ¹ / 0.5% to 2% ²	N/A	N/A ³	7/1/2019
Life / AD&D	Sun Life	15% ¹ / 0.5% to 2% ²	N/A	N/A ³	7/1/2019
Voluntary Life / AD&D	Sun Life	15% ¹ / 0.5% to 2% ²	N/A	N/A ³	7/1/2019
Voluntary Short Term Disability	Sun Life	15% ¹ / 0.5% to 2% ²	N/A	N/A ³	7/1/2019
Voluntary Long Term Disability	Sun Life	15% ¹ / 0.5% to 2% ²	N/A	N/A ³	7/1/2019
Long Term Disability	Sun Life	15% ¹ / 0.5% to 2% ²	N/A	N/A ³	7/1/2019
Accident	Sun Life	20% ¹ / 0.5% to 2% ²	N/A	N/A ³	7/1/2019
Critical Illness	Sun Life	17% ¹ / 0.5% to 2% ²	N/A	N/A ³	7/1/2019
Benefit Advocacy Center	NA – Gallagher	NA	NA	BAC core services included in commission – no additional fee.	7/1/2019
Section 125 Plan Document Services	Discovery Benefits	N/A	Sun Life provides payment to cover Discovery Benefits uncontested fees	N/A	7/1/2019

It should also be noted that:

- Gallagher is not an affiliate of the insurer or vendor whose contract is recommended. This means the insurer or vendor whose contract is recommended does not directly or indirectly have the power to exercise a controlling influence over the management or policies of Gallagher.
- Gallagher’s ability to recommend other insurance contracts or vendors is not limited by an agreement with any insurance carrier or vendor and Gallagher is effecting the transaction for applicable plan(s) in the ordinary course of Gallagher business. Thus, pertinent transaction(s) are at least as favorable to the applicable plan(s) as an arm’s length transaction with an unrelated party.
- Gallagher is not a trustee of the plan(s) and is neither the Plan Administrator of the plan(s), a Named Fiduciary of the plan(s), nor an employer which has employees in the plan(s).

For Employers and Plan Sponsors Subject to ERISA: This Disclosure Statement is being given to the Client (1) to make sure Client knows about Gallagher’s and Gallagher affiliates’ income before purchasing an insurance product and (2) for plans

¹ Commissions include all commissions/fees paid to Gallagher that are attributable to a contract or policy between a plan and an insurance company, or insurance service. This includes indirect fees that are paid to Gallagher paid by a third party, and includes, among other things, the payment of “finders’ fees” or other fees to Gallagher for a transaction or service involving the plan.

² Gallagher companies may receive supplemental compensation referred to in a variety of terms and definitions, such as contingent commissions, additional commissions and supplemental commissions.

³ Direct Fees include compensation to Gallagher paid for directly by the plan sponsor/Client.

subject to ERISA, to comply with the disclosure, acknowledgment and approval requirement of Prohibited Transaction Class Exemption No. 84-24⁴, which protects both Client and Gallagher⁵. Disclosure must be made to an independent plan fiduciary for the ERISA Plan(s), and Client acknowledges and confirms that this is a reasonable transaction in the best interest of participants in its ERISA Plan(s).

For more information on Gallagher's compensation arrangements, please visit www.ajg.com/compensation. In the event a client wishes to register a formal complaint regarding compensation Gallagher receives, please send an email to Compensation_Complaints@ajg.com.

⁴ Which allows an exemption from a prohibited transaction under Section 408(a) of the **Employee Retirement Income Security Act of 1974 (ERISA)**.

⁵ In making these disclosures, no position is taken, nor is one to be inferred, regarding the use of assets of a plan subject to ERISA to purchase such insurance.



Human Resources
100 N. Midwest Boulevard
Midwest City, OK 73110
office 405.739.1235

Memorandum

TO: Honorable Mayor and City Council

FROM: Catherine Wilson, Human Resources Director

DATE: May 14, 2019

SUBJECT: Discussion and consideration of renewing for the Fiscal Year 2019/2020 contracts with DB Compensation Software in the amount of \$2,000.04 to maintain the City's non-represented employees' compensation plan and job descriptions. There is no cost increase over last year.

Since all contracts expire at the end of each fiscal year, it is necessary to renew these contracts. This agreement provides data base maintenance and software support for the non-represented employees compensation plans and job descriptions.

Staff recommends approval of these items.

A handwritten signature in black ink, appearing to read "Catherine Wilson", with a long horizontal flourish extending to the right.

Catherine Wilson, Human Resources Director

DBCompensation™ SOFTWARE License and Support Agreement

This DBCompensation™ SOFTWARE License and Support Agreement, hereinafter referred to as AGREEMENT, is made and entered into as of the dates set forth below by and between DB Squared, LLC, an Arkansas Limited Liability Company, hereinafter referred to as DB SQUARED, and

City of Midwest City, OK

hereinafter referred to as LICENSEE.

WITNESSETH:

WHEREAS, LICENSEE is desirous of licensing DBCompensation™ SOFTWARE from DB SQUARED and receiving support for the DBCompensation™ SOFTWARE and DB SQUARED is desirous of providing said licenses and support services to LICENSEE, pursuant to the terms and conditions more particularly described herein;

NOW THEREFORE, for and in consideration of the premises, the terms and conditions herein and for other good and valuable consideration, the receipt, adequacy and sufficiency of which are hereby acknowledged, DB SQUARED and LICENSEE hereby agree as follows:

- 1. Rates, Amounts and Taxes Applicable to this AGREEMENT.** The rates and amounts listed in this section constitute an offer by DB Squared that shall be null and void if not accepted by LICENSEE by the OFFER EXPIRATION DATE. Rates and amounts shown here do not include applicable federal, state or local taxes or any other type of tax which might be applicable to this agreement. Applicable taxes will be added at the time of invoicing.

The EFFECTIVE DATE of this AGREEMENT shall be	July 1, 2019
The EMPLOYEE COUNT RANGE on which this AGREEMENT is based is	450 - 525
The DBCompensation™ SOFTWARE One-Time Licensing The DBCompensation™ SOFTWARE Tech Support Fee for 7/2019 - 6/2020 This annual fee covers software upgrades released during agreement term.	Paid \$166.67 per month
The TERM OF THE AGREEMENT shall be	12 months
The optional annual renewal fee after the term 12 months will be:	\$2,000 per year
Training provided to LICENSEE at no additional cost shall be and be provided via Internet connection.	N/A
All applicable taxes shall be	N/A
The optional MARKET UPDATE FEE shall be and due upon completion of the market update	\$5,000
Optional JOHANSON GROUP CONSULTING FEE shall be and due upon invoice of services provided	\$150 per hour

2. Definitions

- 2.1 **"DBCompensation™ SOFTWARE"** means the object code version of the JOB EVALUATION AND SALARY ADMINISTRATION MODULE with a perpetual license secured by DB Squared, LLC. All rights reserved), any UPDATES and UPGRADES thereto, and any related user guides, instructions, and reference materials provided to LICENSEE.
- 2.2 **"UPDATE"** means any subsequent minor modification of, or patch to, the DBCompensation™ SOFTWARE.
- 2.3 **"UPGRADE"** means any major new release of the DBCompensation™ SOFTWARE. The term UPGRADE does not include other MODULES.
- 2.4 **"MODULE"** means any software which constitutes a separate product offering by DB SQUARED.
- 2.5 **"DBCompensation™ METHODOLOGY"** means a methodology developed for the purpose of prescribing the process and structure for fairly and equitably determining job classification salary ranges and employee pay rates. The DBCompensation™ METHODOLOGY is proprietary to Johanson Consulting, Inc., d.b.a., Johanson Group, an affiliate of DB SQUARED.
- 2.6 **"LICENSEE"** means the legal entity which is a party to this AGREEMENT. It does include subsidiaries of LICENSEE or other third parties. For the purposes of this AGREEMENT, the term "third party" means anyone other than LICENSEE.
- 2.7 **"EMPLOYEE COUNT RANGE"** means the number of employees on which this AGREEMENT is based. Fees for this AGREEMENT are based on the number of full-time employees within the employee count range.

3. Licenses

- 3.1 **DBCompensation™ SOFTWARE License.** DB SQUARED hereby grants LICENSEE a nonexclusive, nontransferable license to operate (but not to sublicense) DBCompensation™ SOFTWARE on the internet hosted platform. Under this license, the DBCompensation™ SOFTWARE may be used with up to the number of employees specified in the EMPLOYEE COUNT in section 1 plus twenty percent.
- 3.2 **DBCompensation™ SOFTWARE License Termination.** DB SQUARED may terminate this DBCompensation™ SOFTWARE License if LICENSEE breaches this AGREEMENT. Upon termination of the license, LICENSEE will not have access to the DBCompensation™ Internet Hosted SOFTWARE. If this AGREEMENT is terminated for any reason prior to the end of the INITIAL TERM, the license will automatically terminate. Except as provided herein, if this AGREEMENT is terminated after the end of the INITIAL TERM, and LICENSEE does not opt for self-renewing annual AGREEMENT provision, then the license and access to the Internet Hosted SOFTWARE shall terminate.
- 3.3 **Limitations on License.** LICENSEE may not: (a) modify, translate or create derivatives of the DBCompensation™ SOFTWARE and METHODOLOGY; (b) operate the DBCompensation™ SOFTWARE in connection with any methodology other than the DBCompensation™ METHODOLOGY for which it was designed; or (c) permit any access to, or use of, the DBCompensation™ SOFTWARE by any third party. If LICENSEE violates provision (a) above, LICENSEE hereby quitclaims and assigns all intellectual property rights arising therefrom to DB SQUARED, and shall take all necessary steps to perfect DB SQUARED'S title therein. No rights are granted except as expressly set forth in this AGREEMENT, and no right or forbearance may be construed under any theory of implication, estoppel or otherwise.
- 3.4 **Ownership of DBCompensation™ SOFTWARE and DBCompensation™ METHODOLOGY.** The DBCompensation™ SOFTWARE and DBCompensation™ METHODOLOGY are owned by DB SQUARED and/or its affiliates. This AGREEMENT does not confer any ownership of the DBCompensation™ SOFTWARE or the DBCompensation™ METHODOLOGY to LICENSEE.

4. Support and Training

- 4.1 **Generally.** DB SQUARED will provide the following support for the DBCompensation™ SOFTWARE licensed hereunder, in accordance with DB SQUARED'S standard software support policies, as may be amended by DB SQUARED from time to time in its sole discretion: (a) DBCompensation™ SOFTWARE UPDATES AND UPGRADES; (b) telephone and/or e-mail consultation on use of the DBCompensation™ SOFTWARE and DBCompensation™ METHODOLOGY; and (c) assistance in error isolation and correction.
- 4.2 **LICENSEE Support Obligations.** LICENSEE agrees to test and verify any suspected error or defect in the DBCompensation™ SOFTWARE and to report such errors or defects to DB SQUARED in a timely manner. Upon request, LICENSEE agrees to provide DB SQUARED with reasonable assistance in reproducing such errors or defects.
- 4.3 **Limitations.** DB SQUARED'S support is limited to the DBCompensation™ SOFTWARE and DBCompensation™ METHODOLOGY.
- 4.4 **Training.** DB SQUARED will provide training on the use of the DBCompensation™ SOFTWARE AND DBCompensation™ METHODOLOGY to LICENSEE as specified in section 1 of this AGREEMENT.
- 4.5 **Market Updates.** If LICENSEE has elected in section 1 to receive optional market updates, then 1) DB SQUARED agrees to provide optional market updates to LICENSEE on an as needed basis during the term of this AGREEMENT, and 2) LICENSEE agrees to provide salary data to DB SQUARED when the optional market update has been request during the term of this AGREEMENT. LICENSEE understands that said salary data will be included in a study which will be made available to clients of DB SQUARED and/or its affiliates and that LICENSEE is not entitled to remuneration for the use of said salary data. DB SQUARED agrees that it will make said salary data available only in a consolidated form using market averages and that it will not publish the details of any specific LICENSEE'S salary data. Salary data to be provided to DB SQUARED by LICENSEE shall include the following: job titles used by LICENSEE, salaries associated with employees having said job titles and points associated with said job titles. Salary data will not include employee names.
- 4.6 **UPDATES and UPGRADES.** LICENSEE shall be entitled to UPDATES and UPGRADES to the DBCompensation™ SOFTWARE only as long as 1) this AGREEMENT remains in force, 2) the LICENSEE has not been notified that they are in breach of this AGREEMENT, and 3) all fees which are due to DB SQUARED from LICENSEE have been paid.
- 5. Fees and Timing of Payments**
- 5.1 **DBCompensation™ SOFTWARE License Fee.** The Software License Fee is based on the EMPLOYEE COUNT RANGE specified in section 1 and is a one-time fee which is due and payable at the signing of this AGREEMENT. This fee is non-refundable.
- 5.2 **DBCompensation™ SOFTWARE Support Fee.** The Software Support Fee is based on the EMPLOYEE COUNT RANGE specified in section 1 and is an annual fee, and it will be paid on the anniversary dates of this agreement.
- 5.3 **MARKET UPDATE FEE.** The MARKET UPDATE FEE is based on a flat dollar amount as specified in section 1 and is due and payable upon completion of the update. If no MARKET UPDATE FEE is charged to LICENSEE, then no market update service will be provided to LICENSEE under this AGREEMENT.

6. Term and Termination of AGREEMENT

- 6.1 **Term.** This AGREEMENT will take effect upon the date specified above and will remain in effect for a minimum amount of time referred to as the INITIAL TERM of the AGREEMENT, as specified in section 1 of this AGREEMENT. This AGREEMENT will self-renew on an annual basis after the INITIAL TERM unless terminated by LICENSEE or DB SQUARED.
- 6.2. **Termination.** Either LICENSEE or DB SQUARED may terminate this AGREEMENT upon completion of the INITIAL TERM by a thirty (30) day written notice to the other party. DB SQUARED may terminate this AGREEMENT at any time if LICENSEE breaches this AGREEMENT and fails to cure such breach within thirty (30) calendar days following notice of such breach.
- 6.3 **Survival of Obligations.** The following provisions will survive termination of this Agreement for any reason: (a) Sections 3.3, 4.3, 7.1, 7.2, 8.2, 8.3, 8.4 and 9 (all paragraphs); and (b) any provision that expressly indicates it will survive.

7. Confidentiality and Proprietary Notices

- 7.1 **Nondisclosure and Nonuse.** The DBCompensation™ SOFTWARE, the DBCompensation™ METHODOLOGY, and the details of the use, operation and performance thereof, are confidential to DB SQUARED and its affiliates. To the extent the analyses and outputs produced by the DBCompensation™ Software are or become subject to laws and regulations pertaining to privacy, consumer information, or otherwise, they may constitute confidential information of LICENSEE's salary administration program. LICENSEE may allow its employees and contractors ("personnel") access to confidential information provided that: (a) such access is limited to a "need to know" basis; (b) all such personnel are bound under confidentiality and non-use restrictions substantially similar to those contained herein; and (c) upon termination of any personnel, such personnel no longer retain access to any confidential information. LICENSEE may not use or disclose to any third party any confidential information associated with the DBCompensation™ SOFTWARE or the DBCompensation™ METHODOLOGY except as permitted by this AGREEMENT or as authorized by the prior written consent of DB SQUARED.
- 7.2 **Proprietary Marks.** LICENSEE agrees not to alter, change, or remove from the DBCompensation™ SOFTWARE any proprietary mark of DB SQUARED or its affiliates, including, patent, copyright, trade secret, trademark, or other intellectual property right notices.

8. Warranty; Indemnification

- 8.1 **Warranties.** DB SQUARED warrants, during the term of this AGREEMENT, that: (a) the internet hosted account on which the DBCompensation™ SOFTWARE is delivered, is free from defects; and (b) the DBCompensation™ SOFTWARE licensed hereunder shall operate substantially in accordance with the specifications contained in the documentation accompanying the DBCompensation™ SOFTWARE. LICENSEE'S sole remedy for breach of the warranties shall be, at DB SQUARED'S sole discretion: (i) addressing internet hosted account accessibility; or (ii) modification of either the program code of the DBCompensation™ SOFTWARE or the associated documentation to bring them into compliance with each other.
- 8.2 **DISCLAIMER.** EXCEPT FOR THE PROVISIONS OF PARAGRAPH 8.1, NO REPRESENTATIONS OR WARRANTIES ARE MADE, OR MAY BE IMPLIED, WITH RESPECT TO THE SOFTWARE AND/OR ANY SERVICES PROVIDED HEREUNDER. DB SQUARED SPECIFICALLY DISCLAIMS ANY WARRANTIES OF MERCHANTABILITY OR FITNESS FOR A PARTICULAR PURPOSE. DB SQUARED, ITS DEVELOPERS AND AFFILIATES WILL NOT BE HELD LIABLE FOR ANY LIABILITY OR OUTCOME FROM LICENSEE'S USE OF THE DBCOMPENSATION™ SOFTWARE AS A MANAGEMENT SALARY ADMINISTRATION TOOL.

8.3. **HOLD HARMLESS.** LICENSEE SHALL HOLD DB SQUARED, ITS DEVELOPERS, AND AFFILIATES HARMLESS FROM ANY LOSS OR CLAIM RESULTING DIRECTLY FROM AND ATTRIBUTABLE TO LICENSEE'S USE OR POSSESSION OF THE DBCOMPENSATION SOFTWARE AND SHALL REIMBURSE DB SQUARED FOR THE LOSS CAUSED SOLELY BY LICENSEE'S USE OR POSSESSION OF THE DBCOMPENSATION SOFTWARE.

8.4. **LIMITATION ON LIABILITY.** EXCEPT FOR BREACHES OF SECTION 3.3, or 7.1, NEITHER PARTY SHALL BE LIABLE FOR ANY LOSS OF PROFITS, LOSS OR INTERRUPTION OF BUSINESS, LOSS OF USE OR DATA, OR FOR ANY INDIRECT, SPECIAL, INCIDENTAL OR CONSEQUENTIAL DAMAGES OF ANY KIND, EVEN IF SUCH PARTY HAS BEEN ADVISED OF THE POSSIBILITY OF SUCH DAMAGES.

9. General Terms

9.1. **Assignment.** Licensee may not assign any right or delegate any obligation under this AGREEMENT, or transfer this AGREEMENT, without prior written consent of DB SQUARED, and any such attempt shall be void.

9.2. **Waiver.** The failure of a party to enforce its rights with respect to a breach hereunder shall not constitute a waiver with respect to any other occurrence of breach. Except as otherwise specified, the rights and remedies of a party under this AGREEMENT are in addition to any other rights or remedies available at law or in equity

9.3. **Governing Law.** This AGREEMENT will be governed by the laws of the State of Oklahoma, U.S.A., without regard to choice of law/conflict of law principles. Each party submits to the jurisdiction of the federal and state courts in Oklahoma County, Oklahoma, and agrees that any action brought in connection with this AGREEMENT shall be exclusively brought in such courts.

9.4. **Severability.** In the event that any provision of this AGREEMENT is found to be invalid or unenforceable, it will be enforced to the extent permissible and the remainder of this AGREEMENT shall remain in full force and effect.

9.5. **Modifications.** Any modification of this AGREEMENT must be in writing and executed by an authorized representative of both parties.

9.6. **Construction.** The headers of this AGREEMENT are for convenience only. The verb "to include" (and all variations thereof) shall not be construed as a term of limitation, unless expressly indicated by the context in which it is used.

9.7. **Compliance with Applicable Laws.** LICENSEE shall at all times comply with all applicable laws and regulations in using the DBCompensation™ SOFTWARE, and shall defend and hold harmless DB SQUARED against any liability directly or indirectly resulting from LICENSEE's failure to comply with the foregoing.

9.8. **Notices.** LICENSEE shall send all communications to DB SQUARED as follows: 1) technical communications to Technical Director of Software; and 2) business and legal communications to General Counsel; at DB Squared, LLC, 2928 McKee Circle, Suite 119, Fayetteville, AR 72703, phone: 479-587-0151, fax: 479-521-5453.

9.9. **Complete Agreement.** This AGREEMENT represents the complete agreement between DB SQUARED and LICENSEE.

APPROVAL

AGENT ACKNOWLEDGES AND AGREES THAT: 1) AGENT IS AUTHORIZED TO ENTER INTO THE TERMS AND CONDITIONS OF THIS AGREEMENT ON BEHALF OF THE LICENSEE AND 2) BY EXECUTING THIS AGREEMENT, LICENSEE IS LEGALLY BOUND BY THE TERMS OF THIS AGREEMENT.

IN WITNESS WHEREOF, the parties have caused this AGREEMENT to be duly executed by their respective authorized representatives.

DB Squared, LLC.

City of Midwest City

By: 

By: _____

Name: Bruce Johanson

Name: _____

Title: Principal

Title: _____

Date: 5-1-2019

Date: _____

Witness: 



Human Resources
100 N. Midwest Boulevard
Midwest City, OK 73110
office 405.739.1235

Memorandum

TO: Honorable Mayor and Council

FROM: Catherine Wilson, Human Resources Director

DATE: May 14, 2019

RE: Discussion and consideration of entering into a contract to provide employee assistance and related services with Dan L. Benton, Licensed Professional Counselor for FY 2019/2020 to provide the Employee Assistance Program and related services to City employees at the rate of \$2.25 per employee per month, \$106.83 per initial assessment and \$62.44 per session.

There were no increases in the EAP contract from the past fiscal year.

The Employee Assistance Program is required by law of employers who perform random substance abuse testing as we do. The services provided continue to be well received and utilized by our employees and their family members.

Types of services the City, the employees and their family members have used have included fitness for duty exams, return to work counseling, following drug or alcohol offenses, traumatic disorder counseling, family counseling, and financial counseling.

This service is provided at a rate of \$2.25 per employee per month at approximately \$13,311.00, annually as this can vary with staffing level, and \$106.83 per initial assessment and \$62.44 per session these charges are assessed on a case by case basis.

Staff recommends approval.

Catherine Wilson, Human Resources Director

CONTRACT TO PROVIDE EMPLOYEE ASSISTANCE
PROGRAM AND RELATED SERVICES

This contract is made by and between the City of Midwest City, Oklahoma, hereafter referred to as CMC and Dan L. Benton, Licensed Professional Counselor (LPC), hereafter referred to as Dan L. Benton, LPC.

Dan L. Benton, LPC hereby agrees to provide services to CMC via an Employee Assistance Program, also referred to as an EAP, for the employees of CMC.

The provision of the services will follow the guidelines as outlined below:

1. Dan L. Benton, LPC will provide an educational program to the employees of CMC concerning the merits of the EAP and the procedures for securing its services. A description of services will be provided to employees by Dan L. Benton, LPC and is attached hereto and labeled as Attachment A.
2. Dan L. Benton, LPC will provide assessment and referral services for employees that either volunteer to access the EAP or employees mandated to access the EAP services including not more than six (6) counseling sessions with an option to extend services for two additional sessions in situations where resolution is thought to be within the two session extension. For extended services, Dan L. Benton, LPC may bill third party or utilize private pay for extended services.
3. Dan L. Benton, LPC will provide reports to CMC concerning the number of persons using the program and the range of referral reasons for services. A description of the reports, which will be provided to CMC under this contract, is attached hereto and labeled as Attachment B.
4. Dan L. Benton, LPC will provide procedural steps in complying with the Federal Drug Free Workplace Act and other state, local, or federal requirements that may be issued during the term of this contract.
5. Dan L. Benton, LPC agrees to indemnify, defend and hold harmless CMC, its officers, employees and agents from and against all losses, costs, expenses, including attorney's fees, claims, suits and judgments, whatsoever, in connection with injury to, or death of, any persons, or loss of or damage to property resulting from any and all operations performed by Dan L. Benton, LPC, its officers, employees and agents under any of the terms of this contract.
6. At any time during the term of this contract that Dan L. Benton, LPC has personnel doing work and furnishing necessary labor or services arising from this contract, the CMC must be fully protected by Dan L. Benton, LPC having the following:
 - a. Worker's Compensation Insurance as required by law, and Dan L. Benton, LPC shall require any and all subcontractors to similarly provide Worker's Compensation Insurance for all of the latter's employees who are engaged in such work unless such employees are covered by the protection afforded by Dan L. Benton, LPC insurance.

- b. Liability insurance, applicable to performance of the contract in an amount not less than one hundred thousand (\$100,000.00) to any claimant for any claim for injury to any person, including death or property damage, and one million dollars (\$1,000,000.00), for any number of claims arising out of a single event or occurrence, which may arise in the course of Dan L. Benton, LPC performing work or services under this contract for CMC.
7. Should any of the required insurance policies be canceled, non-renewed, or materially modified before the expiration date, the issuing company will provide thirty (30) days written notice to CMC before the expiration, modification or cancellation date of said policy or policies.
8. The relationship of CMC and Dan L. Benton, LPC is that of an independent contractor. This contract does not establish, nor is it intended to establish, a principal-agent relationship.
9. This contract may be terminated by either CMC or Dan L. Benton, LPC should any party fail to perform any of the obligations described herein. Provided that, prior to terminating this contract, the party seeking to terminate the contract shall provide written notice of the default to the party in default and the party in default shall have thirty (30) days after the receipt of the notice of the default to cure the alleged default. If the default is cured prior to the expiration of the thirty (30) days after receipt of the notice of default, the contract shall not be terminated because of a failure to perform an obligation under this contract.
10. This contract may be terminated by either party, CMC or Dan L. Benton, LPC for any reason whatsoever by providing ninety (90) days written notice to the other party prior to the expected termination date.
11. All notices, communications and contacts required by this contract shall be written and shall be made by hand delivering or depositing in the United States mail, return receipt requested, to the following:

If to Dan L. Benton, LPC
Dan L. Benton, LPC
1212 S. Air Depot, Suite 43
Midwest City, OK 73110

If to CMC
Catherine Wilson
Human Resources Director
City of Midwest City
100 N. Midwest Blvd.
Midwest City, OK 73110

12. This contract shall not be assigned, transferred or modified without the written consent of both CMC and Dan L. Benton, LPC.
13. CMC agrees to provide Dan L. Benton, LPC with a bi-annual roster of full-time employees.
14. Dan L. Benton, LPC agrees to provide the services described for the amount of two dollars and twenty-five cents (\$2.25) per month full-time employee. Dan L.

Benton, LPC also agrees to provide services to employees who have been mandated by CMC for one hundred six dollars and eighty-three cents (\$106.83) which is the initial assessment and sixty-two dollars and forty-four cents (\$62.44) for each additional session. Dan L. Benton, LPC will provide monthly invoices setting forth the services performed and charges for those services to CMC, and CMC shall pay submitted invoices within thirty (30) days of receipt of the invoice.

15. The term of this Contract shall be one (1) year, commencing on **July 1, 2019 and ending June 30, 2020.**
16. Any agreement to extend or renew this contract will require both parties to agree to stated terms and any modifications, and enter into a new, extended or modified contract.
17. This is a lawful and binding contract entered into subject to the laws of the State of Oklahoma.
18. Wherefore, in agreement to the mutual terms, conditions, covenants and obligations set forth above, the parties have set forth their hands below on this 14th day of May 2019.

CITY OF MIDWEST CITY, INC.

Dan L. Benton, LPC

Matthew D. Dukes II, Mayor
City of Midwest City, OK

Dan L. Benton, LPC
Licensed Professional Counselor

ATTEST:

Sara Hancock, City Clerk Date

APPROVED as to form and legality this _____ day of _____, 2019.

Heather Poole, City Attorney Date

ATTACHMENT "A"

In order to provide the quality Employee Assistance Program services to the employees and family members of CMC, Dan L. Benton, LPC agrees to provide the following services:

1. Assessment/evaluation, referral to appropriate community service providers, and/or short-term counseling not to exceed six (6) sessions unless third party or private pay arrangements are made.
2. Services are applicable to the employee and members of their immediate household. Services will be made available to youth and families of the referred employee to ensure the most appropriate and comprehensive service plans which are utilized to establish employee and family well-being.
3. Dan L. Benton, LPC will provide follow-up no more than six months following the last session with the employee.
4. Dan L. Benton, LPC will provide management consultation to supervisors regarding problem employees on the phone or in person at Dan L. Benton, LPC office.
5. Dan L. Benton, LPC will maintain accurate records of EAP participants in accordance with all applicable state and federal statutes regarding confidentiality.
6. Twenty-four hour answering service is available in case of employee crisis.

ATTACHMENT "B"

REPORTING: Dan L. Benton, LPC shall report the following information on a quarterly basis to CMC:

1. The number of employees or family members seen with demographic data.
2. The type of referrals, issues or problems, if necessary.
3. The average number of sessions utilized.



Human Resources
100 N. Midwest Boulevard
Midwest City, OK 73110
office 405.739.1235

Memorandum

Date: May 14, 2019

To: Honorable Mayor and Council

From: Catherine Wilson, Human Resources Director

Re: Discussion and consideration of entering into a contract to provide employee assistance and related services with Stacey A. Stephens, a Licensed Professional Counselor (LPC) for the FY 2019/2020 to provide the Employee Assistance Program (EAP) and related services at the rate of \$2.25 per employee per month, \$106.83 charge per initial assessment and \$62.44 per session. In addition Ms. Stephens will provide lead or assistance to lead counselor in conducting post critical incident group debriefing services at a fee of \$100 per debrief, as requested by the City.

Costs associated with the EAP are budgeted in the Employee Life and Health Fund and were budgeted for the FY 2019/2020 as a \$12,600 expense which may fluctuate depending on the number of mandated employees and/or critical incidents for which Ms. Stephens is asked to handle.

This will be Ms. Stacey Stephens' second year to provide services to the Police Department and other City employees or their family members with issues specific to Post Traumatic Stress Syndrome (PTSD). Ms. Stephens specializes in Critical Incidents and has provided her services to us this year in this capacity. Her services over this past year have enhanced the program we are providing our employees and has given them a choice of LPCs.

Ms. Stephens has agreed to provide her services at the same rates as her current contract states, these rates are \$2.25 per employee per month fee, and for mandated issues there is a \$106.83 charge per initial assessment and \$62.44 per session. In addition Ms. Stephens will provide lead or assistance to lead counselor in conducting critical incident debriefing services at a flat rate of one hundred (\$100) dollars per debriefing at the City's request.

The Employee Assistance Program is required by law of employers who perform random substance abuse testing as we do. The services provided continue to be well received and utilized by our employees and their family members. The types of services the City's employees, and their family members, have used included fitness for duty exams, return to work counseling, following drug or alcohol offenses, traumatic disorder counseling, family counseling, and financial counseling.

Staff recommends approval.

A handwritten signature in black ink, appearing to read "Catherine Wilson", with a stylized flourish at the end.

Catherine Wilson, MPA

HR Director

CONTRACT TO PROVIDE EMPLOYEE ASSISTANCE
PROGRAM AND RELATED SERVICES

This contract is made by and between the City of Midwest City, Oklahoma, hereafter referred to as CMC and Stacey A. Stephens, Licensed Professional Counselor (LPC), hereafter referred to as Stacey Stephens, LPC.

Stacey Stephens, LPC hereby agrees to provide services to CMC via an Employee Assistance Program, also referred to as an EAP, for the employees of CMC.

The provision of the services will follow the guideline as outlined below:

1. Stacey Stephens, LPC will provide an educational program to the employees of CMC concerning the merits of the EAP and the procedure for securing its services. A description of services will be provided to employees by Stacey Stephens, LPC and is attached hereto and labeled as Attachment A.
2. Stacey Stephens, LPC will provide assessment and referral services for employees that either volunteer to access the EAP or employees mandated to access the EAP services including not more than six (6) counseling sessions with an option to extend services for two additional sessions in situations where resolution is thought to be within the two session extension. For extended services Stacey Stephens, LPC may bill third party or utilize private pay for extended services.
3. Stacey Stephens, LPC will provide reports to CMC concerning the number of persons using the program and the range of referral reasons for services. A description of the reports, which will be provided to CMC under this contract attached hereto and labeled as Attachment B.
4. Stacey Stephens, LPC will provide guidance for complying with the Federal Drug Free Workplace Act and other state, local or federal requirements that may be issued during the term of the contract.
5. Stacey Stephens, LPC agrees to indemnify, defend and hold harmless CMC, its officers, employees and agents from and against all losses, costs, expenses, including attorney's fees, claims, suits and judgments, whatsoever, in connection with injury to, or death of, any persons, or loss of or damage to property resulting from any and all operations performed by Stacey Stephens, LPC, its officers, employees and agents under any of the terms of this contract.
6. At any time during the term of this contract that Stacey Stephens, LPC has personnel doing work and furnishing necessary labor or services arising from this contract, the CMC must be fully protected by Stacey Stephens, LPC have the following:
 - a. Worker's Compensation Insurance as required by law, and Stacey Stephens, LPC shall require any and all subcontractors to similarly provide Worker's Compensation Insurance for all of the latter's employees who are engaged in such work unless such employees are covered by the protection afforded by Stacey Stephens, LPC insurance.

- b. Liability insurance, applicable to performance of the contract in an amount not less than one hundred thousand (\$100,000.00) to any claimant for any claim for injury to any person, including death or property damage, and one million dollars (\$1,000,000.00), for any number of claims arising out of a single event or occurrence, which may arise in the course of Stacey Stephens, LPC performing work or services under this contract for CMC.
7. Should any of the required insurance policies be canceled, non-renewed, or materially modified before the expiration date, the issuing company will provide thirty (30) days written notice to CMC before the expiration, modification or cancellation date of said policy or policies.
8. The relationship of CMC and Stacey Stephens, LPC is that of an independent contractor. This contract does not establish, nor is it intended to establish, a principal-agent relationship.
9. This contract may be terminated by either CMC or Stacey Stephens, LPC should any party fail to perform any of the obligations described herein. Provided that, prior to terminating this contract, the party seeking to terminate the contract shall provide written notice of the default to the party in default and the party in default shall have thirty (30) days after the receipt of the notice of the default to cure the alleged default. If the default is cured prior to the expiration of the thirty (30) days after receipt of the notice of default, the contract shall not be terminated because of a failure to perform an obligation under this contract.
10. This contract may be terminated by either party, CMC or Stacey Stephens, LPC for any reason whatsoever by providing ninety (90) days written notice to the other party prior to the expected termination date.
11. All notices, communications and contacts required by this contract shall be written and shall be made by hand delivering or depositing in the United States mail, return receipt requested, to the following:

If to Stacey Stephens, LPC

Stacey Stephens, LPC
44038 E. 45th
Shawnee, OK 74804

If to CMC

Catherine Wilson
Human Resources Director
City of Midwest City
100 N. Midwest Blvd.
Midwest City, OK 73110

12. This contract shall not be assigned, transferred or modified without the written consent of both CMC and Stacey Stephens, LPC.
13. CMC agrees to provide Stacey Stephens, LPC with a bi-annual roster of full-time employees.

14. Stacey Stephens, LPC agrees to provide the services described for the amount of two dollars and twenty-five cents (\$2.25) per month full-time employee. Stacey Stephens, LPC also agrees to provide services to employees who have been mandated by CMC for one hundred six dollars and eighty-three cents (\$106.83) which is the initial assessment and sixty-two dollars and forty-four cents (\$62.44) for each additional session. Stacey Stephens, LPC will provide lead or assistant lead services for a post critical incident group debrief as requested by CMC for the amount of one hundred dollars (\$100 per debrief). Stacey Stephens, LPC will provide monthly invoices setting forth the services performed and charges for those services to CMC, and CMC shall pay submitted invoices within thirty (30) days of receipt of the invoice.
15. The term of this contract is for the FY 2019/2020 to be effective July 1, 2019 through June 30, 2020.
16. Any agreement to extend or renew this contract will require both parties to agree to stated terms and any modifications, and enter into a new, extended or modified contract.
17. This is a lawful and binding contract entered into subject to the laws of the State of Oklahoma.
18. Wherefore, in agreement to the mutual terms, conditions, covenants and obligations set forth above, the parties have set forth their hands below on the 14 day of May 2019.

CITY OF MIDWEST CITY, INC.

Stacey A. Stephens, LPC

Matthew D. Dukes II, Mayor
City of Midwest City, OK



Stacey A. Stephens, LPC
Licensed Professional Counselor

ATTEST:

APPROVED

as to form and legality ____ day of _____ 2019

City Clerk

Heather Poole, City Attorney

ATTACHMENT "A"

In order to provide the quality Employee Assistance program services to the employees and family members of CMC, Stacey Stephens, LPC agrees to provide the following services:

1. Assessment/evaluation, referral to appropriate community service providers, and/or short-term counseling not to exceed six (6) sessions unless third party or private pay arrangement are made.
2. Services are applicable to the employee and members of their immediate household. Services will be made available to youth and families of the referred employee to ensure the most appropriate and comprehensive service plans which are utilized to establish employee and family well-being.
3. Stacey Stephens, LPC will provide follow-up no more than six months following the last session of the employee.
4. Stacey Stephens, LPC will provide management consultation to supervisors regarding problem employees on the phone or in person at Stacey Stephens, LPC office.
5. Stacey Stephens, LPC will maintain accurate records of EAP participants in accordance with all applicable state and federal statutes regarding confidentiality.
6. Twenty-four hour answering service is available in case of employee crisis.

ATTACHMENT "B"

REPORTING: Stacey Stephens, LPC shall report the following information on a quarterly basis to CMC:

1. The number of employees or family members seen with demographic data.
2. The type of referrals, issues or problems, if necessary.
3. The average number of sessions utilized.



Public Works Administration
Vaughn Sullivan, Director
vsullivan@midwestcityok.org
R. Paul Streets, Assistant Director
rstreets@midwestcityok.org
8730 S.E. 15th Street,
Midwest City, Oklahoma 73110
O: 405-739-1060 /Fax: 405-739-1090

Memorandum

TO: Honorable Mayor and Council

FROM: Vaughn Sullivan, Public Works Director

DATE: May 14, 2019

SUBJECT: Discussion and consideration of approving and entering into an agreement in the amount of \$6,000 with Production Essentials, LLC to provide a sound system and sound system services associated with entertainment in Regional Park as part of the 2019 Tribute to Liberty 4th of July celebration.

The Tribute to Liberty event will be similar to last year's event with Dr. Irvine Wagner's 50 piece concert band as headliner entertainment. Once again, the evening's grand finale will be fireworks choreographed to patriotic music. Staff has successfully negotiated an agreement with Production Essentials, LLC in the amount of \$6,000 for sound system rental and sound system services associated with the performance of the 50-piece concert band.

Staff recommends approval.

Vaughn Sullivan
Public Works Director

Attachment: Production Essentials Agreement



Public Works Administration
Vaughn Sullivan, Director
vsullivan@midwestcityok.org
R. Paul Streets, Assistant Director
rstreets@midwestcityok.org
8730 S.E. 15th Street,
Midwest City, Oklahoma 73110
O: 405-739-1060 /Fax: 405-739-1090

Tribute to Liberty Sound Services

Agreement

The City of Midwest City would like to provide musical entertainment during the 2019 Tribute to Liberty where members of Production Essentials, LLC (the "Sound") will provide the sound services for musical entertainment in a designated area of Joe B. Barnes Regional Park on Wednesday, July 4, 2019 from 6:00 p.m. until 10:30 p.m. The City of Midwest City and the Sound each agree to be responsible for the following tasks ensuring successful event execution:

The City of Midwest City will:

1. Provide the location; and
2. Provide assistance with local publicity and public relations; and
3. Provide staging, sound and lighting; and
4. Provide electricity; and
5. Provide designated parking areas for Sound members; and
6. Provide a tented area for Sound members and equipment; and
7. Provide port-a-potties near tent area; and
8. Provide fireworks show soundtrack up to three days prior to show date of July 4, 2019; and
9. Provide assistance in resolving other support issues that might arise; and
10. Provide compensation of \$6,000 to Sound upon the completion of the event.

The Sound will:

1. Provide sound equipment including speakers and speaker towers, mics, mic stands, sound boards and sound staff; and
2. Provide proof of insurance; and
3. Provide concert related sound services for opening acoustic duo from 6:00 p.m. until 7:50 p.m. and headline 50 piece concert band from 8:30 p.m. until 9:45 p.m. on July 4, 2019; and
4. Provide sound services for fireworks show from 9:45 p.m. until 10:30 p.m.; and
5. Clean the area used when the event ends; and
6. Address and/or resolve other situations that might arise.

Matthew D. Dukes II, Mayor Date
City of Midwest City

David Brecheen Date
Production Essentials, LLC

Attest:

City Clerk

APPROVED as to form and legality this _____ day of _____, 2019.

City Attorney



Public Works Administration
Vaughn Sullivan, Director
vsullivan@midwestcityok.org
R. Paul Streets, Assistant Director
rstreets@midwestcityok.org
8730 S.E. 15th Street,
Midwest City, Oklahoma 73110
O: 405-739-1060 /Fax: 405-739-1090

Memorandum

TO: Honorable Mayor and Council

FROM: Vaughn Sullivan, Public Works Director

DATE: May 14, 2019

SUBJECT: Discussion and consideration of approving and entering into an agreement in the amount of \$12,000 with Dr. Irvin L. Wagner, Professor of Music at University of Oklahoma, for a 50-piece concert band to provide the headliner entertainment in Regional Park as part of the 2019 Tribute to Liberty 4th of July celebration.

The Tribute to Liberty event will be similar to last year, with live music and an evening finale of fireworks choreographed to patriotic music. Staff has successfully negotiated an agreement again this year with Dr. Irvin L. Wagner, David Ross Boyd and Regents Professor of Music at University of Oklahoma, in the amount of \$12,000 for a 50-piece concert band to provide the evening's headliner entertainment. Last year was Dr. Wagner's sixth year to perform at the Tribute to Liberty event and his band's performance received great reviews from attendees of all ages.

Staff recommends approval.

Vaughn Sullivan
Public Works Director

Attachment: Dr. Irv Wagner Agreement



Public Works Administration
Vaughn Sullivan, Director
vsullivan@midwestcityok.org
R. Paul Streets, Assistant Director
rstreets@midwestcityok.org
8730 S.E. 15th Street,
Midwest City, Oklahoma 73110
O: 405-739-1060 /Fax: 405-739-1090

Tribute to Liberty Musical Entertainment Services Agreement

The City of Midwest City would like to provide musical entertainment during the 2019 Tribute to Liberty where members of Dr. Irv Wagner’s Concert Band (the “Band”) will play a patriotically themed concert in a designated area of Joe B. Barnes Regional Park on Wednesday, July 4, 2019 from 8:30 p.m. until 9:45 p.m. The City of Midwest City and the Band each agree to be responsible for the following tasks ensuring successful event execution:

The City of Midwest City will:

1. Provide the location; and
2. Provide assistance with local publicity and public relations; and
3. Provide staging, sound and lighting; and
4. Provide electricity; and
5. Provide designated parking areas for Band members; and
6. Provide a tented area for Band members and equipment; and
7. Provide port-a-potties near tent area; and
8. Provide assistance in resolving other support issues that might arise; and
9. Provide compensation of \$12,000 to the Band.

The Band will:

1. Provide a concert band; and
2. Provide all musical instruments, chairs, music stands and stand lighting; and
3. Play patriotically themed music from 8:30 p.m. until 9:45 p.m. on July 4, 2019; and
4. Clean the area used when the event ends; and
5. Address and/or resolve other situations that might arise.

Matthew D. Dukes II, Mayor Date

Dr. Irv Wagner Date
Dr. Irv Wagner’s Concert Band

Attest:

City Clerk

APPROVED as to form and legality this _____ day of _____, 2019.

City Attorney



City of Midwest City Police Department

100 N. Midwest Boulevard

Midwest City, OK 73110

Office 405.739.1320

Fax 405.739.1398

MEMORANDUM

TO: Honorable Mayor and Council

FROM: Brandon Clabes, Chief of Police

DATE: May 14, 2019

SUBJECT: Discussion and consideration of renewing the Memorandum of Understanding with the Oklahoma Department of Mental Health and Substance Abuse Services for FY 2019/2020 in an amount not to exceed \$25,000, which establishes the terms and conditions under which the City participates in this program to identify eligible municipal offenders in Midwest City who are in need of behavioral health treatment services and fund supplies necessary to operate the screening program such as a computer or drug testing supplies in the amount of \$1,000.

The Midwest City Police Department operates the largest municipal jail in Oklahoma. It is a proven fact that a large percentage of these individuals suffer from mental health or substance abuse issues but are unable or unwilling to get necessary treatment. The City of Midwest City continues to work with the Oklahoma Department of Mental Health and Substance Abuse Services (ODMHSAS) through an innovative project that identifies eligible municipal offenders who are in need of behavioral health treatment services. In addition, the offenders who are approved for the program are linked to appropriate services and monitored for treatment compliance and substance abstinence. Statistics at this point shows the program is having positive results.

Successful completion of the program, known as the Diversion Project, could result in incentives to the participants that could potentially include misdemeanor charge reductions and dismissals. Also, it provides a foundation for the participant to become a productive citizen in society and reduce recidivism, not only in our facility but others throughout the state. This obviously lowers jail operating costs and population numbers.

As part of the MOU, the City of Midwest City agrees to provide financial support in the amount of \$26,000.00 and office space for a full time ODMHSAS certified, contracted treatment provider to coordinate the Diversion Project. ODMHSAS will provide limited financial responsibility of the Diversion Project; and provide training and analytical data for evaluation purposes.

The monies are budgeted for this project in the Impound Fee funds. This continues to be the first of its kind at a municipal level and possibly a national model to be used throughout the United States.

Staff recommends approval.

Brandon Clabes
Chief of Police

Attachment: Proposed MOU

MEMORANDUM OF UNDERSTANDING

Between the City Council of Midwest City, Oklahoma and the Oklahoma Department of Mental Health and Substance Abuse Services

This Memorandum of Understanding (MOU) is entered into by and between the City of Midwest City, Oklahoma (MWC) and the Oklahoma Department of Mental Health and Substance Abuse Services (ODMHSAS), cumulatively the "Parties".

WHEREAS, The City of Midwest City, along with the Midwest City Police Department and the Midwest City Prosecutor, have identified a need for certain municipal offenders to receive behavioral health treatment in order to reduce recidivism in the city jail., and

WHEREAS, ODMHSAS is willing to provide support to develop a pilot municipal jail diversion program for offenders who are in need of behavioral health treatment services and are approved for the program by the Midwest City Prosecutor, and

WHEREAS, the Parties agree to jointly fund a full-time project coordinator, and to separately provide other necessary funds as provided below,

NOW THEREFORE, the Parties agree as follows:

1. **PURPOSE:** The purpose of the pilot project is to identify eligible municipal offenders in Midwest City, Oklahoma who are in need of behavioral health treatment services. Offenders approved for the program will be linked to appropriate services and monitored for treatment compliance and substance abstinence. Further, MWC will recommend to the City Prosecutor and Judge of the Municipal Court that certain incentives be provided to participants for compliance with treatment services and/or substance abstinence, those incentives to potentially include misdemeanor charge reductions and dismissals. This project shall hereinafter be referred to as the "Diversion Project".
2. **PERIOD OF AGREEMENT:** The effective date of this MOU is July 1, 2019. This agreement shall remain in effect until either of the Parties provides written notice of cancellation with at least a 45 day notice, or June 30, 2020, whichever occurs first. The agreement is renewable for a further 1 year term, subject to the continuing sufficiency of legislative and municipal appropriations.
3. **MIDWEST CITY RESPONSIBILITIES:** The Midwest City Council hereby agrees to provide the following:
 - a. **FINANCIAL:** The Midwest City Council will provide the following financial support for the diversion project:
 - Fund the remaining half of the aforementioned full-time staff position. This person will be employed by the ODMHSAS certified, contracted treatment provider to coordinate the Diversion Project. MWC will provide to ODMHSAS, on a 12-month pro-rata basis, funds not to exceed in Twenty-five Thousand Dollars (\$25,000.00) annually, to be coupled with

ODMHSAS funds in a matching amount and paid by ODMHSAS to the contracted provider to fund the Diversion Project Coordinator position.

- Fund supplies necessary to operate the screening program, such as a computer or drug testing supplies, as identified by the MWC Police Department and ODMHSAS in the amount of One Thousand Dollars (\$1,000.00) annually, through MWC-determined purchasing procedures.

b. **TRAINING:** The MWC Police Department will encourage all relevant staff, to include police officers jail staff and any other necessary parties to attend trainings provided by ODMHSAS, as referenced in 4.b.

c. **SCREENING:** The MWC Police Department will administer, as part of jail booking, validated behavioral health screens agreed upon for use by both Parties.

d. **DATA SHARING:** The MWC Police Department will provide the ODMHSAS with jail booking data for the prior three (3) years and monthly thereafter throughout the MOU period. The Parties agree that the MWC Police Department will share personally identifiable data which may include, but is not limited to offender names, social security numbers, dates of birth, arrest data, criminal charge information. The information may be shared in any appropriate and secure format or medium. Offenders will sign an appropriate release during the screening process for such data sharing.

4. **ODMHSAS RESPONSIBILITIES:** The ODMHSAS hereby agrees to provide the following:

a. **FINANCIAL:** The ODMHSAS will provide financial support for the Diversion Project by the following means:

- Fund the remaining half of the aforementioned full-time staff position. This person will be employed by the ODMHSAS certified, contracted treatment provider to coordinate the Diversion Project. MWC will provide to ODMHSAS, on a 12-month pro-rata basis, funds not to exceed in Twenty-five Thousand Dollars (\$25,000.00) annually, to be coupled with ODMHSAS funds in a matching amount and paid by ODMHSAS to the contracted provider to fund the Diversion Project Coordinator position.

- Fund treatment services with Red Rock Behavioral Health Services through established processes and fee for services rates, by the ODMHSAS certified, contracted treatment provider. ODMHSAS will provide, on a 12-month pro-rata basis, funds not to exceed the amount of Thirty Thousand Dollars (\$30,000.00) for these purposes.

b. **TRAINING:** The ODMHSAS will provide at least two (2) trainings per calendar year to the MWC Police Department and other necessary individuals to include diversion project purpose, goals, target population, screening instruments, and data collection.

c. **CONTRACTING:** The ODMHSAS will negotiate the contract with an ODMHSAS certified treatment provider for the purposes of hiring the aforementioned "Diversion

Project Coordinator” and for provision of treatment as described above. Diversion Project Coordinator shall support the daily work of the Diversion Project as well as serve as a point of contact and resource for Midwest City Police Department on assisting citizens in accessing the behavioral health service system.

- d. **TECHNICAL ASSISTANCE AND MONITORING:** The ODMHSAS shall provide technical assistance to the MWC Police Department and to MWC, as well as to any ODMHSAS certified, contracted treatment providers working with the Diversion Project on an as needed basis. Further, the ODMHSAS shall monitor any ODMHSAS certified, contracted treatment provider working with this Diversion Project for compliance with contract requirements.

IT IS SO AGREED this _____ day of _____ 2019.

Chief Brandon Clabes, for
Midwest City Police Department



ODMHSAS Commissioner

Heather Poole
City Prosecutor/City Attorney

Matthew D. Dukes II, Mayor
For the City Council of Midwest City, Oklahoma



The City of
MIDWEST CITY
COMMUNITY DEVELOPMENT DEPARTMENT -
ENGINEERING DIVISION

Billy Harless, Community Development Director
Patrick Menefee, P.E., City Engineer

ENGINEERING DIVISION
Patrick Menefee, City Engineer
CURRENT PLANNING DIVISION
Kellie Gilles, Manager
COMPREHENSIVE PLANNING
Petya Stefanoff, Comprehensive Planner
BUILDING INSPECTION DIVISION
Christine Brakefield, Building Official
GIS DIVISION
Greg Hakman, GIS Coordinator

TO : Honorable Mayor and City Council

FROM : Patrick Menefee, P.E., City Engineer

DATE : May 14th, 2019

SUBJECT : Discussion and consideration of accepting maintenance bonds from Mid-South Contracting, L.L.C. in the amount of \$1868.50 for the sewer line improvements located at 5600 Tinker Diagonal.

The one year maintenance bonds from Mid-South Contracting, L.L.C. are for the sewer line improvements installed in conjunction with the new Verizon store located at 5600 Tinker Diagonal.

Staff recommends acceptance as this is consistent with past policy.

Patrick Menefee, P.E.
City Engineer

Attachments

DEVELOPMENT – PAVING, WATER MAINS, STORM AND SANITARY SEWERS

MAINTENANCE BOND

Bond No.: GR40240

KNOW ALL BY THESE PRESENTS that we, Mid-South Contracting, LLC, as Principal, and Granite Re, Inc. as Surety, are held and firmly bound unto the City of Midwest City, Oklahoma, a municipal corporation in the state of Oklahoma, in the full and just sum of One Thousand Eight Hundred Sixty Eight and 50/100 (\$ 1,868.50), such sum being not less than ten percent (10%) of the total contract price to construct or install Sanitary Sewer for Verizon, Midwest City, OK (the "Improvement"), for a period of One (1) years after acceptance of the improvement by the City Council of the City of Midwest City (the "Maintenance Period"), for the payment of which, well and truly to be made, we, and each of us, bind ourselves, our heirs, executors and assigns, jointly and severally, firmly by these presents:

The conditions of this obligation are such that the Principal has by a certain contract between the Principal and TCS Construction dated the 16th day of February, 20 18, agreed to construct or install the Improvement in the City of Midwest City and to maintain the Improvement against any failures due to defective materials or workmanship during the Maintenance Period.

NOW, THEREFORE, if the Principal, during the Maintenance Period, shall maintain the Improvement against any failures due to defective materials or workmanship, then this obligation shall be void; otherwise it shall remain in full force and effect.

It is further agreed that if the Principal or the Surety shall fail to maintain the Improvement against any failures due to defective materials or workmanship for the Maintenance Period, and at any time repairs shall be necessary, that the cost of making the repairs shall be determined by the City Council of the City of Midwest City, or some person or persons designated by them to ascertain the cost of making the repairs. If, upon thirty (30) days notice, the Principal or the Surety do not make the repairs or pay the amount necessary to make the repairs, the amount necessary to make the repairs shall be due upon the expiration of thirty (30) days, and suit may be instituted to obtain the amount necessary to make the repairs and shall be conclusive upon the parties as to the amount due on this bond to make the repairs, and that the cost of all repairs shall be so determined from time to time during the Maintenance Period, as the condition of the Improvement may require.

Signed, sealed, and delivered this 14th day of March, 20 18

Mid-South Contracting, LLC
Principal

ATTEST:
City Clerk
Secretary

By [Signature]

Granite Re, Inc.
Surety

ATTEST:
Lauren Rogers, Witness
Secretary

By [Signature]
Jana Taylor, Attorney-in-Fact

Approved as to form and legality this ___ day of ___, 20 ___

City Attorney

Accepted by the City Council of the City of Midwest City this ___ day of ___, 20 ___

City Clerk

Mayor



MID-CON-01

ROGLA1

CERTIFICATE OF LIABILITY INSURANCE

DATE (MM/DD/YYYY)
03/14/2018

THIS CERTIFICATE IS ISSUED AS A MATTER OF INFORMATION ONLY AND CONFERS NO RIGHTS UPON THE CERTIFICATE HOLDER. THIS CERTIFICATE DOES NOT AFFIRMATIVELY OR NEGATIVELY AMEND, EXTEND OR ALTER THE COVERAGE AFFORDED BY THE POLICIES BELOW. THIS CERTIFICATE OF INSURANCE DOES NOT CONSTITUTE A CONTRACT BETWEEN THE ISSUING INSURER(S), AUTHORIZED REPRESENTATIVE OR PRODUCER, AND THE CERTIFICATE HOLDER.

IMPORTANT: If the certificate holder is an ADDITIONAL INSURED, the policy(ies) must have ADDITIONAL INSURED provisions or be endorsed. If SUBROGATION IS WAIVED, subject to the terms and conditions of the policy, certain policies may require an endorsement. A statement on this certificate does not confer rights to the certificate holder in lieu of such endorsement(s).

PRODUCER INSURICA - Oklahoma City 5100 N. Classen Blvd, #300 Oklahoma City, OK 73118	CONTACT NAME:	FAX (A/C, No): (405) 556-2332
	PHONE (A/C, No, Ext): (405) 523-2100	
INSURED Mid-South Contracting, LLC 8524 S Western Ave, Ste 113 Oklahoma City, OK 73139	E-MAIL ADDRESS:	
	INSURER(S) AFFORDING COVERAGE	NAIC #
	INSURER A : Continental Insurance Company	35289
	INSURER B : Continental Casualty Company	20443
	INSURER C : Transportation Insurance Company	20494
	INSURER D :	
	INSURER E :	
	INSURER F :	

COVERAGES CERTIFICATE NUMBER: REVISION NUMBER:

THIS IS TO CERTIFY THAT THE POLICIES OF INSURANCE LISTED BELOW HAVE BEEN ISSUED TO THE INSURED NAMED ABOVE FOR THE POLICY PERIOD INDICATED. NOTWITHSTANDING ANY REQUIREMENT, TERM OR CONDITION OF ANY CONTRACT OR OTHER DOCUMENT WITH RESPECT TO WHICH THIS CERTIFICATE MAY BE ISSUED OR MAY PERTAIN, THE INSURANCE AFFORDED BY THE POLICIES DESCRIBED HEREIN IS SUBJECT TO ALL THE TERMS, EXCLUSIONS AND CONDITIONS OF SUCH POLICIES. LIMITS SHOWN MAY HAVE BEEN REDUCED BY PAID CLAIMS.

INSR LTR	TYPE OF INSURANCE	ADDL INSD	SUBR WVD	POLICY NUMBER	POLICY EFF (MM/DD/YYYY)	POLICY EXP (MM/DD/YYYY)	LIMITS
A	<input checked="" type="checkbox"/> COMMERCIAL GENERAL LIABILITY <input type="checkbox"/> CLAIMS-MADE <input checked="" type="checkbox"/> OCCUR <input checked="" type="checkbox"/> Poll. Ded: \$1,000 GEN'L AGGREGATE LIMIT APPLIES PER: <input type="checkbox"/> POLICY <input checked="" type="checkbox"/> PRO-JECT <input type="checkbox"/> LOC OTHER:			6024523812	07/31/2017	07/31/2018	EACH OCCURRENCE \$ 1,000,000 DAMAGE TO RENTED PREMISES (Ea occurrence) \$ 100,000 MED EXP (Any one person) \$ 15,000 PERSONAL & ADV INJURY \$ 1,000,000 GENERAL AGGREGATE \$ 2,000,000 PRODUCTS - COMP/OP AGG \$ 2,000,000 POLLUTION \$ 1,000,000 COMBINED SINGLE LIMIT (Ea accident) \$ 1,000,000
A	<input checked="" type="checkbox"/> AUTOMOBILE LIABILITY <input checked="" type="checkbox"/> ANY AUTO OWNED AUTOS ONLY <input type="checkbox"/> SCHEDULED AUTOS <input type="checkbox"/> HIRED AUTOS ONLY <input type="checkbox"/> NON-OWNED AUTOS ONLY			6024523809	07/31/2017	07/31/2018	BODILY INJURY (Per person) \$ BODILY INJURY (Per accident) \$ PROPERTY DAMAGE (Per accident) \$ \$ \$ 5,000,000
B	<input checked="" type="checkbox"/> UMBRELLA LIAB <input checked="" type="checkbox"/> OCCUR <input type="checkbox"/> EXCESS LIAB <input type="checkbox"/> CLAIMS-MADE DED <input checked="" type="checkbox"/> RETENTION \$ 10,000			6024523843	07/31/2017	07/31/2018	EACH OCCURRENCE \$ 5,000,000 AGGREGATE \$ Aggregate \$ 5,000,000 PER STATUTE OTH-ER
C	<input checked="" type="checkbox"/> WORKERS COMPENSATION AND EMPLOYERS' LIABILITY ANY PROPRIETOR/PARTNER/EXECUTIVE OFFICER/MEMBER EXCLUDED? (Mandatory in NH) <input type="checkbox"/> Y/N If yes, describe under DESCRIPTION OF OPERATIONS below		N/A	6024523826	07/31/2017	07/31/2018	E.L. EACH ACCIDENT \$ 1,000,000 E.L. DISEASE - EA EMPLOYEE \$ 1,000,000 E.L. DISEASE - POLICY LIMIT \$ 1,000,000

DESCRIPTION OF OPERATIONS / LOCATIONS / VEHICLES (ACORD 101, Additional Remarks Schedule, may be attached if more space is required)
RE: Verizon Sanitary Sewer

CERTIFICATE HOLDER City of Midwest City 100 N Midwest Blvd. Midwest City, OK 73110	CANCELLATION SHOULD ANY OF THE ABOVE DESCRIBED POLICIES BE CANCELLED BEFORE THE EXPIRATION DATE THEREOF, NOTICE WILL BE DELIVERED IN ACCORDANCE WITH THE POLICY PROVISIONS.
	AUTHORIZED REPRESENTATIVE

VER
9.39



Rocky W. Chen, P.E.
Water Quality Division

Robert B. Walker
Construction Permitting Section

DESCRIPTION	QUANTITY
TRENCHING	478.1 LF
4' DIAMETER MANHOLE	2 EA
8" PVC SEWER PIPE	265.1 LF
8" DUCTILE IRON SEWER PIPE	214 LF

NOTES:

- 1.) TIE-IN ELEVATION IS ESTIMATED TO BE JUST ABOVE MANHOLE BASE. CONTRACTOR SHALL MAKE THE TIE-IN AS LOW AS POSSIBLE WITHOUT DAMAGING INTEGRITY OF THE BASE OF EXISTING MANHOLE.
- 2.) FEMA FLOODWAY IS SHOWN. BALANCE OF SITE & PROFILE IS FEMA ZONE AE.

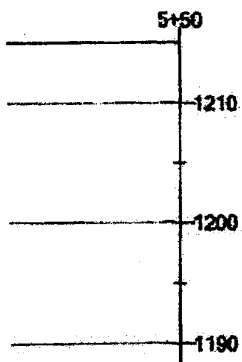

OWNER'S AFFIDAVIT OF ACCEPTANCE & CONTRACTOR'S LIEN WAIVER

PROJECT NAME: Verizon
PROJECT LOCATION: 5600 Tucker Diagonal
TYPE OF CONSTRUCTION: Sanitary Sewer

OWNER'S AFFIDAVIT OF ACCEPTANCE

I, the undersigned, hereby certify that the above construction was performed in an acceptable manner satisfactory to the owner of the above project and certify the cost of such project is \$ 18,685.⁰⁰ less the City of Midwest City, Engineering Division Inspection Fees.

By Tony Sporsone
OWNER

Date: 10-18-18

STATE OF Oklahoma)
COUNTY OF Cleveland)ss.

Before me, the undersigned Notary Public in and for the state and county aforesaid, on this 18th day of October, 2018, personally appeared Tony Sporsone, to me known to be the identical person(s) who executed the within and foregoing instrument and acknowledged to me that _____ executed the same as free and voluntary act and deed for the uses and purposes herein set forth.

My Commission expires: 4/25/22



[Signature]
NOTARY PUBLIC

CONTRACTOR'S LIEN WAIVER

This is to certify that all expenditures for labor and material for the construction of the above project has been paid. We, the undersigned, do here by waive and release all of our rights, claims and lien rights against this installation and improvements so constructed.

By [Signature]
CONTRACTOR

Date: 10/17/18

STATE OF Oklahoma)
COUNTY OF Oklahoma)ss.

Before me, the undersigned Notary Public in and for the state and county aforesaid, on this 17 day of October, 2018, personally appeared Curt Chappell, to me known to be the identical person(s) who executed the within and foregoing instrument and acknowledged to me that _____ executed the same as _____ free and voluntary act and deed for the uses and purposes herein set forth.

My Commission expires: Feb 11, 2021

[Signature]
NOTARY PUBLIC

REVISED: August 15, 2006 B&D

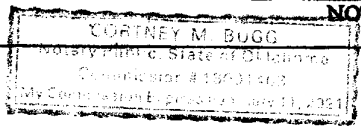



The City of Midwest City

NEIGHBORHOODS IN ACTION

1124 N. DOUGLAS BLVD. * MIDWEST CITY, OKLAHOMA,
73130 * (405) 736-1973 * FAX * (405) 869-9289

TO: Honorable Mayor and Council

FROM: Tom Bridgett, Neighborhoods in Action Coordinator

Date: May 14, 2019

Subject: Discussion and consideration of approving and entering into a contract in an amount not to exceed \$6,500.00 for fiscal year 2019-2020 with THICK DESCRIPTIONS ("TD") to establish the terms and conditions under which THICK DESCRIPTIONS will provide an extended week long S.T.E.A.M. (Science, Technology, Engineering, Anthropology, and Math) camp to NIA Youth Summer Camp participants.

THICK DESCRIPTIONS ("TD") will provide an extended week long S.T.E.A.M. (Science, Technology, Engineering, Anthropology and Math) camp to NIA Summer Camp participants (children between the ages of 8 and 12).

This contract, a copy which is attached for your review, provides for a comprehensive scope of services associated with S.T.E.A.M. to be provided to NIA Summer Youth Camp participants.

Staff recommends approval.

A handwritten signature in black ink, appearing to read "Tom Bridgett", is written over a horizontal line.

Tom Bridgett
Neighborhoods in Action Coordinator

Attachment (1)



Thick Descriptions Science Empowerment/Cultural Intelligence

THICK DESCRIPTIONS s.t.E.A.m. LEARNING JOURNEY CONTRACT

THIS CONTRACT is made and entered into this 14 day of May, 2019 by and between THICK DESCRIPTIONS, ("TD") and the City of Midwest City, a municipal corporation ("City").

City desires to enter into this contract with TD whereby TD will provide a s.t.e.A.m. (science, technology, engineering, Anthropology and math) Learning Journey to youth between the ages of 8 – 12.

Therefore, in consideration of the mutual conditions and agreements herein contained and, intending to be legally bound, the parties agree as follows:

- 1) TD agrees to provide camp services to City campers on Monday, June 10 -14, 2019 from 8:30 am. to 4:00pm. The purpose of this learning journey is to provide s.t.e.A.n. to youth. This learning journey is free to all attendees.
- 2) s.t.e.A.m. Learning Journey will accommodate up to 30 students (tweens between the ages of 8 – 12) in Midwest City, providing hands on instruction. The learning journey will be held at Neighborhoods in Action, Midwest City, Oklahoma. This year's theme is aviation.
- 3) The City shall pay TD \$6,500.00 to execute this learning journey.
- 4) A Certificate of Insurance must be provided by TD indicating minimum liability coverage in the amount of:
 - a) \$100,000.00 personal injury each accident or occurrence; and
 - b) \$1,000,000.00 aggregate (all claims for any one occurrence).
- 5) TD shall not be liable to the City and there will be no adjustment in the contract amount for days on which TD is unable to execute the camp through no fault of TD, such as adverse weather conditions.

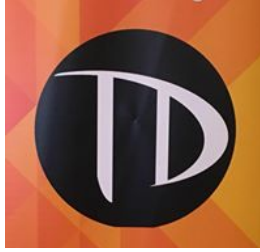

Thick Descriptions Science Empowerment/Cultural Intelligence

- 6) Any notice from one party to the other party concerning this contract shall be in writing and shall be given by certified mail, return receipt requested, or in person by hand delivery to Suzette V Chang, TD at 3810 N Tulsa, OKC, 73112 and NIA, Tom Bridgett, 1124 N Douglas Blvd, Midwest City, OK 73130.
- 7) Any changes to this contract must be presented and approved by both parties at least 48 hours in advance of the commencement date.
- 8) Any changes or modifications in the terms of this contract must have the signatures of both parties.

This contract represents the entire understanding between and among the parties concerning the subject matter hereof. Neither party may assign this contract.

The parties have approved and executed this contract, TD on the 26th day of

April 29, 2019 and City on the _____ day of _____, 2019.

Thick Descriptions
Oklahoma City, Oklahoma

City of Midwest City

Suzette V. Chang

SUZETTE V. CHANG, FOUNDER/CEO

MATTHEW D. DUKES, II Mayor

APPROVED as to form and legality this _____ day of _____, 2019

Heather Poole, City Attorney



The City of Midwest City

NEIGHBORHOODS IN ACTION

1124 N. DOUGLAS BLVD. * MIDWEST CITY, OKLAHOMA,
73130 * (405) 736-1973 * FAX * (405) 869-9289

TO: Honorable Mayor and Council

FROM: Tom Bridgett, Neighborhoods in Action Coordinator

Date: May 14, 2019

Subject: Discussion and consideration of approving and entering into a contract in an amount not to exceed \$2,200.00 for fiscal year 2019-2020 with Crutcho Public School to establish the terms and conditions under which Crutcho Public School will provide a school bus and driver for NIA Youth Summer Camp.

Crutcho Public School will provide transportation equipment ("buses") and bus operators ("drivers") for the transportation of Summer Camp participants (children between the ages of 8 and 12, and Neighborhoods in Action staff and volunteers) to and from Summer Camp activities at locations in the Oklahoma City metro area.

This contract, a copy which is attached for your review, provides for a comprehensive scope of services associated with the transportation of NIA Summer Youth Camp participants, staff and volunteers.

Staff recommends approval.

Tom Bridgett
Neighborhoods in Action Coordinator

Attachment (1)

CRUTCHO PUBLIC SCHOOL
Use of District Transportation Equipment
(School District Bus Lease Contract)

This contract is made and entered into by and between Crutcho Public School of Oklahoma County (“Crutcho”) and the City of Midwest City, a municipal corporation (“City”).

City desires to enter into this contract with Crutcho whereby Crutcho will provide transportation equipment (“buses”) and bus operators (“drivers”) for the transportation of Summer Camp participants (children between the ages of 8 and 12, and Neighborhoods in Action staff and volunteers) to and from Summer Camp activities at locations in the Oklahoma City metro area.

Therefore, in consideration of the mutual conditions and agreements herein contained and, intending to be legally bound, the parties agree as follows:

1. The transportation to be furnished by Crutcho under this contract will commence on June 10, 2019 and will terminate July 19, 2019.

2. City shall pay Crutcho \$21.00 per hour for each hour Crutcho provides City with transportation, including buses and drivers, for a maximum of 20 hours per week for a total of five weeks. During the term of this contract, total compensation that will be paid to Crutcho for transportation shall not exceed a total of \$2,200.00.

3. All buses provided by Crutcho for the performance of this contract will comply with Crutcho policies and regulations, and state laws, rules and regulations applicable to transportation equipment used to transport school children including, but not limited to, the rules of the Oklahoma State Department of Education.

4. Crutcho will be responsible for all fuel, repairs and maintenance for the buses, and replacement buses should the need arise.

5. Crutcho will provide a qualified driver who is an employee of Crutcho and who meets all the requirements to operate a school bus and transport school children in the State of Oklahoma.

6. A Certificate of Insurance must be provided by Crutcho indicating minimum liability coverage in the amount of:

- a) \$ 100,000.00 property damage;
- b) \$ 100,000.00 personal injury each accident or occurrence; and
- c) \$1,000,000.00 aggregate (all claims for any one occurrence).

7. Crutcho shall not be liable to City and there will be no adjustment in the contract amount for days on which Crutcho’s buses are unable to operate through no fault of Crutcho, such as adverse weather conditions.

8. Any notice from one party to the other party concerning this contract shall be in writing and shall be given by certified mail, return receipt requested, or in person by hand delivery to Crutchto at 2401 North Air Depot Boulevard, Oklahoma City, Oklahoma 73141 or to City at 100 North Midwest Boulevard, Midwest City, Oklahoma 73110.

9. Any changes to this contract must be presented and approved by both parties at least 48 hours in advance of the commencement date.

10. Any changes or modifications to the terms of this contract must have the signatures of both parties.

This contract represents the entire understanding between and among the parties concerning the subject matter hereof. Neither party may assign this contract.

The parties have approved and executed this contract, Crutchto on the _____ day of _____, 2019 and City on the _____ day of _____, 2019.

CRUTCHO PUBLIC SCHOOLS OF OKLAHOMA
COUNTY, OKLAHOMA

ANTONIA JENNINGS, Board President

ATTEST:

JAMES ERIKA, Board Secretary

CITY OF MIDWEST CITY, a municipal
corporation

MATHEW D. DUKES, II Mayor

ATTEST:

SARA HANCOCK, City Clerk

APPROVED as to form and legality this _____ day of _____, 2019.

HEATHER POOLE, City Attorney



The City of
MIDWEST CITY
COMMUNITY DEVELOPMENT DEPARTMENT

Billy Harless, Community Development Director

ENGINEERING DIVISION
Patrick Menefee, City Engineer
CURRENT PLANNING DIVISION
Kellie Gilles, Planning Manager
COMPREHENSIVE PLANNING
Petya Stefanoff, Comprehensive Planner
BUILDING INSPECTION DIVISION
Christine Brakefield, Building Official
GIS DIVISION
Greg Hakman, GIS Coordinator

To: Honorable Mayor and City Council

From: Billy Harless, Community Development Director

Date: May 14, 2019

Subject: Discussion and consideration declaring the following items as surplus: (2) Vacuums; (1) Storage Cabinet; (2) Storage Drawers; (7) Light Fixtures; (1) Air Compressor; (2) Full Length Mirrors; (6) Lobby Chairs; (4) Flush Mount Stainless Paper Towel Dispensers; (5) Toilet Paper Holders Stainless; (4) Soap Dispensers Stainless, and authorizing their disposal by public auction, sealed bid, or destruction, if necessary.

This agenda item will declare the items below as surplus.

<u>Quantity</u>	<u>Description</u>
2	Vacuums (non-working)
1	Storage Cabinet - 3 drawers
2	Storage Drawer - card file type
1	Light Fixture - 2' x 2' Fluorescent
6	Light Fixtures - 2' x 4' Fluorescent
1	Air Compressor (non-working)
2	Full length mirrors
6	Lobby Chairs
4	Flush Mount Stainless Paper Towel Dispensers (New in Box)
5	Toilet Paper Holders Stainless (New in Box)
4	Soap Dispensers Stainless (New in Box)

Staff recommends approval.

Billy Harless, AICP
Community Development Director

BH/lkb



City of Midwest City Police Department

100 N. Midwest Boulevard

Midwest City, OK 73110

Office 405.739.1320

Fax 405.739.1398

Memorandum

TO: Honorable Mayor and City Council

FROM: Brandon Clabes, Chief of Police

DATE: May 14, 2019

SUBJECT: Discussion and consideration of declaring (1) 2008 Chevrolet 2500 Animal Welfare Truck and (1) 2006 Simulated Impaired Driving Experience, as surplus and authorizing their disposal by public auction, sealed bid or destruction, if necessary.

The items identified are property that the Midwest City Police Department no longer needs or uses and have been removed from service. Staff recommends that these items be declared surplus and be disposed of by public auction, sealed bid or destruction, if necessary.

Items for surplus:

2008 Chevrolet 2500 Animal Welfare Truck, VIN 1GCHK24K78E100292, Fleet Unit# 140233

2006 SIDNE 5.0 Elect Car, Serial #10603-0139 (Simulated Impaired Driving Experience)

Auction services are provided to the City by:

1. www.ebay.com
2. www.govdeals.com
3. www.pulicsurplus.com
- 4.

Staff recommends approval.

Brandon Clabes, Chief of Police



Public Works Administration
Vaughn Sullivan, Director
vsullivan@midwestcityok.org
R. Paul Streets, Assistant Director
rstreets@midwestcityok.org
8730 S.E. 15th Street,
Midwest City, Oklahoma 73110
O: 405-739-1060 /Fax: 405-739-1090

Memorandum

To: Honorable Mayor and Council

From: Vaughn K. Sullivan, Public Works Director

Date: May 14, 2019

Subject: Discussion and consideration of declaring the following equipment from Street Department: (2) Stihl weed eaters, (2) Stihl back pack blowers, (1) Stihl blower vacuum, and (1) Stihl chain saw, as surplus and authorizing their disposal by sealed bid, public auction, or by other means as necessary.

The equipment listed has been removed from service. There are no other operational applications available within the City.

Items for surplus:

<u>Description</u>	<u>Serial Number</u>	<u>Equipment Number</u>
Stihl Weed Eater	N/A	09-07-35
Stihl Weed Eater	N/A	09-07-117
Stihl Back Pack Blower	N/A	09-07-90
Stihl Back Pack Blower	N/A	09-07-100
Stihl Blower Vacuum	513350549	09-07-31
Stihl Chain Saw	N/A	N/A

Staff recommends approval.

Vaughn K. Sullivan
Public Works Director



Emergency Management

100 N. Midwest Boulevard

Midwest City, OK 73110

office 405.739.1386

TO: Honorable Mayor and Council

From: Mike Bower, Emergency Manager

Date: May 14, 2019

Subject: Discussion and consideration of declaring surplus (8) Whelen Vortex 1 sirens and (2) Whelen Vortex R4 sirens and putting them up for public auction, sealed bid or destruction, if necessary.

The above mentioned equipment is being replaced and removed from service on or before May 13, 2019. Installation is currently underway for ten (10) Whelen 2910 sirens that were purchased with funds provided from the August 2018 bond election and a grant from Oklahoma Office of Emergency Management.

A handwritten signature in black ink that reads "Mike Bower". The signature is written in a cursive style and is positioned above a horizontal line.

Mike Bower, Emergency Manager



DISCUSSION ITEMS





The City of
MIDWEST CITY
COMMUNITY DEVELOPMENT DEPARTMENT

Billy Harless, Community Development Director

ENGINEERING DIVISION
Patrick Menefee, City Engineer
CURRENT PLANNING DIVISION
Kellie Gilles, Manager
COMPREHENSIVE PLANNING
Petya Stefanoff, Comprehensive Planner
BUILDING INSPECTION DIVISION
Christine Brakefield, Building Official
GIS DIVISION
Greg Hakman, GIS Coordinator

To: Honorable Mayor and City Council

From: Billy Harless, Community Development Director

Date: May 14, 2019

Subject: (PC – 1990) Discussion and consideration of approval of the proposed preliminary plat of Cassidy Cove Section III, described as a part of the NW/4 of Section 1, T11N, R2W, located at 500 and 600 Davidson Road. (Continued from April 23, 2019 Council meeting.)

After careful consideration and discussion with Tim Johnson of Johnson and Associates, the City's consulting engineer for drainage requirements, we are requesting this item be continued until the May 28th regularly scheduled Council Meeting. This would give the City's consulting engineer, Johnson and Associates, a chance to complete a field review and analysis of the private and public drainage facilities and determine downstream system inadequacies as outlined in the attached letter from Mr. Johnson.

Action Required: Action is at the discretion of the Council.

Billy Harless, AICP
Community Development Director

May 6, 2019

City of Midwest City
100 N. Midwest Boulevard
Midwest City, OK 73110

Attention: Mr. Patrick Menefee, P.E, City Engineer

**RE: CASSIDY COVE SECTION 3
Detention Pond Review, Second Check, Updated April 30, 2019**

Dear Mr. Menefee:

Johnson & Associates (J&A) has completed the second review of the proposed storm water detention facility for Cassidy Cove Section 3. The review focused solely on the drainage report submitted for the detention pond. No construction plans were provided. No other plans or reports for any other site construction were provided for review at this time.

If constructed as discussed in the drainage report, the detention facility will provide adequate storage volume and sufficient flow attenuation to satisfy the Midwest City detention requirement for the 100-year frequency storm event.

However, the following comments are provided for consideration:

1. The detention facility will not function as proposed unless sufficient and adequate storm water drainage facilities are constructed to collect and convey the 100-year runoff for the entire 142.75 acres of onsite and surrounding drainage area into the detention pond. No drainage plans have been reviewed. A full system drainage analysis should be submitted for review.
2. A storm sewer facility should be constructed to collect and convey storm runoff from the west end of S.E 6th Street, westerly into the detention facility, to eliminate surface flow across Lots 13 and 14, Block 1, of the plat.
3. Construction of improvements within the plat will disturb a drainage swale identified as a "blue line" on the USGS Quad Map of the area. This line generally indicates an area of Waters of the United States which is regulated by the Tulsa District Corps of Engineers (COE) under Section 404 of the Clean Water Act. The COE should be contacted in request of possibly a Nationwide Permit 29 or 43 for approval of the proposed construction. Summary sheets of these permits are attached for review as well as a local USGS map exhibit.

4. Should the detention pond outlet be constructed with the release as proposed, there will be a dramatic impact, due to velocity, on the existing streams and channels, downstream of the project. Review of the conditions of this existing stream indicate that it is unimproved and in a natural state, with homes near and potentially in the backwater of the stream. Some consideration should be given to mitigate the much higher velocities that will be released from the proposed detention pond.

5. Although the development will not increase the magnitude of the flow rate leaving the site, consideration should be given to addressing concerns mentioned in the last public hearing and noted by staff. J&A would request that the applicant consider continuing this item until the next meeting so a field review and analysis of the Private and Public drainage facilities can be completed to determine downstream system inadequacies. Even though the pond meets and exceeds the City's design criteria there is a perceived concern by downstream neighbors. This is something that the staff can use to explain the current conditions to elected officials and concerned citizens.

Johnson & Associates staff is available for any discussion needed. If any additional information is needed, please contact this office at 405-235-8075.

Respectfully submitted,

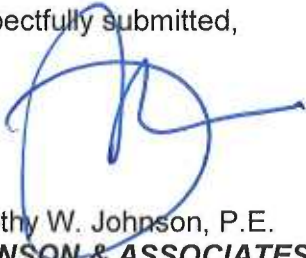

Timothy W. Johnson, P.E.
JOHNSON & ASSOCIATES, INC.

TWJ/dh

Attachment(s): USGS Map, Plat, Drainage Map, Summary NWP 29 and 43

cc: 4001-000/C

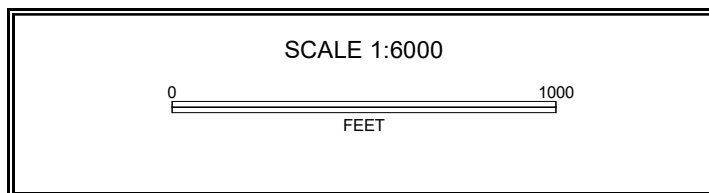

LOCATIONS:



NOT TO SCALE

PROJECT:

CASSIDY COVE

MIDWEST CITY, OKLAHOMA

PROJECT NUMBER: 19013
 DRAINAGE DATE: 02.25.19
 ISSUE DATE: 02.25.19

SEAL:

SUBMITTAL:

PRELIMINARY PLAT
 SUBMITTAL

REVISIONS:

NO.	DATE	DESCRIPTION

THIS DRAWING OR CONTENTS ARE NOT TO BE REPRODUCED, COPIED, OR TRANSMITTED IN ANY FORM OR BY ANY MEANS, ELECTRONIC OR MECHANICAL, INCLUDING PHOTOCOPYING, RECORDING, OR BY ANY INFORMATION STORAGE AND RETRIEVAL SYSTEM, WITHOUT THE WRITTEN PERMISSION OF CEDAR CREEK. CONSULT THE PROJECT CONTRACT FOR A COMPLETE LIST OF CONDITIONS OF USE. ANY VIOLATION OF THESE CONDITIONS WILL BE CONSIDERED A BREACH OF CONTRACT AND WILL BE SUBJECT TO LEGAL ACTION.

DRAWING TITLE:

OVERALL DRAINAGE MAP

SHEET:

DA1

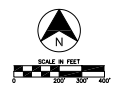
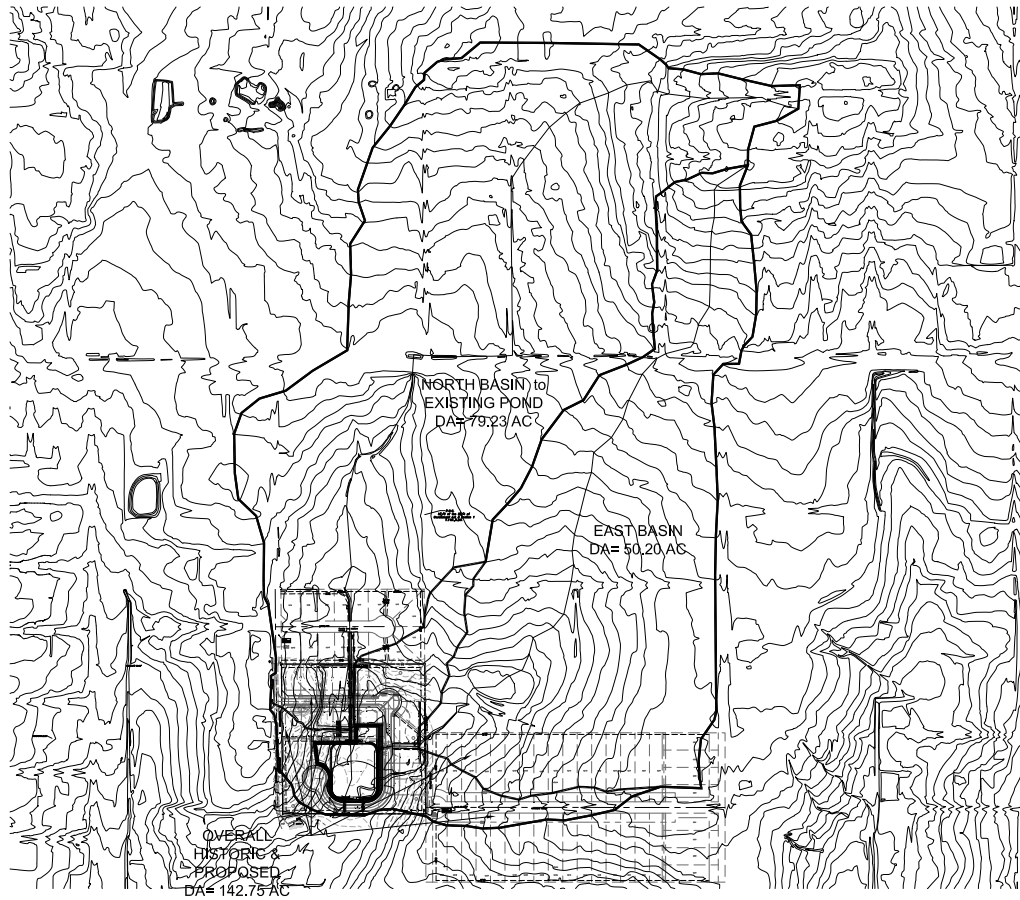

PRELIMINARY PLAT OF CASSIDY COVE SECTION 3

A PART OF THE NW/4 OF SECTION 01, T11N, R2W, I.M.
MIDWEST CITY, OKLAHOMA COUNTY, OKLAHOMA

LEGAL DESCRIPTION:
PART OF THE NORTHWEST QUARTER (NW/4) OF SECTION ONE (1), TOWNSHIP ELEVEN (1) NORTH, RANGE TWO (2) WEST OF THE MERIDIAN, MIDWEST CITY, OKLAHOMA COUNTY, OKLAHOMA, BEING MORE PARTICULARLY DESCRIBED AS FOLLOWS:
COMMENCING AT THE NORTHEAST CORNER OF THE SOUTHEAST QUARTER (SE/4) OF GOVERNMENT LOT THREE (3) OF SAID SECTION ONE (1), THENCE S07°02'00" E ALONG THE EAST LINE OF THE NORTHWEST QUARTER (NW/4) OF SAID SECTION ONE (1) A DISTANCE OF 663.3 FEET TO THE POINT OF BEGINNING;
THENCE CONTINUING S07°02'00" E ALONG THE EAST LINE OF THE NORTHWEST QUARTER (NW/4) OF SAID SECTION ONE (1), A DISTANCE OF 326.20 FEET; THENCE N07°59'52" W A DISTANCE OF 50.67 FEET TO A POINT 50.67 FEET EAST OF THE WEST LINE OF THE SOUTHEAST QUARTER (SE/4) OF GOVERNMENT LOT 3; THENCE N07°59'52" W A DISTANCE OF 50.67 FEET EAST OF AND PARALLEL WITH THE WEST LINE OF THE SOUTHEAST QUARTER (SE/4) OF GOVERNMENT LOT THREE (3) A DISTANCE OF 50.67 FEET;
THENCE S89°32'36" E A DISTANCE OF 63.83 TO THE POINT OF BEGINNING.

AND:
THE SOUTH HALF (S/2) OF THE SOUTHEAST QUARTER (SE/4) OF LOT THREE (3) OF SECTION ONE (1), TOWNSHIP ELEVEN (1) NORTH, RANGE TWO (2) WEST OF THE MERIDIAN, OKLAHOMA COUNTY, OKLAHOMA, AS SHOWN BY THE GOVERNMENT PLAT THEREOF,
CONTAINING 425.13576 SQUARE FEET OR 9.76 ACRES, MORE OR LESS.

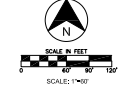
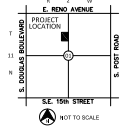

BASE OF BEARING: AN ASSUMED BEARING OF N42°30'19" AS THE WEST LINE OF SE/4 OF GOVERNMENT LOT 3, PER STATE PLATE GRIDS.

OWNER/DEVELOPER:
JCH DEVELOPMENT LLC
P.O. BOX 3078
MIDWEST CITY, OK 73140
405-594-9500

SURVEYOR:
GOLDEN LAND SURVEYING
300 N.W. 107TH AVENUE
OKLAHOMA CITY, OK 73133
405-620-7100

ENGINEER:
CEDAR CREEK ENGINEERING
P.O. BOX 1624
OKLAHOMA CITY, OK 73113
405-776-2388

LEGEND	
---	BOUNDARY LINE
---	RIGHT OF WAY LINE
---	EASEMENT LINE
---	EXISTING CONCRETE CURBS AND GUTTER
---	PROPOSED CONCRETE CURBS AND GUTTER
---	PROPOSED FIRE LANE STRIPING
---	OVERHEAD ELECTRIC
---	UNDERGROUND ELECTRIC
---	GAS LINE
---	UNDERGROUND TELEPHONE
---	UNDERGROUND FIBER OPTIC
---	SEWER MAIN
---	WATERLINE
---	BENCHMARK
+	FIRE HYDRANT
+	WATER VALVE
+	EX. WATER METER PIT
+	EX. WATER METER
+	PROP. WATER METER
+	EX. SPRINKLER VALVE
+	EX. AUTO SPRINKLER
+	EX. ELECT. PEDESTAL
+	EX. ELECT. TRANSFORMER
+	EX. ELECT. METER
+	PROP. ELECT. METER
+	EX. AIR CONDITIONER
+	EX. SIGNAGE
+	EX. LIGHT POLE
+	PROP. LIGHT POLE
+	EX. ISOLAND
+	PROP. INLETS (SEE GRADING PLAN FOR TYPE)
+	VERTICAL SEPARATION REQUIREMENT
+	EX. POWER POLE
+	PROP. POWER POLE
+	EX. TELEPHONE PIGTAIL
+	EX. TELEPHONE MANHOLE
+	EX. TRAFFIC SIGNAL LIGHT
+	EX. TRAFFIC CONTROL BOX
+	EX. FLAG POLE
+	EX. YARD LIGHT
+	EX. GREASE TRAP
+	EX. SS MANHOLE
+	PROP. SS MANHOLE
+	EX. GAS METER
+	PROP. GAS METER
+	EX. ELECT. MANHOLE
+	EX. STORM MANHOLE

CURVE TABLE (CENTERLINE)					
CURVE #	LENGTH	RADIUS	DELTA	CHORD DIRECTION	CHORD LENGTH
C1	157.26'	100.00	N 00°08'16" W	N 45°01'50" E	141.55'
C2	156.11'	100.00	N 00°33'27" E	N 45°11'45" W	140.73'

CURVE TABLE (LOTS)					
CURVE #	LENGTH	RADIUS	DELTA	CHORD DIRECTION	CHORD LENGTH
C1	3.56'	25.00	N 81°50'57" E	S 44°05'34" W	3.55'
C2	17.47'	25.00	N 49°57'40" E	S 19°59'52" W	17.12'

LINE TABLE (CENTERLINE)		
LINE #	LENGTH	DIRECTION
L1	25.00'	N 89°31'31" E
L2	31.46'	S 00°28'20" E

LINE TABLE (LOTS)		
LINE #	LENGTH	DIRECTION
L1	35.49'	S 45°14'53" E
L2	35.22'	N 44°46'7" E
L3	35.36"	S 45°01'18" E

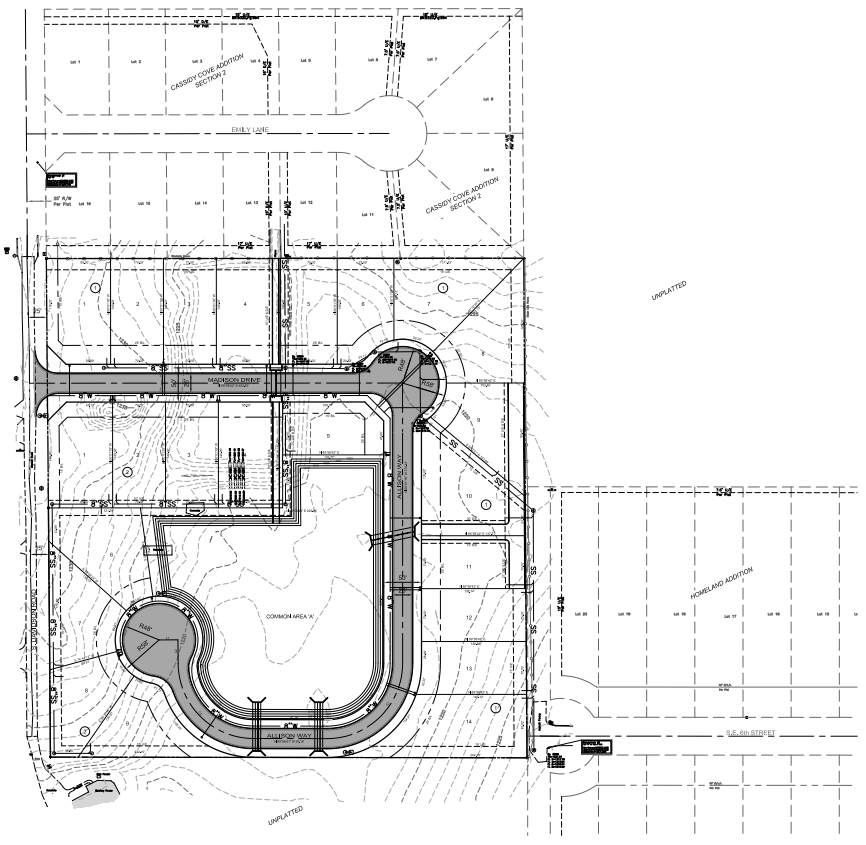

Nationwide Permit 29 - Residential Developments

Effective Date: March 19, 2017; Expiration Date: March 18, 2022
(NWP Final Notice, 82 FR 1860)

Nationwide Permit 29 - Residential Developments. Discharges of dredged or fill material into non-tidal waters of the United States for the construction or expansion of a single residence, a multiple unit residential development, or a residential subdivision. This NWP authorizes the construction of building foundations and building pads and attendant features that are necessary for the use of the residence or residential development. Attendant features may include but are not limited to roads, parking lots, garages, yards, utility lines, storm water management facilities, septic fields, and recreation facilities such as playgrounds, playing fields, and golf courses (provided the golf course is an integral part of the residential development).

The discharge must not cause the loss of greater than 1/2-acre of non-tidal waters of the United States. The discharge must not cause the loss of more than 300 linear feet of stream bed, unless for intermittent and ephemeral stream beds the district engineer waives the 300 linear foot limit by making a written determination concluding that the discharge will result in no more than minimal adverse environmental effects. This NWP does not authorize discharges into non-tidal wetlands adjacent to tidal waters. The loss of stream bed plus any other losses of jurisdictional wetlands and waters caused by the NWP activity cannot exceed 1/2-acre.

Subdivisions: For residential subdivisions, the aggregate total loss of waters of United States authorized by this NWP cannot exceed 1/2-acre. This includes any loss of waters of the United States associated with development of individual subdivision lots.

Notification: The permittee must submit a pre-construction notification to the district engineer prior to commencing the activity. (See general condition 32.) (Authorities: Sections 10 and 404)

A. Nationwide Permit General Conditions

Note: To qualify for NWP authorization, the prospective permittee must comply with the following general conditions, as applicable, in addition to any regional or case-specific conditions imposed by the division engineer or district engineer. Prospective permittees should contact the appropriate Corps district office to determine if regional conditions have been imposed on an NWP. Prospective permittees should also contact the appropriate Corps district office to determine the status of Clean Water Act Section 401 water quality certification and/ or Coastal Zone Management Act consistency for an NWP. Every person who may wish to obtain permit authorization under one or more NWPs, or who is currently relying on an existing or prior permit authorization under one or more NWPs, has been and is on notice that all of the provisions of 33 CFR 330.1 through 330.6 apply to every NWP authorization. Note especially 33 CFR 330.5 relating to the modification, suspension, or revocation of any NWP authorization.

1. **Navigation.** (a) No activity may cause more than a minimal adverse effect on navigation. (b) Any safety lights and signals prescribed by the U.S. Coast Guard, through regulations or otherwise, must be installed and maintained at the permittee's expense on authorized facilities in navigable waters of the United States. (c) The permittee understands and agrees that, if future operations by the United States require the removal, relocation, or other alteration, of the structure or work herein authorized, or if, in the opinion of the Secretary of the Army or his authorized representative, said structure or work shall cause unreasonable obstruction to the free navigation of the navigable waters, the permittee will be required, upon due notice from the Corps of Engineers, to remove, relocate, or alter the structural work or obstructions caused thereby, without expense to the United States. No claim shall be made against the United States on account of any such removal or alteration.

2. **Aquatic Life Movements.** No activity may substantially disrupt the necessary life cycle movements of those species of aquatic life indigenous to the waterbody, including those species that normally migrate through the area, unless the activity's primary purpose is to impound water. All permanent and temporary crossings of

Nationwide Permit 43 - Stormwater Management Facilities
Effective Date: March 19, 2017; Expiration Date: March 18, 2022
(NWP Final Notice, 82 FR 1860)

Nationwide Permit 43 - Stormwater Management Facilities. Discharges of dredged or fill material into non-tidal waters of the United States for the construction of stormwater management facilities, including stormwater detention basins and retention basins and other stormwater management facilities; the construction of water control structures, outfall structures and emergency spillways; the construction of low impact development integrated management features such as bioretention facilities (e.g., rain gardens), vegetated filter strips, grassed swales, and infiltration trenches; and the construction of pollutant reduction green infrastructure features designed to reduce inputs of sediments, nutrients, and other pollutants into waters to meet reduction targets established under Total Daily Maximum Loads set under the Clean Water Act.

This NWP authorizes, to the extent that a section 404 permit is required, discharges of dredged or fill material into non-tidal waters of the United States for the maintenance of stormwater management facilities, low impact development integrated management features, and pollutant reduction green infrastructure features. The maintenance of stormwater management facilities, low impact development integrated management features, and pollutant reduction green infrastructure features that are not waters of the United States does not require a section 404 permit.

The discharge must not cause the loss of greater than 1/2-acre of non-tidal waters of the United States. The discharge must not cause the loss of more than 300 linear feet of stream bed, unless for intermittent and ephemeral stream beds the district engineer waives the 300 linear foot limit by making a written determination concluding that the discharge will result in no more than minimal adverse environmental effects. This NWP does not authorize discharges into non-tidal wetlands adjacent to tidal waters. The loss of stream bed plus any other losses of jurisdictional wetlands and waters caused by the NWP activity cannot exceed 1/2-acre. This NWP does not authorize discharges of dredged or fill material for the construction of new stormwater management facilities in perennial streams.

Notification: For discharges into non-tidal waters of the United States for the construction of new stormwater management facilities or pollutant reduction green infrastructure features, or the expansion of existing stormwater management facilities or pollutant reduction green infrastructure features, the permittee must submit a pre-construction notification to the district engineer prior to commencing the activity. (See general condition 32.) Maintenance activities do not require pre-construction notification if they are limited to restoring the original design capacities of the stormwater management facility or pollutant reduction green infrastructure feature. (Authority: Section 404)

A. Nationwide Permit General Conditions

Note: To qualify for NWP authorization, the prospective permittee must comply with the following general conditions, as applicable, in addition to any regional or case-specific conditions imposed by the division engineer or district engineer. Prospective permittees should contact the appropriate Corps district office to determine if regional conditions have been imposed on an NWP. Prospective permittees should also contact the appropriate Corps district office to determine the status of Clean Water Act Section 401 water quality certification and/ or Coastal Zone Management Act consistency for an NWP. Every person who may wish to obtain permit authorization under one or more NWPs, or who is currently relying on an existing or prior permit authorization under one or more NWPs, has been and is on notice that all of the provisions of 33 CFR 330.1 through 330.6 apply to every NWP authorization. Note especially 33 CFR 330.5 relating to the modification, suspension, or revocation of any NWP authorization.

1. **Navigation.** (a) No activity may cause more than a minimal adverse effect on navigation. (b) Any safety lights and signals prescribed by the U.S. Coast Guard, through regulations or otherwise, must be installed and



The City of
MIDWEST CITY
 COMMUNITY DEVELOPMENT DEPARTMENT

Billy Harless, Community Development Director

ENGINEERING DIVISION
 Patrick Menefee, City Engineer
 CURRENT PLANNING DIVISION
 Kellie Gilles, Manager
 COMPREHENSIVE PLANNING
 Petya Stefanoff, Comprehensive Planner
 BUILDING INSPECTION DIVISION
 Christine Brakefield, Building Official
 GIS DIVISION
 Greg Hakman, GIS Coordinator

To: Honorable Mayor and City Council

From: Billy Harless, Community Development Director

Date: April 23, 2019

Subject: (PC – 1990) Discussion and consideration of approval of the proposed preliminary plat of Cassidy Cove Section III, described as a part of the NW/4 of Section 1, T11N, R2W, located at 500 and 600 Davidson Road.

Executive Summary: This item is a request to subdivide a single parcel into twenty-five (25) individual parcels for single family development. Access to the subdivision will be via Davidson Road. The applicant is proposing water and sewer line extensions to serve all of the lots. The area of request is currently zoned R-6, Single Family Detached Residential. No variances to any of the requirements of the Zoning Ordinance for development in the R-6 district will be allowed within this development. The Park Land Review Committee recommended approval of a fee to be paid in lieu of park land dedication. Tree preservation will be required with this subdivision. The applicant has requested a waiver to the prohibition of lots backing onto a local street as two lots and a

small portion of another lot back onto Davidson Road. Staff recommends approval of the Cassidy Cove Section III Preliminary Plat and the requested waiver.



Dates of Hearing: Planning Commission – April 2, 2019
 City Council – April 23, 2019

Council Ward: Ward 2, Pat Byrne

Owner/Applicant: Jim Campbell

Engineer: Jon Doyle, Cedar Creek

Proposed Use: Twenty-five (25) single family residential lots

Size:

The area of request has a frontage along Davidson Road of approximately 660 ft. and contains an area of approximately 9.76 acres.

Zoning Districts:

Area of Request – R-6, Single Family Detached Residential
North, South, East and West – R-6, Single Family Detached Residential

Land Use:

Area of Request – vacant
North, South and East – single family residences

Municipal Code Citation:

2.7.1. R-6, Single –Family Detached Residential District

The R-6, Single-Family Detached Residential District is intended for single-family residences on lots of not less than 6,000 square feet in size. This district is estimated to yield a maximum density of 5.1 gross dwelling units per acre (DUA). Additional uses for the district shall include churches, schools and public parks in logical neighborhood units.

38-18.1. Purpose

The purpose of a Preliminary Plat shall be to determine the general layout of the subdivision, the adequacy of public facilities needed to serve the intended development, and the overall compliance of the land division with applicable requirements of the Subdivision Ordinance.

History:

1. This area has been zoned single-family residential since the adoption of the 1985 zoning code and has never been platted.
2. The Planning Commission recommended approval of this item subject to staff comments on April 2, 2019.

Engineer's Comments:

Section 38-18 in the Subdivision Regulations requires all existing and proposed utility lines and public improvements be reflected on the preliminary plat and submitted on a preliminary utility site plan. Note that the proposed public utility line installations required with this application are shown on the plat, must be constructed and will be dedicated to the city prior to the final plat application.

Water Supply and Distribution

An eight (8) inch public water main is located in the west right of way of Davidson Road extending to the northwest corner of the area of request.

The applicant has proposed the extension of that public water main south and east, bisecting the site, providing service to all of the proposed lots.

Extension of the water supply to serve this property is required as outlined in Municipal Code 43-32.

Connection to the public water supply system for domestic service is a building permit requirement per Municipal Code 43-32 for all new buildings.

Sanitary Sewer Collection and Disposal

An eight (8) inch public sewer main is located in a dedicated utility easement extending along the east side of the area of request. Also, an eight (8) inch public sewer main is located in a dedicated utility easement that passes through the northern half of the area of request.

The applicant has proposed constructing a public sewer main south, bisecting the site, providing service to all of the proposed lots.

Connection to the public sanitary sewer system for domestic service is a building permit requirement per Municipal Code Chapter 43-109 for all lots.

Streets and Sidewalks

Access to the area of request is available from Davidson Road. Davidson Road is classified as a local street in the 2008 Comprehensive Plan. Davidson Road is a two (2) lane, 20-foot wide, uncurbed, asphalt concrete roadway. Current code requires a total, half street right-of-way width from center line of twenty five (25) feet for local roads and presently, Davidson Road has twenty five (25) feet of right-of-way adjacent to and parallel to the west side of the area of request.

Right of way grants to the city are not required with this application.

Davidson Road is uncurbed and does not meet city's standards for a local street. As per Section 38-45, half street improvements along the frontage of Davidson Road will be completed prior to the final plat application. The applicant proposes to construct a public local street, Allison Way, with sidewalks to service the area of request.

Improvement plans for the street and sidewalks must be prepared by a registered professional engineer and be submitted to staff for plan review and approval.

The comprehensive plan dictates the connection of internal streets within the square mile sections that are designated as future collector roads. The thoroughfare plan does not designate Davidson Road or S.E. 6th Street as potential collector roads in the plan. The subdivision plan also requires the connection of roads in a proposed subdivision if the proposal contains fifty or more proposed lots. This application falls below that threshold at twenty five lots. The applicant proposes to construct a public local street that is a cul de sac with one point of ingress / egress. A midpoint bulb out is also proposed to benefit fire engine maneuverability in the subdivision.

Drainage and Flood Control, Wetlands, and Sediment Control

Drainage to the area of request is from the north and the east, travelling to the south via both overland flow from the east and through a concrete channel from the north. Currently, the area of request is undeveloped.

The concrete channel from the north drains the previous Cassidy Cove subdivision. The drainage from the east is the S.E. 4th and S.E. 6th Street Additions and the undeveloped area adjacent to Saint Paul Avenue. These two runoffs combine on this property and make their way south to a concrete channel located in the Three Oaks Addition.

The applicant has proposed a large, high capacity detention pond that has multiple barrels releasing water into the same creek that drains to Three Oaks. The current creek runs at a flow rate of roughly 645 c.f.s. as is. The proposed detention improvement will reduce the runoff into the creek to 583 c.f.s. The accompanying drainage map shows the improvement would reduce the flow rate to Three Oaks Addition by approximately 10%.

The proposed detention facility will be built at the meeting point of the two creeks entering the proposed subdivision. This creates the opportunity to slow down water at the point it is currently combining to continue south to Three Oaks. It is an optimal point to achieve a slowdown of the creeks. The pond will be a benefit to the area's drainage.

The area of request is not affected by flood zone AE (the 100-year floodplain) as shown on the effective Flood Insurance Rate Map (FIRM) number 40109C0330H, dated December 12, 2009.

No identified wetlands are located on or abutting the area of request as shown on the Choctaw quadrangle of the 1989 National Wetlands Inventory map as prepared by the United States Department of the Interior Fish and Wildlife Service.

All future development on the proposed tracts must conform to the applicable requirements of Municipal Code Chapter 13, "Drainage and Flood Control."

Resolution 84-20 requires that developers install and maintain sediment and/or erosion controls in conjunction with their construction activities. Any proposed development must conform to the applicable requirements of Municipal Code Chapter 43, "Erosion Control." Sediment control plans must be submitted to and approved by the city before any land disturbance is done on-site. The developer is responsible for the cleanup of sediment and other debris from drainage pipes, ditches, streets and abutting properties as a result of his activities.

Easements and Right-of-Way

The required easements and existing right of way for the area of request are illustrated on the preliminary plat and will be dedicated to the city when the final plat is filed.

All easements and right of way dedications are to comply with Code Sections 38-41 and 38-44.

Fire Marshal's Comments:

The Fire Department has reviewed this preliminary plat. The property is required to meet and maintain the requirements of Midwest City Ordinances, Section 15.

Staff Comments:

The purpose of this preliminary plat is to create 25 single family residential lots. The area of request is zoned R-6, Single Family Detached Residential. If this proposed subdivision is approved, all development will be required to meet the regulations for the R-6 district as stated in the Zoning Ordinance. These regulations include:

- At least 70% of the dwelling units within the development must adhere to section 5.15 of the Zoning Ordinance pertaining to single-family driveways and garages
- The exterior of each home must be constructed of a minimum of 85% masonry materials, 100% facing the street
- 25' front setback, 20' rear setback, 7' side setbacks
- 40% maximum building coverage
- Minimum 5:12 roof pitch

One new curb-cut along Davidson Road will provide access to the area of request. As this subdivision is creating less than 50 lots, a secondary point of access is not required.

The Park Land Review Committee met on March 8, 2019 to review the proposed subdivision. As the subdivision is anticipated to generate far less than 2,500 new residents, the code does allow the applicant to pay a fee in lieu of a park land dedication. The applicant requested the fee in lieu option and the committee voted to approve the request. The fee will be determined by staff and the applicant as required by code and paid prior to application for the final plat.

Section 38-53.4 of the 2012 Midwest City Subdivision Regulations requires the applicant to submit a Tree Canopy Management Plan with the preliminary plat application. The applicant has provided this plan. The Subdivision Regulations allow developers to preserve trees with two (2) options. The first option is standard compliance wherein the applicant may only remove trees from proposed street right-of-ways, proposed utility easements and proposed areas for site features required by the Subdivision Regulations. The second option allows the developer to create a cluster development, preserving trees in designated open spaces. The applicant has chosen to pursue the first option, standard compliance. Under this requirement of the code, the applicant may only remove trees from the proposed right-of-ways, easements, and areas of site features. All other trees on the lot must remain through the entire platting process.

The applicant has requested a waiver to Section 38-48.6(B), Lot Orientation Restrictions which states that lots are prohibited from backing to Local Streets. In the design of this subdivision, lots 9, 10 and a small portion of lot 8, block 2 back onto Davidson Road, a local street. The applicant chose to move forward with this design to accommodate the necessary size of the detention area. Davidson Road is not a high traffic road and this particular portion of Davidson only provides access to two (2) residential properties and dead-ends at the end of this proposed subdivision. The applicant's letter requesting the waiver is included in this report. For these reasons, staff recommends approval of this request.

Since this preliminary plat meets the subdivision regulations, staff recommends approval of the preliminary plat of Cassidy Cove Section III subject to these comments.

April 23, 2019

Action Required: Approve or reject the preliminary plat of Cassidy Cove Section III located on the property as noted herein, subject to the staff comments and found in the April 23, 2019 agenda packet and made a part of PC- 1990 file.

A handwritten signature in black ink, appearing to read "Billy Harless". The signature is fluid and cursive, with a long horizontal stroke at the end.

Billy Harless, AICP
Community Development Director

KG

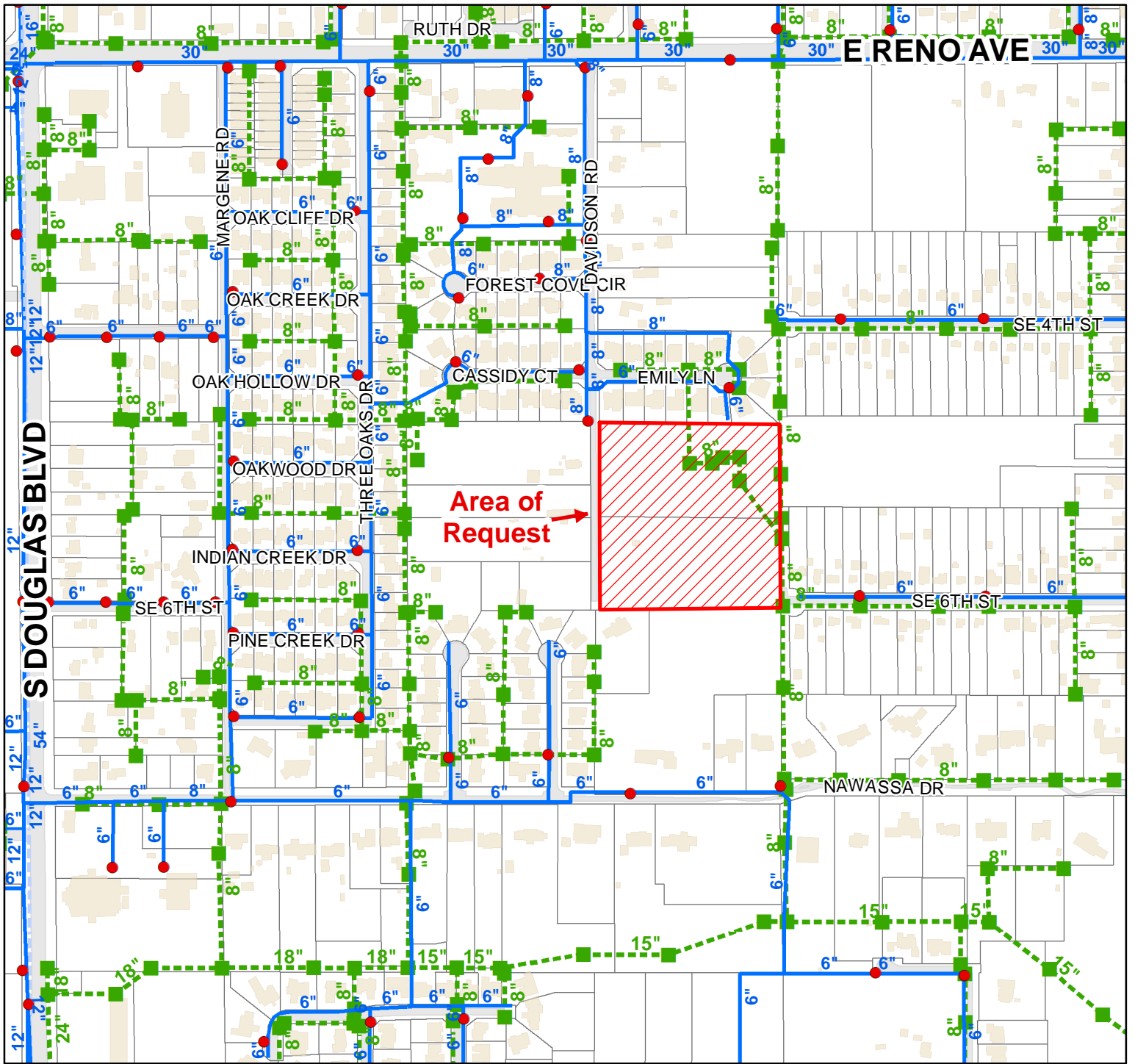

Locator Map

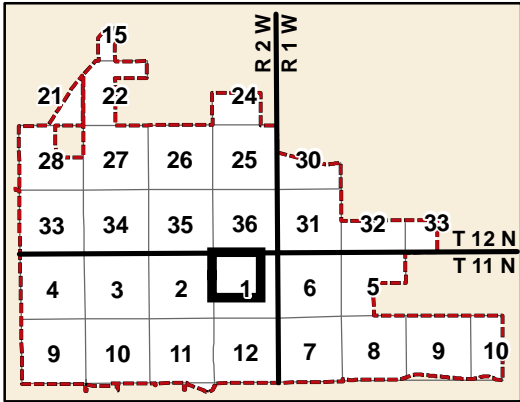

Water/Sewer Legend

- () Fire Hydrants
- Water Lines
 - Distribution
 - Well
 - - - OKC Cross Country
 - - - Sooner Utilities
 - - - Thunderbird
 - - - Unknown
- " Sewer Manholes
- - - Sewer Lines

**WATER/SEWER LINE
LOCATION MAP FOR
PC-1990
(NW/4, Sec. 1, T11N, R2W)**

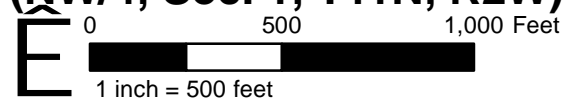

THIS MAP IS A GENERAL INFORMATION PUBLIC RESOURCE. THE CITY OF MIDWEST CITY MAKES NO WARRANTY, REPRESENTATION OR GUARANTEE AS TO THE CONTENT, ACCURACY, TIMELINESS OR COMPLETENESS OF ANY OF THE INFORMATION PROVIDED ON THIS MAP. ANY PARTY'S USE OR RELIANCE ON THIS MAP OR ANY INFORMATION ON IT IS AT THAT PARTY'S OWN RISK AND WITHOUT LIABILITY TO THE CITY OF MIDWEST CITY, ITS OFFICIALS OR ITS EMPLOYEES FOR ANY DISCREPANCIES, ERRORS OR VARIANCES THAT MAY EXIST.

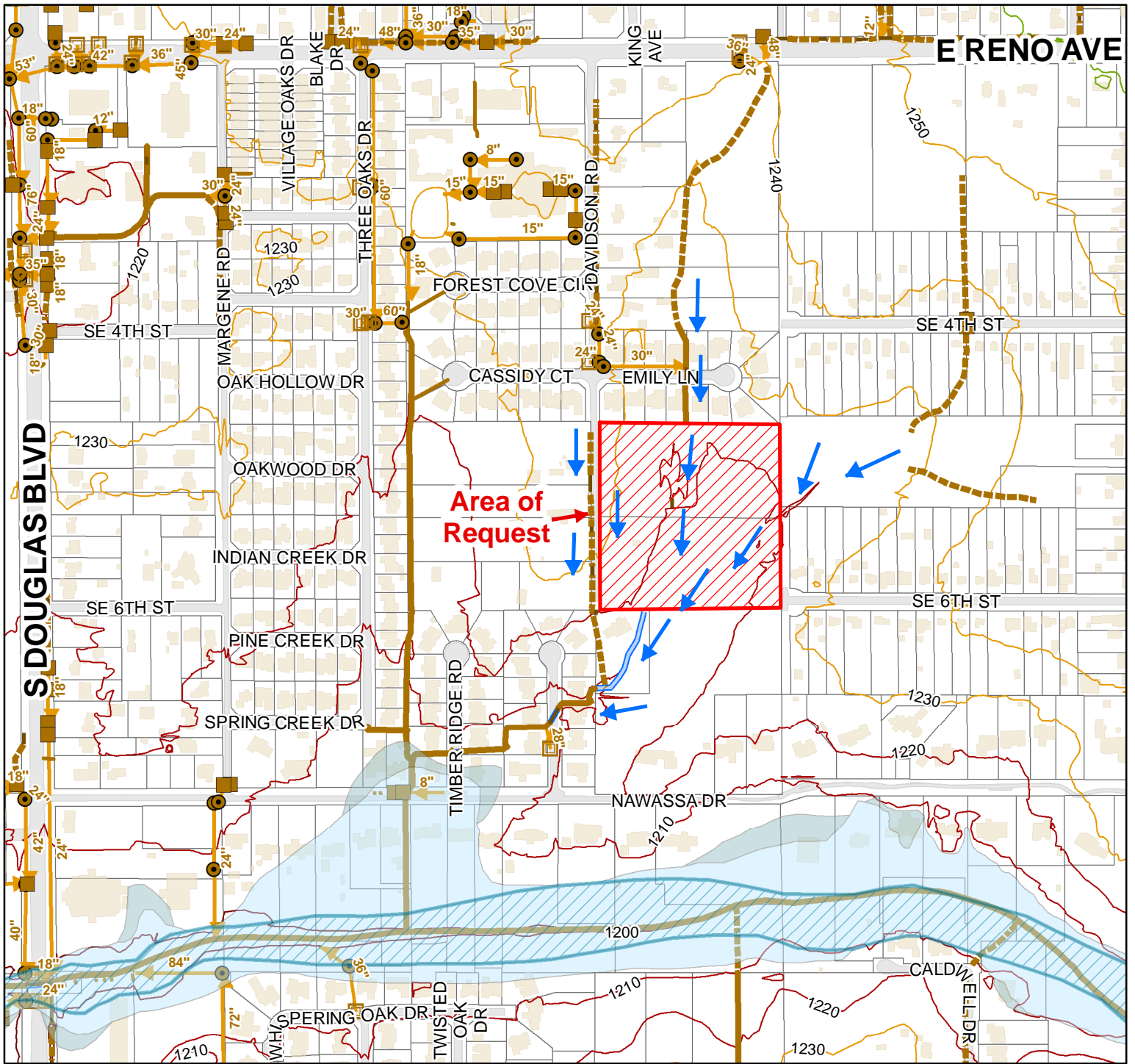

Locator Map

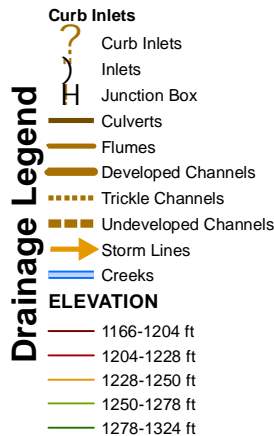
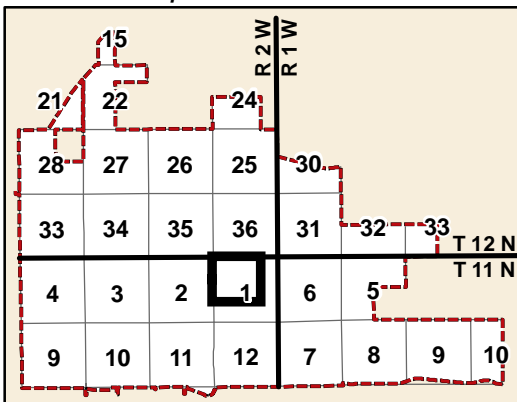

2009 FEMA Floodplains

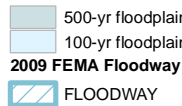

DRAINAGE LOCATION MAP FOR PC-1990

(NW/4, Sec. 1, T11N, R2W)



THIS MAP IS A GENERAL INFORMATION PUBLIC RESOURCE. THE CITY OF MIDWEST CITY MAKES NO WARRANTY, REPRESENTATION OR GUARANTEE AS TO THE CONTENT, ACCURACY, TIMELINESS OR COMPLETENESS OF ANY OF THE INFORMATION PROVIDED ON THIS MAP. ANY PARTY'S USE OR RELIANCE ON THIS MAP OR ANY INFORMATION ON IT IS AT THAT PARTY'S OWN RISK AND WITHOUT LIABILITY TO THE CITY OF MIDWEST CITY, ITS OFFICIALS OR ITS EMPLOYEES FOR ANY DISCREPANCIES, ERRORS OR VARIANCES THAT MAY EXIST.

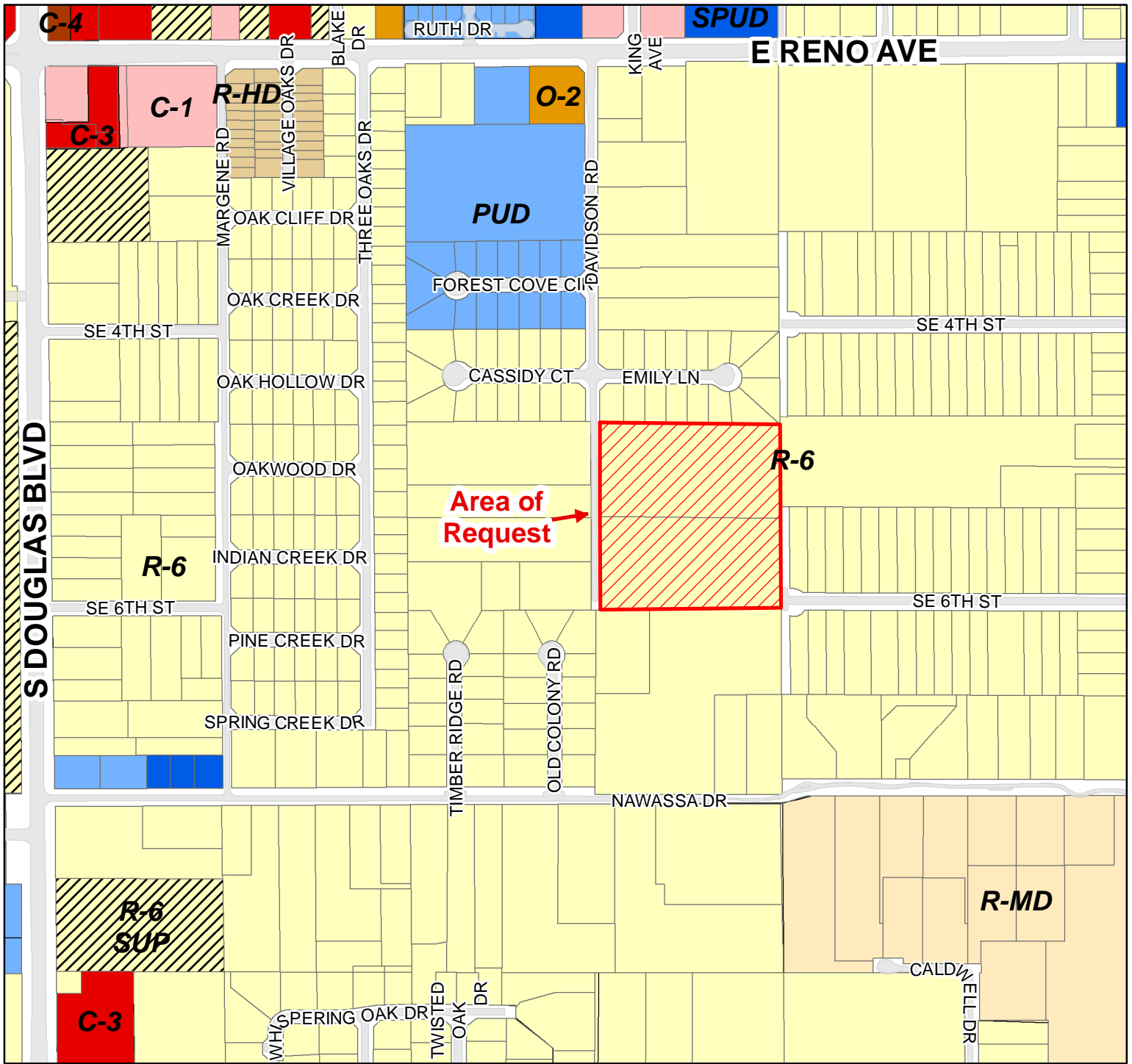

Locator Map

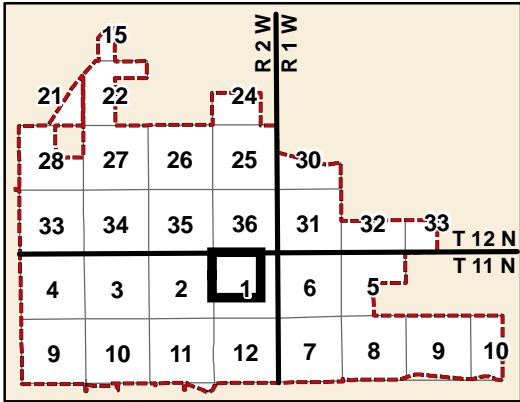

Current Zoning Legend

A-1	I-2 SUP	R-35
A-1 SUP	I-3	R-2F
C-1	O-1	R-MD
C-1 SUP	O-1 SUP	R-MD SUP
C-2	O-2	R-HD
C-3	O-2 SUP	R-HD SUP
C-3 SUP	R-6	R-MH-1
C-4	R-6 SUP	R-MH-2
C-4 SUP	R-8	PUD
I-1	R-10	SPUD
I-2	R-22	HOS
		HOS SUP

**ZONING MAP FOR
PC-1990
(NW/4, Sec. 1, T11N, R2W)**

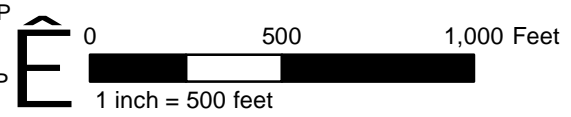

THIS MAP IS A GENERAL INFORMATION PUBLIC RESOURCE. THE CITY OF MIDWEST CITY MAKES NO WARRANTY, REPRESENTATION OR GUARANTEE AS TO THE CONTENT, ACCURACY, TIMELINESS OR COMPLETENESS OF ANY OF THE INFORMATION PROVIDED ON THIS MAP. ANY PARTY'S USE OR RELIANCE ON THIS MAP OR ANY INFORMATION ON IT IS AT THAT PARTY'S OWN RISK AND WITHOUT LIABILITY TO THE CITY OF MIDWEST CITY, ITS OFFICIALS OR ITS EMPLOYEES FOR ANY DISCREPANCIES, ERRORS OR VARIANCES THAT MAY EXIST.

JCH Development
P.O. Box 30706
Midwest City, OK 73130
Phone: 405.739.0760

March 13, 2019

City of Midwest City
100 N. Midwest Blvd.
Midwest City, OK 73110

RE: Request to waiver Section 38-48.6 (B)

To Whom it May Concern,

JCH Development requests a waiver of Section 38-48.6 (B) for the proposed Cassidy Cove, Section 3 Addition.

Section 38-48.6 (B) states that lots are prohibited from backing to local streets. This configuration is necessary to accommodate the size of the detention area. Only 2 lots outside of this proposed subdivision derive access from this part of Davidson. Only 2 lots back onto Davidson. Back fences will observe the same building line as Lot 1- Block 1, and Lot 1- Block 2 at the subdivision entry.

Thank you,

A handwritten signature in black ink, appearing to read "Jim Campbell", with a long, sweeping flourish extending to the right.

Jim Campbell
JCH Development

PRELIMINARY PLAT OF CASSIDY COVE SECTION 3

A PART OF THE NW/4 OF SECTION 01, T11N, R2W, I.M.
MIDWEST CITY, OKLAHOMA COUNTY, OKLAHOMA

LEGAL DESCRIPTION:
PART OF THE NORTHWEST QUARTER (NW/4) OF SECTION ONE (1), TOWNSHIP ELEVEN (11) NORTH, RANGE TWO (2) WEST OF THE INDIAN MERIDIAN, MIDWEST CITY, OKLAHOMA COUNTY, OKLAHOMA, BEING MORE PARTICULARLY DESCRIBED AS FOLLOWS:
COMMENCING AT THE NORTHEAST CORNER OF THE SOUTHEAST QUARTER (SE/4) OF GOVERNMENT LOT THREE (3) OF SAID SECTION ONE (1); THENCE S00°00'50"E ALONG THE EAST LINE OF THE NORTHWEST QUARTER (NW/4) OF SAID SECTION ONE (1), A DISTANCE OF 660.13 FEET TO THE POINT OF BEGINNING.
THENCE CONTINUING S00°00'50" E ALONG THE EAST LINE OF THE NORTHWEST QUARTER (NW/4) OF SAID SECTION ONE (1), A DISTANCE OF 328.50';
THENCE N89°36'28"W A DISTANCE OF 631.26' TO A POINT 25.00' EAST OF THE WEST LINE OF THE SOUTHEAST QUARTER (SE/4) OF GOVERNMENT LOT 3;
THENCE N00°06'47"W A DISTANCE OF 25.00 FEET EAST OF AND PARALLEL WITH THE WEST LINE OF THE SOUTHEAST QUARTER (SE/4) OF GOVERNMENT LOT THREE (3) A DISTANCE OF 329.93';
THENCE S89°39'36"E A DISTANCE OF 631.83' TO THE POINT OF BEGINNING.

AND

THE SOUTH HALF (S/2) OF THE SOUTHEAST QUARTER (SE/4) OF LOT THREE (3) OF SECTION ONE (1), TOWNSHIP ELEVEN (11) NORTH, RANGE TWO (2) WEST OF THE INDIAN MERIDIAN, OKLAHOMA COUNTY, OKLAHOMA, AS SHOWN BY THE GOVERNMENT PLAT THEREOF.

CONTAINING 425,135.76 SQUARE FEET OR 9.76 ACRES, MORE OR LESS.

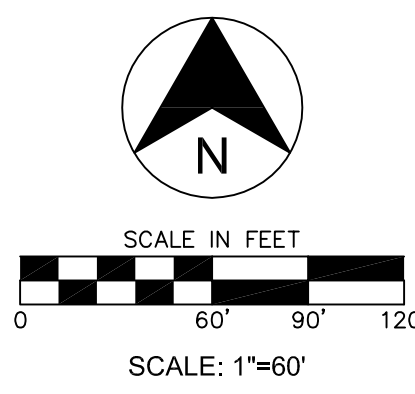
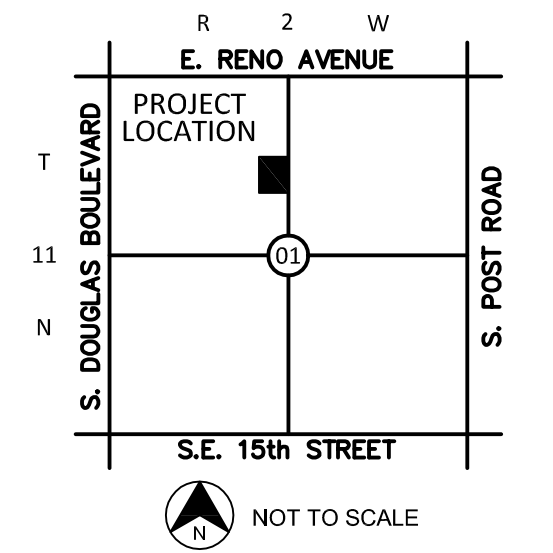

BASIS OF BEARING: AN ASSUMED BEARING OF N00°28'29" W AS THE WEST LINE OF SE/4 OF GOVERNMENT LOT 3, PER STATE PLANE GRID.

OWNER/SUBDIVIDER:
JCH DEVELOPMENT LLC
P.O. BOX 30706
MIDWEST CITY, OK 73140
405-739-0760

SURVEYOR:
GOLDEN LAND SURVEYING
920 N.W. 139TH PKWY
OKLAHOMA CITY, OK 73013
405-802-7883

ENGINEER:
CEDAR CREEK ENGINEERING
P.O. BOX 14534
OKLAHOMA CITY, OK 73113
405-778-3385

LEGEND

	BOUNDARY LINE		EX. POWER POLE
	RIGHT OF WAY LINE		PROP. POWER POLE
	EASEMENT LINE		EX. TELEPHONE PED.
	EXISTING CONCRETE CURB AND GUTTER		EX. TELEPHONE MANHOLE
	PROPOSED CONCRETE CURB AND GUTTER		PROP. WATER METER
	PROPOSED FIRE LANE STRIPING		EX. TRAFFIC SIGNAL LIGHT
	OVERHEAD ELECTRIC		EX. TRAFFIC CONTROL BOX
	UNDERGROUND ELECTRIC		EX. FLAG POLE
	GAS LINE		EX. YARD LIGHT
	UNDERGROUND TELEPHONE		EX. GREASE TRAP
	UNDERGROUND FIBER OPTIC		EX. ELECT. METER
	SANITARY SEWER		PROP. ELECT. METER
	WATERLINE		EX. AIR CONDITIONER
	BENCHMARK		EX. SIGNAGE
	FIRE HYDRANT		EX. LIGHT POLE
	WATER VALVE		PROP. LIGHT POLE
	EX. WATER METER PIT		EX. BOLLARD
	EX. WATER METER		PROP. INLETS (SEE GRADING PLAN FOR TYPE)
	EX. SPRINKLER VALVE		VERTICAL SEPARATION REQUIREMENT
	EX. AUTO SPRINKLER		
	EX. ELECT. PEDESTAL		
	EX. ELECT. TRANSFORMER		
	EX. ELECT. METER		
	PROP. ELECT. METER		
	EX. AIR CONDITIONER		
	EX. SIGNAGE		
	EX. LIGHT POLE		
	PROP. LIGHT POLE		
	EX. BOLLARD		

CURVE #	LENGTH	RADIUS	DELTA	CHORD DIRECTION	CHORD LENGTH
C1	157.26'	100.00	N 00°06'16" W	N 45°01'50" E	141.55'
C2	156.11'	100.00	N 00°33'27" E	N 45°11'45" W	140.73'

CURVE #	LENGTH	RADIUS	DELTA	CHORD DIRECTION	CHORD LENGTH
C1	3.56'	25.00	N 81°50'57" E	S 44°05'34" W	3.55'
C2	17.47'	25.00	N 49°57'40" E	S 19°59'52" W	17.12'

LINE #	LENGTH	DIRECTION
L1	25.00'	N 89°31'31" E
L2	31.48'	S 00°28'29" E

LINE #	LENGTH	DIRECTION
L1	35.49'	S 45°14'53" E
L2	35.22'	N 44°45'7" E
L3	35.36"	S 45°01'18" E

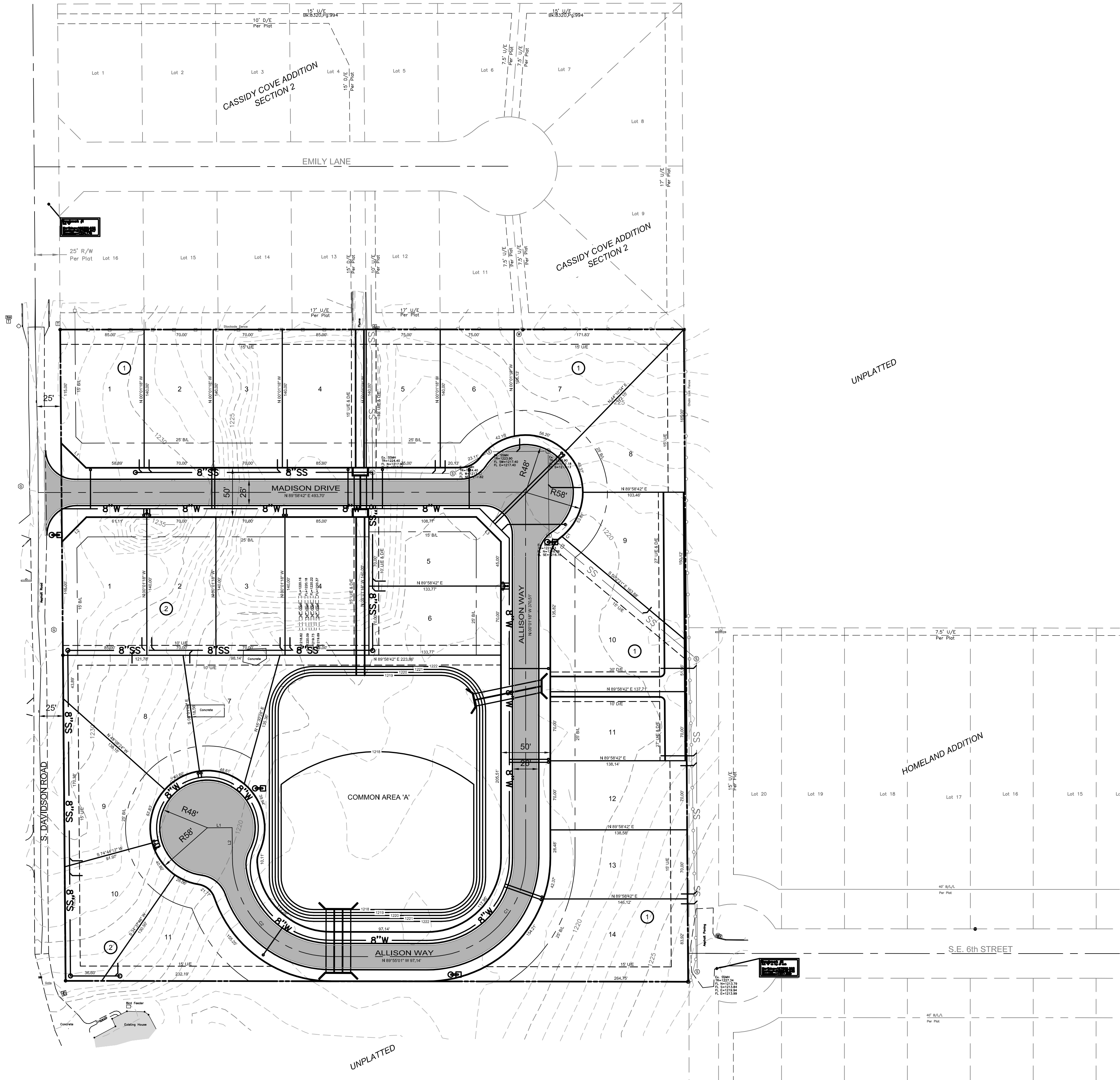

DRAINAGE AREA = 86.4 ACRES
 INFLOW Q = 383.6 CFS

DRAINAGE AREA = 58.3 ACRES
 INFLOW Q = 259.1 CFS

DRAINAGE PLAN

LOCATION MAP:

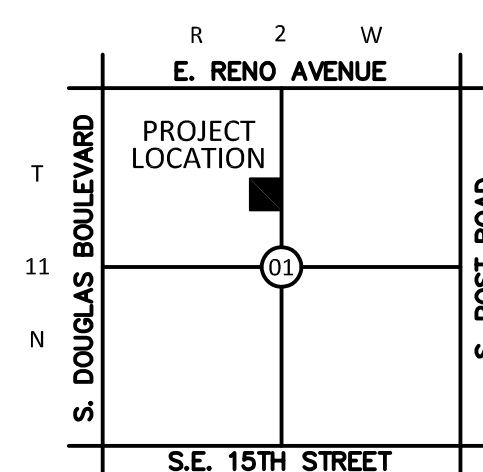

NOT TO SCALE

PROJECT:

CASSIDY COVE

MIDWEST CITY, OKLAHOMA

PROJECT NUMBER: 19013
 DRAWING DATE: 02.25.19
 ISSUE DATE: 02.25.19

SEAL:

SUBMITTAL:

**PRELIMINARY PLAT
 SUBMITTAL**

REVISIONS:

MARK	DATE	DESCRIPTION

THESE PLANS AND DRAWINGS ARE NOT TO BE REPRODUCED, CHANGED OR COPIED IN ANY FORM OR MANNER WHATSOEVER WITHOUT FIRST OBTAINING THE WRITTEN PERMISSION AND CONSENT OF CEDAR CREEK CONSULTING INC. THIS SHEET IS NOT TO BE USED FOR CONSTRUCTION UNLESS THE ISSUE DATE IN THE TITLE BLOCK COINCIDES WITH OR POST DATES THE DRAWING DATE. ANY CHANGES MADE FROM THESE PLANS WITHOUT CONSENT OF CEDAR CREEK CONSULTING INC. ARE UNAUTHORIZED, AND SHALL RELIEVE CEDAR CREEK CONSULTING OF RESPONSIBILITY FOR ALL CONSEQUENCES ARISING OUT OF SUCH CHANGES.

DRAWING TITLE:

**DRAINAGE
 MAP**

SHEET:

C2.00

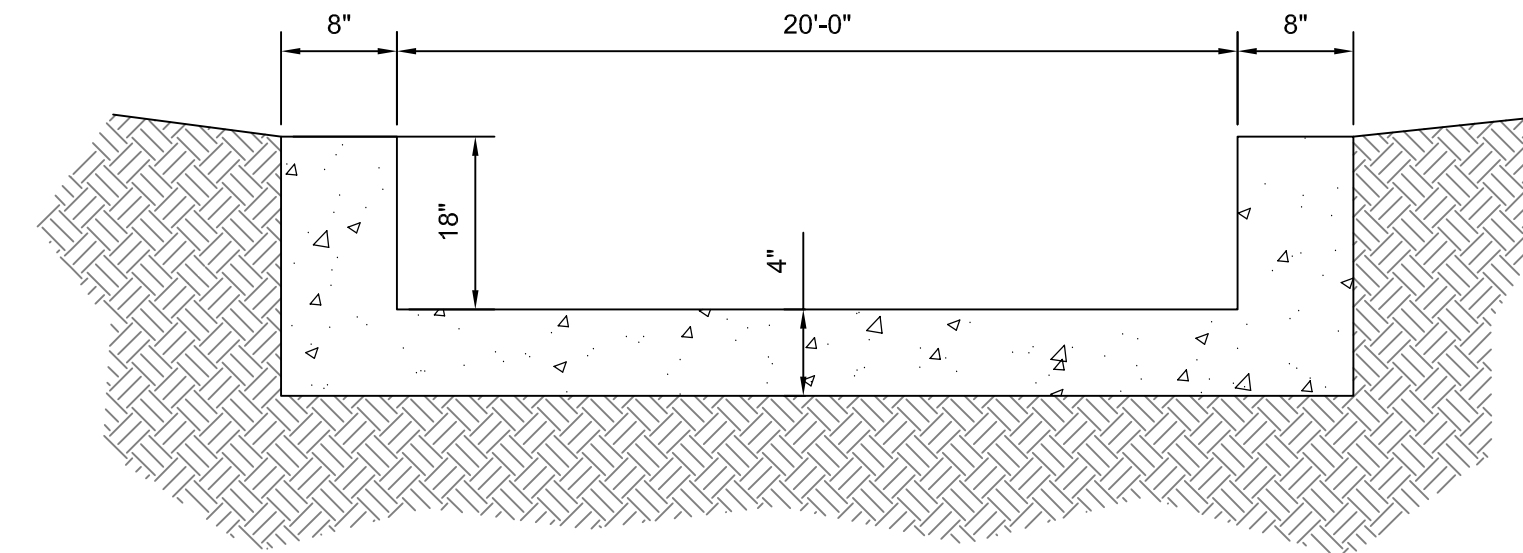
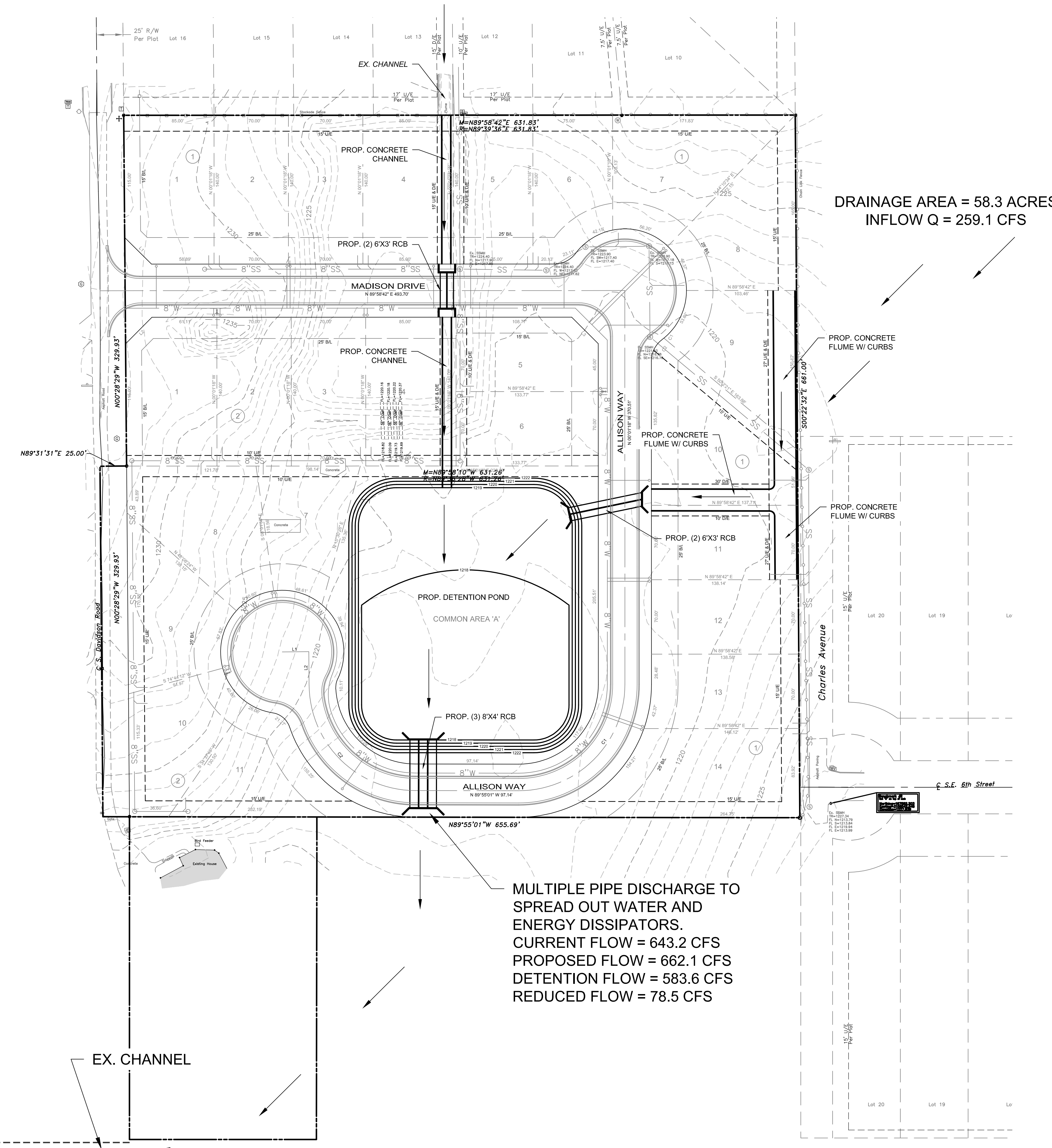

CONCRETE FLUME W/ CURB DETAIL
 NOT TO SCALE

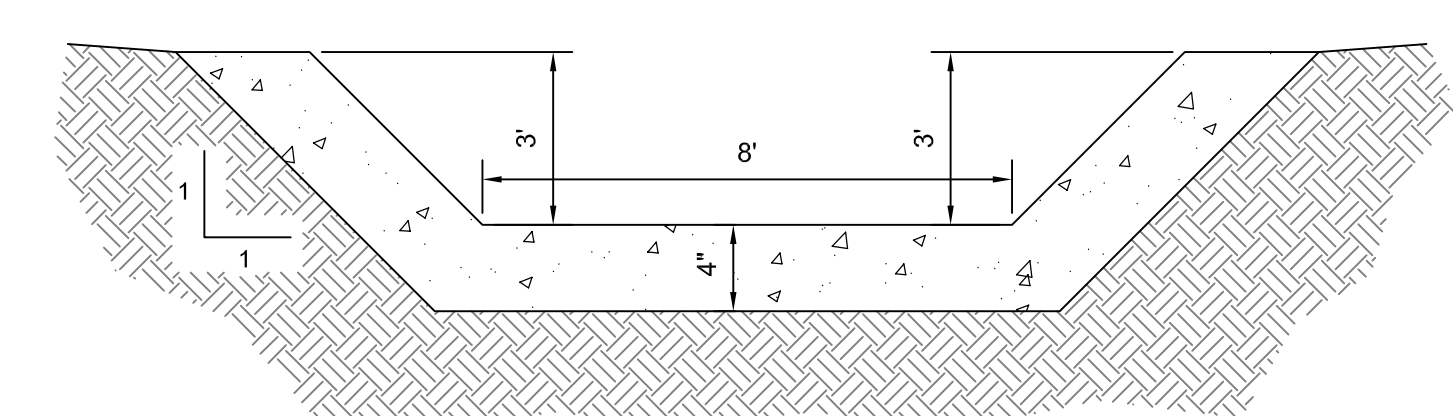

CONCRETE CHANNEL DETAIL
 NOT TO SCALE

MULTIPLE PIPE DISCHARGE TO SPREAD OUT WATER AND ENERGY DISSIPATORS.
 CURRENT FLOW = 643.2 CFS
 PROPOSED FLOW = 662.1 CFS
 DETENTION FLOW = 583.6 CFS
 REDUCED FLOW = 78.5 CFS

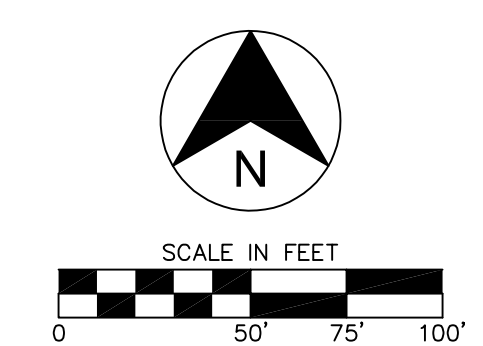

Drainage Calculations

FOR

**Cassidy Cove, Section 3
Midwest City, Oklahoma**

Prepared by:

Cedar Creek Consulting, Inc

PO Box 14534
Oklahoma City, OK 73113
Phone: 405-778-3385

CCC Job #19013

February 26, 2019



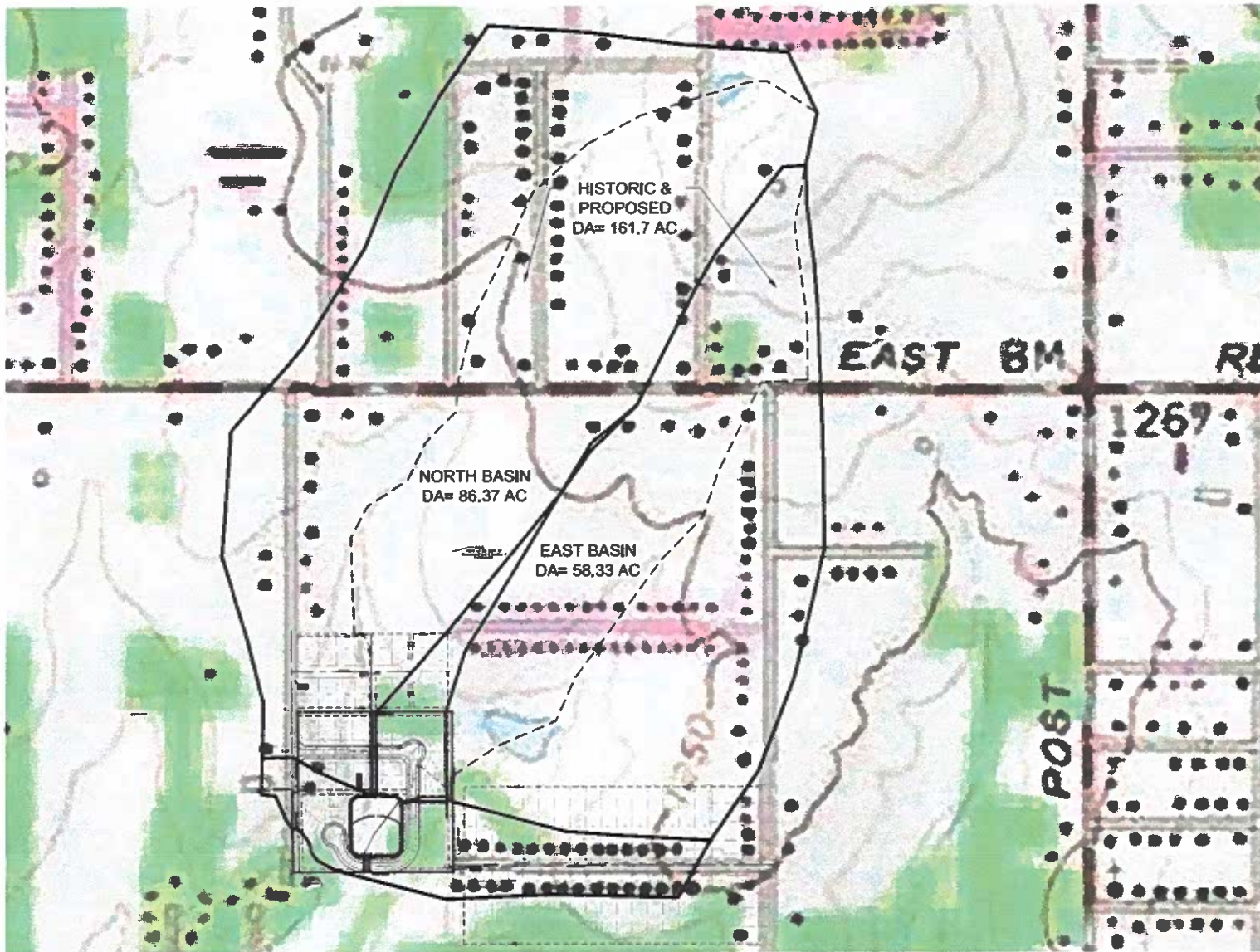

LOCATION MAP



NOT TO SCALE

PROJECT

CASSIDY COVE

MIDWEST CITY, OKLAHOMA

PROJECT NUMBER: 18013
 DRAWING DATE: 02.25.19
 ISSUE DATE: 02.25.19

SCALE

REVISIONS
 SUBMITTAL
 PRELIMINARY PLAT
 SUBMITTAL

NO.	DATE	DESCRIPTION

THESE PLANS AND SPECIFICATIONS ARE PRELIMINARY AND NOT TO BE USED FOR CONSTRUCTION OR FOR ANY OTHER PURPOSE WITHOUT THE WRITTEN CONSENT OF CEDAR CREEK ENGINEERING, ARCHITECTURE & LANDSCAPE ARCHITECTURE. ANY CHANGES TO THESE PLANS AND SPECIFICATIONS SHALL BE MADE BY A SUPPLEMENTAL SHEET. THE USER OF THESE PLANS AND SPECIFICATIONS SHALL BE RESPONSIBLE FOR OBTAINING ALL NECESSARY PERMITS AND APPROVALS FROM THE APPROPRIATE AGENCIES. CEDAR CREEK ENGINEERING, ARCHITECTURE & LANDSCAPE ARCHITECTURE SHALL NOT BE RESPONSIBLE FOR ANY SUCH PERMITS AND APPROVALS.

DRAWING TITLE

OVERALL
 DRAINAGE
 MAP

SHEET

DA1



DRAINAGE BASIN PEAK RUNOFF CALCULATION SPREADSHEET

PROJECT NAME: Cassidy Cove Section 3
 DESCRIPTION: Historic
 OFFICE PROJECT NUMBER: 19013.0
 STATE PROJECT NUMBER:
 OKLAHOMA CLIMATE ZONE: 2
 DRAINAGE BASIN, in acres: 161.7000
 AVERAGE SLOPE OF THE DRAINAGE BASIN, in foot/foot: 0.0100

DATE: 2/26/2019
 DESIGNER: jd
 SPREADSHEET FILE NAME: drainage calc

In order to determine an accurate runoff coefficient, a weighted average of the drainage basin will be made.

Future Anticipated Land use:	Percent of Total Area (%)	*Runoff Coefficient	Partial Area & Coefficient Product
Natural Grass:	9	0.5	7.2765
Pasture:	0	0.45	0
Cultivated:	0	0	0
Commercial:	0	0.9	0
Residential:	91	0.7	103.0029
Paved:	0	0.95	0
**Percentage of Total Area:	100	Sum of Coefficient Products:	110.2794

To calculate the Weighted "C" Coefficient, divide the Sum of Coefficient Products by the total Drainage Basin.

WEIGHTED "C" COEFFICIENT TO BE USED: 0.68

Land Use	Coefficient	Land Use	Coefficient
Downtown Business Areas	0.85 - 0.95	Streets, Drives and Walks	0.90 - 0.95
Neighborhood Business Areas	0.60 - 0.75	Lawns, Parks and Cemeteries	0.30 - 0.50
Residential Areas	0.55 - 0.70	Agricultural and Pasture Land	0.50 - 0.70
Industrial Areas	0.70 - 0.80	Woodlands and Timber	0.05 - 0.25

A. Overland Flow:

Length of overland flow, L_o, in feet: 1025 (As determined by survey, USGS mapping, aerial survey, ect.)
 Overland average slope, S_o, in feet: 0.034 (As determined by survey, USGS mapping, aerial survey, ect.)

If the overland flow path crosses different types of ground cover a weighted "K" factor must be calculated.

Ground Cover	Percent of Total Length (%)	K Factor	Partial Length & K Factor Product
Pavement:	0	0.372	0
Commercial:	0	0.445	0
Residential:	100	0.511	523.775
Rocky, Bare Soil:	0	0.604	0
Cultivated:	0	0.775	0
Timber, Thin Grass:	0	0.942	0
Average Pasture:	0	1.04	0
Tall Grass:	0	1.113	0
**Percentage of Total Length:	100	Sum of "K" Factor Products:	523.775

WEIGHTED OVERLAND "K" FACTOR TO BE USED: 0.5110

Therefore the time of concentration for the overland flow can be calculated from the equation:

$$T_o = K(L_o)^{0.37} / S_o^{0.2} \quad T_o = 13.06 \text{ minutes}$$

B. Channel Flow:

Length of channel flow, L_c, in feet: 3080.00 (As determined by survey, USGS mapping, aerial survey, etc.)
 Channel average slope, S_c, in feet: 0.0130 (As determined by survey, USGS mapping, aerial survey, etc.)
 Channel condition "K" Factor: 0.0059

Channel Condition	"K" Factor	Channel Condition	"K" Factor
Straight, clean stream	0.00592	Meandering stream with pools	0.0102
Average stream, few obstructions	0.00835	V-Ditch	0.01252

The time of concentration for the Channel flow can be calculated from the equation:

$$T_c = K(L_c)^{0.77} / S_c^{0.385} \quad T_c = 15.30 \text{ minutes}$$

TIME OF CONCENTRATION TO BE USED, TC = 28.36 minutes

$$I = a / (TC + b)$$

	2 year	5 year	10 year	25 year	50 year	100 year
a =	104.333	79.655	87.535	101.482	98.925	102.769
b =	17.298	14.826	15.882	16.774	15.865	15.860
c =	0.935	0.825	0.811	0.806	0.775	0.760

Rainfall Intensity for the listed Event:	1 2 =	1 5 =	1 10 =	1 25 =	1 50 =	1 100 =
	2.93	3.56	4.04	4.71	5.24	5.76 in/hour

A - Area in units of acres
 C - Runoff coefficient of the drainage basin
 I - Average historical rainfall intensity in units of inches/hour

$$Q = A \times C \times I$$

DRAINAGE BASIN RUNOFF FOR THE 100 YEAR RAINFALL EVENT:	635.41 cfs
DRAINAGE BASIN RUNOFF FOR THE 50 YEAR RAINFALL EVENT:	577.84 cfs
DRAINAGE BASIN RUNOFF FOR THE 25 YEAR RAINFALL EVENT:	519.44 cfs
DRAINAGE BASIN RUNOFF FOR THE 10 YEAR RAINFALL EVENT:	445.99 cfs
DRAINAGE BASIN RUNOFF FOR THE 5 YEAR RAINFALL EVENT:	392.93 cfs
DRAINAGE BASIN RUNOFF FOR THE 2 YEAR RAINFALL EVENT:	323.21 cfs

DRAINAGE BASIN PEAK RUNOFF CALCULATION SPREADSHEET

PROJECT NAME: Cassidy Cove Section 3
 DESCRIPTION: Developed DATE: 2/28/2019
 OFFICE PROJECT NUMBER: 19010.0 DESIGNER: Jd
 STATE PROJECT NUMBER: SPREADSHEET FILE NAME: drainage calc
 OKLAHOMA CLIMATE ZONE: 2
DRAINAGE BASIN, in acres: 161.7000
 AVERAGE SLOPE OF THE DRAINAGE BASIN, in foot/foot: 0.0100

In order to determine an accurate runoff coefficient, a weighted average of the drainage basin will be made.

Future Anticipated Land use:	Percent of Total Area (%)	*Runoff Coefficient	Partial Area & Coefficient Product
Natural Grass:	0	0.5	0
Pasture:	0	0.45	0
Cultivated:	0	0	0
Commercial:	0	0.9	0
Residential:	100	0.7	113.19
Paved:	0	0.95	0
**Percentage of Total Area: 100			Sum of Coefficient Products: 113.19

To calculate the Weighted "C" Coefficient, divide the Sum of Coefficient Products by the total Drainage Basin.

WEIGHTED "C" COEFFICIENT TO BE USED: 0.70

Land Use	Coefficient	Land Use	Coefficient
Downtown Business Areas	0.85 - 0.95	Streets, Drives and Walks	0.90 - 0.95
Neighborhood Business Areas	0.80 - 0.75	Lawns, Parks and Cemeteries	0.30 - 0.50
Residential Areas	0.55 - 0.70	Agricultural and Pasture Land	0.50 - 0.70
Industrial Areas	0.70 - 0.80	Woodlands and Timber	0.05 - 0.25

A. Overland Flow:

Length of overland flow, L_o, in feet: 1025 (As determined by survey, USGS mapping, aerial survey, ect.)
 Overland average slope, S_o, in feet: 0.034 (As determined by survey, USGS mapping, aerial survey, ect.)

If the overland flow path crosses different types of ground cover a weighted "K" factor must be calculated.

Ground Cover	Percent of Total Length (%)	K Factor	Partial Length & K Factor Product
Pavement:	0	0.372	0
Commercial:	0	0.445	0
Residential:	100	0.511	523.775
Rocky, Bare Soil:	0	0.604	0
Cultivated:	0	0.775	0
Timber, Thin Grass:	0	0.942	0
Average Pasture:	0	1.04	0
Tall Grass:	0	1.113	0
**Percentage of Total Length: 100			Sum of "K" Factor Products: 523.775

WEIGHTED OVERLAND "K" FACTOR TO BE USED: 0.5116

Therefore the time of concentration for the overland flow can be calculated from the equation:

$$T_o = K(L_o)^{0.37} / S_o^{0.2} \quad T_o = 13.06 \text{ minutes}$$

B. Channel Flow:

Length of channel flow, L_c, in feet: 3080.00 (As determined by survey, USGS mapping, aerial survey, etc.)
 Channel average slope, S_c, in feet: 0.0130 (As determined by survey, USGS mapping, aerial survey, etc.)
 Channel condition "K" Factor: 0.0058

Channel Condition	*K* Factor	Channel Condition	*K* Factor
Straight, clean stream	0.00592	Meandering stream with pools	0.0102
Average stream, few obstructions	0.00835	V-Ditch	0.01252

The time of concentration for the Channel flow can be calculated from the equation:

$$T_c = K'(L_c)^{0.77} / S_c^{0.385} \quad T_c = 15.30 \text{ minutes}$$

TIME OF CONCENTRATION TO BE USED, TC = 28.36 minutes

$$I = a / (TC + b)$$

	2 year	5 year	10 year	25 year	50 year	100 year
a =	104.333	79.655	67.535	101.482	98.925	102.769
b =	17.298	14.828	15.892	16.774	15.865	15.860
c =	0.935	0.825	0.811	0.806	0.775	0.760

Rainfall Intensity for the listed Event:	12 =	15 =	110 =	125 =	150 =	1100 =
	2.93	3.56	4.04	4.71	5.24	5.76 in/hour

A - Area in units of acres

Q = A x C x I

C - Runoff coefficient of the drainage basin
 I - Average historical rainfall intensity in units of inches/hour

DRAINAGE BASIN RUNOFF FOR THE 100 YEAR RAINFALL EVENT:	652.18 cfs
DRAINAGE BASIN RUNOFF FOR THE 50 YEAR RAINFALL EVENT:	593.09 cfs
DRAINAGE BASIN RUNOFF FOR THE 25 YEAR RAINFALL EVENT:	533.15 cfs
DRAINAGE BASIN RUNOFF FOR THE 10 YEAR RAINFALL EVENT:	457.76 cfs
DRAINAGE BASIN RUNOFF FOR THE 5 YEAR RAINFALL EVENT:	403.30 cfs
DRAINAGE BASIN RUNOFF FOR THE 2 YEAR RAINFALL EVENT:	331.74 cfs

DRAINAGE BASIN PEAK RUNOFF CALCULATION SPREADSHEET

PROJECT NAME: **Casldy Cove Section 3**
 DESCRIPTION: **East Basin** DATE: **2/26/2019**
 OFFICE PROJECT NUMBER: **19010.0** DESIGNER: **jd**
 STATE PROJECT NUMBER: _____ SPREADSHEET FILE NAME: **drainage calc**
 OKLAHOMA CLIMATE ZONE: **2**
DRAINAGE BASIN, in acres : **58.3300**
AVERAGE SLOPE OF THE DRAINAGE BASIN, in foot/foot: **0.0100**

In order to determine an accurate runoff coefficient, a weighted average of the drainage basin will be made.

Future Anticipated Land use:	Percent of Total Area (%)	*Runoff Coefficient	Partial Area & Coefficient Product
Natural Grass:	0	0.5	0
Pasture:	0	0.45	0
Cultivated:	0	0	0
Commercial:	0	0.9	0
Residential:	100	0.7	40.831
Paved:	0	0.95	0
**Percentage of Total Area:	100	Sum of Coefficient Products:	40.831

To calculate the Weighted "C" Coefficient, divide the Sum of Coefficient Products by the total Drainage Basin.

WEIGHTED "C" COEFFICIENT TO BE USED: 0.70

Land Use	Coefficient	Land Use	Coefficient
Downtown Business Areas	0.85 - 0.95	Streets, Drives and Walks	0.90 - 0.95
Neighborhood Business Areas	0.60 - 0.75	Lawns, Parks and Cemeteries	0.30 - 0.50
Residential Areas	0.55 - 0.70	Agricultural and Pasture Land	0.50 - 0.70
Industrial Areas	0.70 - 0.80	Woodlands and Timber	0.05 - 0.25

A. Overland Flow:

Length of overland flow, L_s, in feet: **887** (As determined by survey, USGS mapping, aerial survey, etc.)
 Overland average slope, S_s, in feet: **0.028** (As determined by survey, USGS mapping, aerial survey, etc.)

If the overland flow path crosses different types of ground cover a weighted "K" factor must be calculated.

Ground Cover	Percent of Total Length (%)	K Factor	Partial Length & K Factor Product
Pavement:	0	0.372	0
Commercial:	0	0.445	0
Residential:	100	0.511	453.257
Rocky, Bare Soil:	0	0.604	0
Cultivated:	0	0.775	0
Timber, Thin Grass:	0	0.942	0
Average Pasture:	0	1.04	0
Tall Grass:	0	1.113	0
**Percentage of Total Length:	100	Sum of "K" Factor Products:	453.257

WEIGHTED OVERLAND "K" FACTOR TO BE USED: 0.5110

Therefore the time of concentration for the overland flow can be calculated from the equation:

$$T_o = K (L_s)^{0.37} / S_s^{0.2} \quad T_o = 12.87 \text{ minutes}$$

B. Channel Flow:

Length of channel flow, L_c, in feet: **2320.00** (As determined by survey, USGS mapping, aerial survey, etc.)
 Channel average slope, S_c, in feet: **0.0210** (As determined by survey, USGS mapping, aerial survey, etc.)
 Channel condition "K" Factor: **0.0050**

Channel Condition	"K" Factor	Channel Condition	"K" Factor
Straight, clean stream	0.00592	Meandering stream with pools	0.0102
Average stream, few obstructions	0.00835	V-Ditch	0.01252

The time of concentration for the Channel flow can be calculated from the equation:

$$T_c = K' (L_c)^{0.77} / S_c^{0.385} \quad T_c = 10.23 \text{ minutes}$$

TIME OF CONCENTRATION TO BE USED, TC = 23.10 minutes

$$I = a / (TC + b)$$

	2 year	5 year	10 year	25 year	50 year	100 year
a =	104.333	79.655	67.535	101.482	98.925	102.769
b =	17.298	14.828	15.892	16.774	15.865	15.860
c =	0.935	0.825	0.811	0.806	0.775	0.760

Rainfall Intensity for the listed Event:	12 =	15 =	10 =	125 =	150 =	1100 =
	3.29	3.97	4.48	5.21	5.78	6.34 in/hour

Q = A x C x I
 A - Area in units of acres
 C - Runoff coefficient of the drainage basin
 I - Average historical rainfall intensity in units of inches/hour

DRAINAGE BASIN RUNOFF FOR THE 100 YEAR RAINFALL EVENT:	259.05 cfs
DRAINAGE BASIN RUNOFF FOR THE 50 YEAR RAINFALL EVENT:	236.03 cfs
DRAINAGE BASIN RUNOFF FOR THE 25 YEAR RAINFALL EVENT:	212.53 cfs
DRAINAGE BASIN RUNOFF FOR THE 10 YEAR RAINFALL EVENT:	182.99 cfs
DRAINAGE BASIN RUNOFF FOR THE 5 YEAR RAINFALL EVENT:	161.95 cfs
DRAINAGE BASIN RUNOFF FOR THE 2 YEAR RAINFALL EVENT:	134.18 cfs

DRAINAGE BASIN PEAK RUNOFF CALCULATION SPREADSHEET

PROJECT NAME: Cassidy Cove Section 3
DESCRIPTION: Main Channel **DATE:** 2/26/2019
OFFICE PROJECT NUMBER: 19013.0 **DESIGNER:** jd
STATE PROJECT NUMBER: **SPREADSHEET FILE NAME:** drainage calc
OKLAHOMA CLIMATE ZONE: 2
DRAINAGE BASIN, in acres: 86.3700
AVERAGE SLOPE OF THE DRAINAGE BASIN, in foot/foot: 0.0100

In order to determine an accurate runoff coefficient, a weighted average of the drainage basin will be made.

Future Anticipated Land use:	Percent of Total Area (%)	*Runoff Coefficient	Partial Area & Coefficient Product
Natural Grass:	0	0.5	0
Pasture:	0	0.45	0
Cultivated:	0	0	0
Commercial:	0	0.9	0
Residential:	100	0.7	80.459
Paved:	0	0.95	0
**Percentage of Total Area:	100	Sum of Coefficient Products:	80.459

To calculate the Weighted "C" Coefficient, divide the Sum of Coefficient Products by the total Drainage Basin.

WEIGHTED "C" COEFFICIENT TO BE USED: 0.70

Land Use	Coefficient	Land Use	Coefficient
Downtown Business Areas	0.85 - 0.95	Streets, Drives and Walks	0.90 - 0.95
Neighborhood Business Areas	0.60 - 0.75	Lawns, Parks and Cemeteries	0.30 - 0.50
Residential Areas	0.55 - 0.70	Agricultural and Pasture Land	0.50 - 0.70
Industrial Areas	0.70 - 0.80	Woodlands and Timber	0.05 - 0.25

A. Overland Flow:

Length of overland flow, L, in feet: **887** (As determined by survey, USGS mapping, aerial survey, ect.)
 Overland average slope, S, in feet: **0.028** (As determined by survey, USGS mapping, aerial survey, ect.)

If the overland flow path crosses different types of ground cover a weighted "K" factor must be calculated.

Ground Cover	Percent of Total Length (%)	K Factor	Partial Length & K Factor Product
Pavement:	0	0.372	0
Commercial:	0	0.445	0
Residential:	100	0.511	453.257
Rocky, Bare Soil:	0	0.604	0
Cultivated:	0	0.775	0
Timber, Thin Grass:	0	0.942	0
Average Pasture:	0	1.04	0
Tall Grass:	0	1.113	0
**Percentage of Total Length:	100	Sum of "K" Factor Products:	453.257

WEIGHTED OVERLAND "K" FACTOR TO BE USED: 0.5110

Therefore the time of concentration for the overland flow can be calculated from the equation:

$$T_o = K(L)^{0.37} / S^{0.2} \quad T_o = 12.87 \text{ minutes}$$

B. Channel Flow:

Length of channel flow, L, in feet: **2320.00** (As determined by survey, USGS mapping, aerial survey, etc.)
 Channel average slope, S, in feet: **0.0210** (As determined by survey, USGS mapping, aerial survey, etc.)
 Channel condition "K" Factor: **0.0059**

Channel Condition	"K" Factor	Channel Condition	"K" Factor
Straight, clean stream	0.00592	Meandering stream with pools	0.0102
Average stream, few obstructions	0.00835	V-Ditch	0.01252

The time of concentration for the Channel flow can be calculated from the equation:

$$T_c = K(L)^{0.77} / S^{0.385} \quad T_c = 10.23 \text{ minutes}$$

TIME OF CONCENTRATION TO BE USED, TC = 23.10 minutes

$$I = a / (TC + b)$$

	2 year	5 year	10 year	25 year	50 year	100 year
a =	104.333	79.655	87.535	101.482	98.925	102.769
b =	17.298	14.828	15.882	16.774	15.885	15.880
c =	0.935	0.825	0.811	0.806	0.775	0.760
Rainfall Intensity for the listed Event:	I 2 = 3.29	I 5 = 3.97	I 10 = 4.48	I 25 = 5.21	I 50 = 5.78	I 100 = 6.34 in/hour

Q = A x C x I
 A - Area in units of acres
 C - Runoff coefficient of the drainage basin
 I - Average historical rainfall intensity in units of inches/hour

DRAINAGE BASIN RUNOFF FOR THE 100 YEAR RAINFALL EVENT:	383.58 cfs
DRAINAGE BASIN RUNOFF FOR THE 50 YEAR RAINFALL EVENT:	349.49 cfs
DRAINAGE BASIN RUNOFF FOR THE 25 YEAR RAINFALL EVENT:	314.69 cfs
DRAINAGE BASIN RUNOFF FOR THE 10 YEAR RAINFALL EVENT:	270.96 cfs
DRAINAGE BASIN RUNOFF FOR THE 5 YEAR RAINFALL EVENT:	239.80 cfs
DRAINAGE BASIN RUNOFF FOR THE 2 YEAR RAINFALL EVENT:	198.69 cfs



Historic



Developed



Detention Pond



19013 Pond

Prepared by Windows User

HydroCAD® 10.00-15 s/n 07286 © 2015 HydroCAD Software Solutions LLC

Printed 2/26/2019

Page 2

Area Listing (all nodes)

Area (acres)	C	Description (subcatchment-numbers)
161.700	0.70	Fully Developed (3S)
161.700	0.68	Historic (1S)
323.400	0.69	TOTAL AREA

19013 Pond

Oklahoma Zone II 100-Year Duration=28 min, Inten=5.92 in/hr

Prepared by Windows User

Printed 2/26/2019

HydroCAD® 10.00-15 s/n 07286 © 2015 HydroCAD Software Solutions LLC

Page 3

Time span=0.00-3.00 hrs, dt=0.01 hrs, 301 points

Runoff by Rational method, Rise/Fall=1.0/1.0 xTc

Reach routing by Stor-Ind+Trans method - Pond routing by Stor-Ind method

Subcatchment1S: Historic

Runoff Area=161.700 ac 0.00% Impervious Runoff Depth=1.85"
Tc=28.4 min C=0.68 Runoff=643.20 cfs 24.961 af

Subcatchment3S: Developed

Runoff Area=161.700 ac 0.00% Impervious Runoff Depth=1.91"
Tc=28.4 min C=0.70 Runoff=662.12 cfs 25.696 af

Pond 4P: Detention Pond

Peak Elev=1,221.79' Storage=188,742 cf Inflow=662.12 cfs 25.696 af
96.0" x 48.0" Box Culvert x 3.00 n=0.013 L=65.0' S=0.0040 '/' Outflow=583.63 cfs 25.696 af

Total Runoff Area = 323.400 ac Runoff Volume = 50.657 af Average Runoff Depth = 1.88"
100.00% Pervious = 323.400 ac 0.00% Impervious = 0.000 ac

19013 Pond

Oklahoma Zone II 100-Year Duration=28 min, Inten=5.92 in/hr

Prepared by Windows User

Printed 2/26/2019

HydroCAD® 10.00-15 s/n 07286 © 2015 HydroCAD Software Solutions LLC

Page 4

Summary for Subcatchment 1S: Historic

Runoff = 643.20 cfs @ 0.47 hrs, Volume= 24.961 af, Depth= 1.85"

Runoff by Rational method, Rise/Fall=1.0/1.0 xTc, Time Span= 0.00-3.00 hrs, dt= 0.01 hrs
Oklahoma Zone II 100-Year Duration=28 min, Inten=5.92 in/hr

Area (ac)	C	Description
161.700	0.68	Historic
161.700		100.00% Pervious Area

Tc (min)	Length (feet)	Slope (ft/ft)	Velocity (ft/sec)	Capacity (cfs)	Description
28.4					Direct Entry, Tc

Subcatchment 1S: Historic

Hydrograph

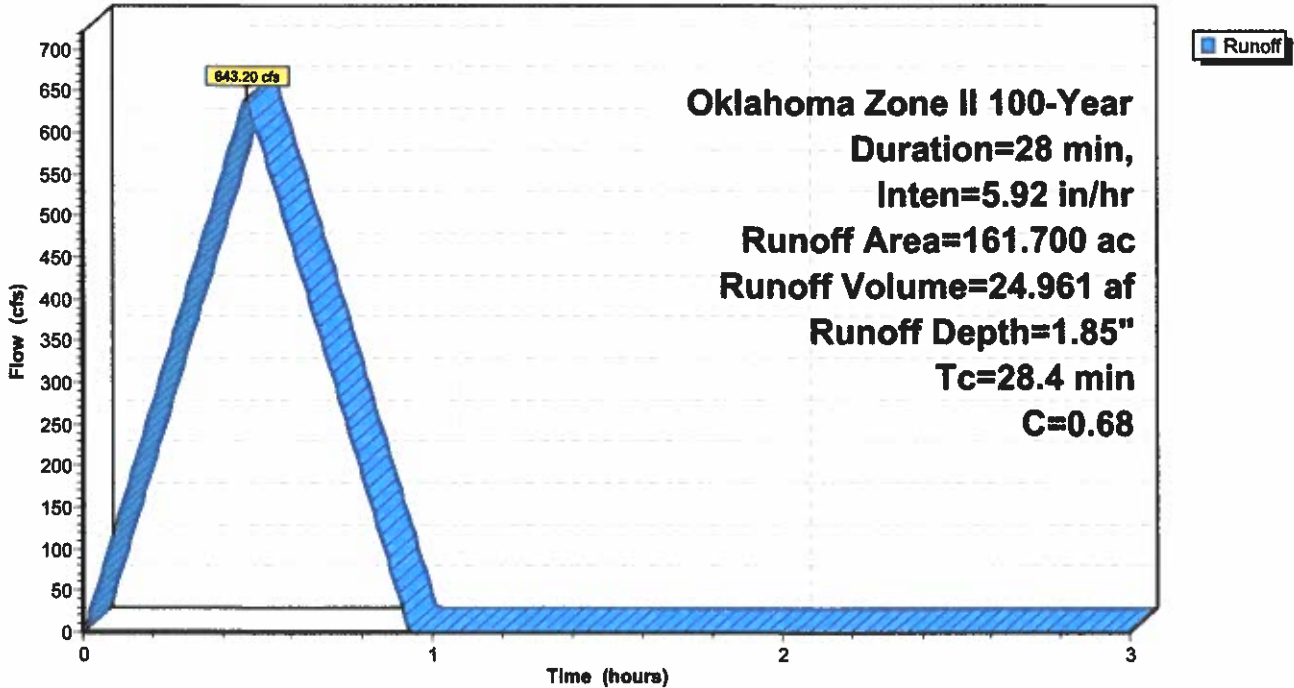

19013 Pond*Oklahoma Zone II 100-Year Duration=28 min, Inten=5.92 in/hr*

Prepared by Windows User

Printed 2/26/2019

HydroCAD® 10.00-15 s/n 07286 © 2015 HydroCAD Software Solutions LLC

Page 5

Hydrograph for Subcatchment 1S: Historic

Time (hours)	Runoff (cfs)	Time (hours)	Runoff (cfs)	Time (hours)	Runoff (cfs)
0.00	0.00	1.04	0.00	2.08	0.00
0.02	27.74	1.06	0.00	2.10	0.00
0.04	55.48	1.08	0.00	2.12	0.00
0.06	83.22	1.10	0.00	2.14	0.00
0.08	110.96	1.12	0.00	2.16	0.00
0.10	138.70	1.14	0.00	2.18	0.00
0.12	166.43	1.16	0.00	2.20	0.00
0.14	194.17	1.18	0.00	2.22	0.00
0.16	221.91	1.20	0.00	2.24	0.00
0.18	249.65	1.22	0.00	2.26	0.00
0.20	277.39	1.24	0.00	2.28	0.00
0.22	305.13	1.26	0.00	2.30	0.00
0.24	332.87	1.28	0.00	2.32	0.00
0.26	360.61	1.30	0.00	2.34	0.00
0.28	388.35	1.32	0.00	2.36	0.00
0.30	416.09	1.34	0.00	2.38	0.00
0.32	443.83	1.36	0.00	2.40	0.00
0.34	471.56	1.38	0.00	2.42	0.00
0.36	499.30	1.40	0.00	2.44	0.00
0.38	527.04	1.42	0.00	2.46	0.00
0.40	554.78	1.44	0.00	2.48	0.00
0.42	582.52	1.46	0.00	2.50	0.00
0.44	610.26	1.48	0.00	2.52	0.00
0.46	638.00	1.50	0.00	2.54	0.00
0.48	628.75	1.52	0.00	2.56	0.00
0.50	601.01	1.54	0.00	2.58	0.00
0.52	573.27	1.56	0.00	2.60	0.00
0.54	545.54	1.58	0.00	2.62	0.00
0.56	517.80	1.60	0.00	2.64	0.00
0.58	490.06	1.62	0.00	2.66	0.00
0.60	462.32	1.64	0.00	2.68	0.00
0.62	434.58	1.66	0.00	2.70	0.00
0.64	406.84	1.68	0.00	2.72	0.00
0.66	379.10	1.70	0.00	2.74	0.00
0.68	351.36	1.72	0.00	2.76	0.00
0.70	323.62	1.74	0.00	2.78	0.00
0.72	295.88	1.76	0.00	2.80	0.00
0.74	268.14	1.78	0.00	2.82	0.00
0.76	240.41	1.80	0.00	2.84	0.00
0.78	212.67	1.82	0.00	2.86	0.00
0.80	184.93	1.84	0.00	2.88	0.00
0.82	157.19	1.86	0.00	2.90	0.00
0.84	129.45	1.88	0.00	2.92	0.00
0.86	101.71	1.90	0.00	2.94	0.00
0.88	73.97	1.92	0.00	2.96	0.00
0.90	46.23	1.94	0.00	2.98	0.00
0.92	18.49	1.96	0.00	3.00	0.00
0.94	0.00	1.98	0.00		
0.96	0.00	2.00	0.00		
0.98	0.00	2.02	0.00		
1.00	0.00	2.04	0.00		
1.02	0.00	2.06	0.00		

19013 Pond

Oklahoma Zone II 100-Year Duration=28 min, Inten=5.92 in/hr

Prepared by Windows User

Printed 2/26/2019

HydroCAD® 10.00-15 s/n 07286 © 2015 HydroCAD Software Solutions LLC

Page 6

Summary for Subcatchment 3S: Developed

Runoff = 662.12 cfs @ 0.47 hrs, Volume= 25.696 af, Depth= 1.91"

Runoff by Rational method, Rise/Fall=1.0/1.0 xTc, Time Span= 0.00-3.00 hrs, dt= 0.01 hrs
Oklahoma Zone II 100-Year Duration=28 min, Inten=5.92 in/hr

Area (ac)	C	Description
161.700	0.70	Fully Developed
161.700		100.00% Pervious Area

Tc (min)	Length (feet)	Slope (ft/ft)	Velocity (ft/sec)	Capacity (cfs)	Description
28.4					Direct Entry, Tc

Subcatchment 3S: Developed

Hydrograph

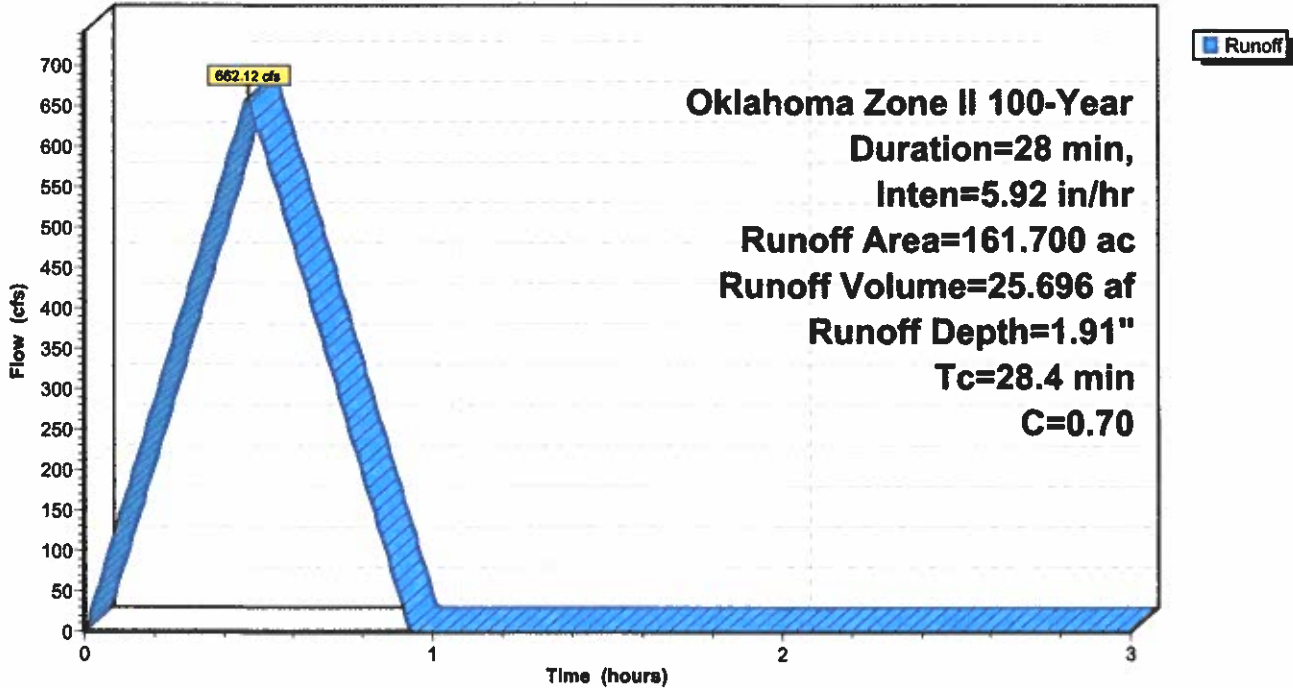

19013 Pond

Oklahoma Zone II 100-Year Duration=28 min, Inten=5.92 in/hr

Prepared by Windows User

Printed 2/26/2019

HydroCAD® 10.00-15 s/n 07286 © 2015 HydroCAD Software Solutions LLC

Page 7

Hydrograph for Subcatchment 3S: Developed

Time (hours)	Runoff (cfs)	Time (hours)	Runoff (cfs)	Time (hours)	Runoff (cfs)
0.00	0.00	1.04	0.00	2.08	0.00
0.02	28.55	1.06	0.00	2.10	0.00
0.04	57.11	1.08	0.00	2.12	0.00
0.06	85.66	1.10	0.00	2.14	0.00
0.08	114.22	1.12	0.00	2.16	0.00
0.10	142.77	1.14	0.00	2.18	0.00
0.12	171.33	1.16	0.00	2.20	0.00
0.14	199.88	1.18	0.00	2.22	0.00
0.16	228.44	1.20	0.00	2.24	0.00
0.18	256.99	1.22	0.00	2.26	0.00
0.20	285.55	1.24	0.00	2.28	0.00
0.22	314.10	1.26	0.00	2.30	0.00
0.24	342.66	1.28	0.00	2.32	0.00
0.26	371.21	1.30	0.00	2.34	0.00
0.28	399.77	1.32	0.00	2.36	0.00
0.30	428.32	1.34	0.00	2.38	0.00
0.32	456.88	1.36	0.00	2.40	0.00
0.34	485.43	1.38	0.00	2.42	0.00
0.36	513.99	1.40	0.00	2.44	0.00
0.38	542.54	1.42	0.00	2.46	0.00
0.40	571.10	1.44	0.00	2.48	0.00
0.42	599.65	1.46	0.00	2.50	0.00
0.44	628.21	1.48	0.00	2.52	0.00
0.46	656.76	1.50	0.00	2.54	0.00
0.48	647.25	1.52	0.00	2.56	0.00
0.50	618.69	1.54	0.00	2.58	0.00
0.52	590.14	1.56	0.00	2.60	0.00
0.54	561.58	1.58	0.00	2.62	0.00
0.56	533.03	1.60	0.00	2.64	0.00
0.58	504.47	1.62	0.00	2.66	0.00
0.60	475.92	1.64	0.00	2.68	0.00
0.62	447.36	1.66	0.00	2.70	0.00
0.64	418.81	1.68	0.00	2.72	0.00
0.66	390.25	1.70	0.00	2.74	0.00
0.68	361.70	1.72	0.00	2.76	0.00
0.70	333.14	1.74	0.00	2.78	0.00
0.72	304.59	1.76	0.00	2.80	0.00
0.74	276.03	1.78	0.00	2.82	0.00
0.76	247.48	1.80	0.00	2.84	0.00
0.78	218.92	1.82	0.00	2.86	0.00
0.80	190.37	1.84	0.00	2.88	0.00
0.82	161.81	1.86	0.00	2.90	0.00
0.84	133.26	1.88	0.00	2.92	0.00
0.86	104.70	1.90	0.00	2.94	0.00
0.88	76.15	1.92	0.00	2.96	0.00
0.90	47.59	1.94	0.00	2.98	0.00
0.92	19.04	1.96	0.00	3.00	0.00
0.94	0.00	1.98	0.00		
0.96	0.00	2.00	0.00		
0.98	0.00	2.02	0.00		
1.00	0.00	2.04	0.00		
1.02	0.00	2.06	0.00		

19013 Pond

Oklahoma Zone II 100-Year Duration=28 min, Inten=5.92 in/hr

Prepared by Windows User

Printed 2/26/2019

HydroCAD® 10.00-15 s/n 07286 © 2015 HydroCAD Software Solutions LLC

Page 8

Summary for Pond 4P: Detention Pond

Inflow Area = 161.700 ac, 0.00% Impervious, Inflow Depth = 1.91" for 100-Year event
 Inflow = 662.12 cfs @ 0.47 hrs, Volume= 25.696 af
 Outflow = 583.63 cfs @ 0.52 hrs, Volume= 25.696 af, Atten= 12%, Lag= 3.4 min
 Primary = 583.63 cfs @ 0.52 hrs, Volume= 25.696 af

Routing by Stor-Ind method, Time Span= 0.00-3.00 hrs, dt= 0.01 hrs
 Peak Elev= 1,221.79' @ 0.52 hrs Surf.Area= 54,317 sf Storage= 188,742 cf

Plug-Flow detention time= 5.5 min calculated for 25.696 af (100% of inflow)
 Center-of-Mass det. time= 5.5 min (33.5 - 28.0)

Volume	Invert	Avail.Storage	Storage Description
#1	1,217.36'	200,139 cf	Custom Stage Data (Prismatic) Listed below (Recalc)

Elevation (feet)	Surf.Area (sq-ft)	Inc.Store (cubic-feet)	Cum.Store (cubic-feet)
1,217.36	0	0	0
1,218.00	28,692	9,181	9,181
1,219.00	47,217	37,955	47,136
1,220.00	49,708	48,463	95,598
1,221.00	52,256	50,982	146,580
1,222.00	54,861	53,559	200,139

Device	Routing	Invert	Outlet Devices
#1	Primary	1,217.36'	96.0" W x 48.0" H Box Culvert X 3.00 L= 65.0' Box, headwall w/3 square edges, Ke= 0.500 Inlet / Outlet Invert= 1,217.36' / 1,217.10' S= 0.0040 ' S= 0.0040 ' Cc= 0.900 n= 0.013, Flow Area= 32.00 sf

Primary OutFlow Max=583.39 cfs @ 0.52 hrs HW=1,221.79' (Free Discharge)
 1=Culvert (Barrel Controls 583.39 cfs @ 7.32 fps)

19013 Pond

Oklahoma Zone II 100-Year Duration=28 min, Inten=5.92 in/hr

Prepared by Windows User

Printed 2/26/2019

HydroCAD® 10.00-15 s/n 07286 © 2015 HydroCAD Software Solutions LLC

Page 9

Pond 4P: Detention Pond

Hydrograph

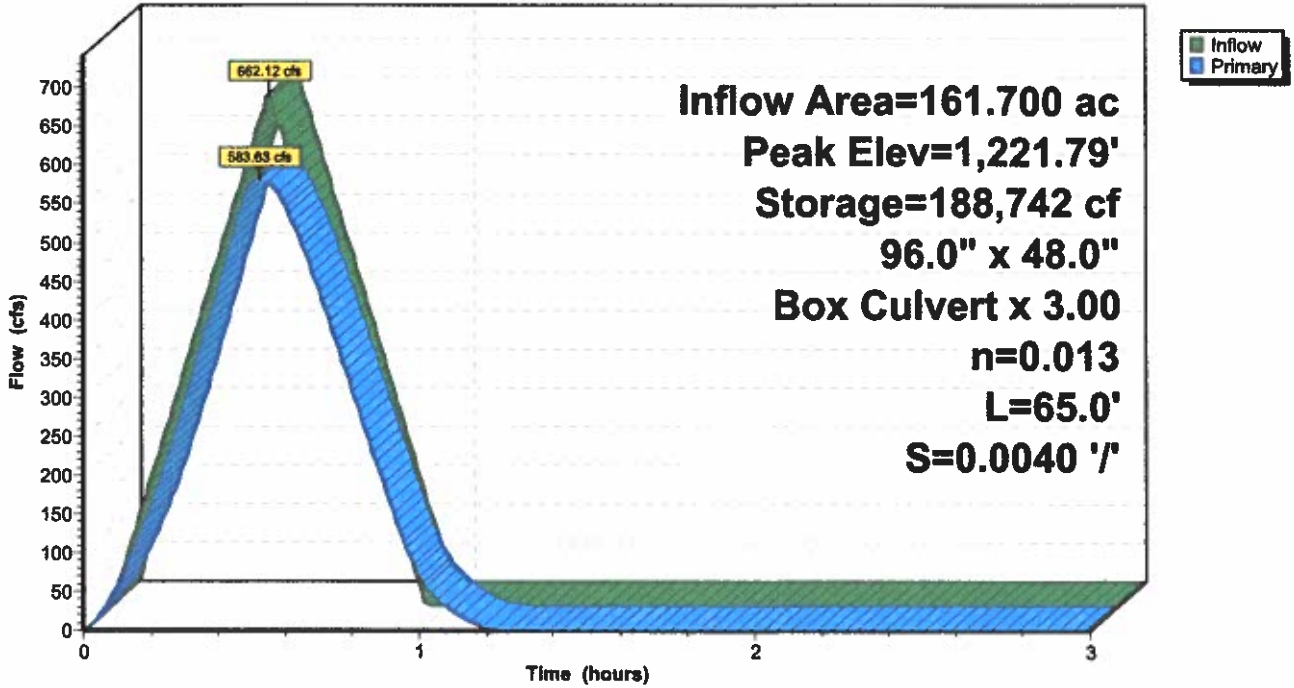

Pond 4P: Detention Pond

Stage-Discharge

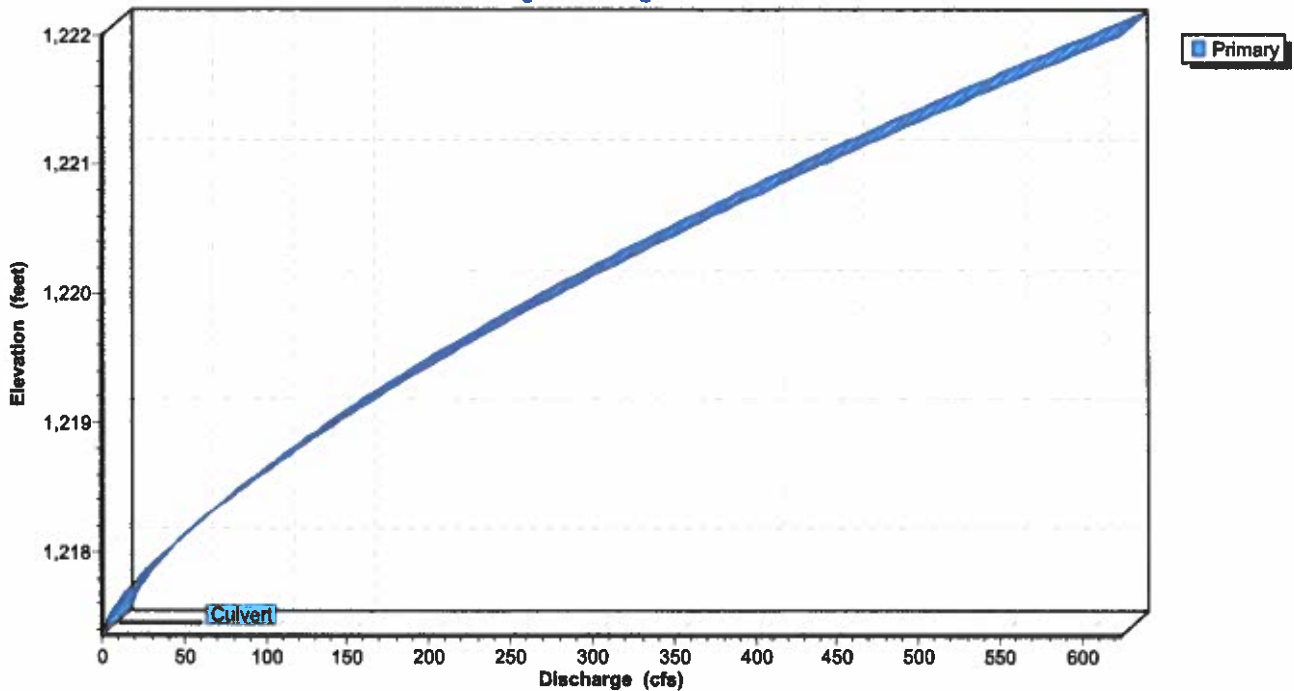

Pond 4P: Detention Pond

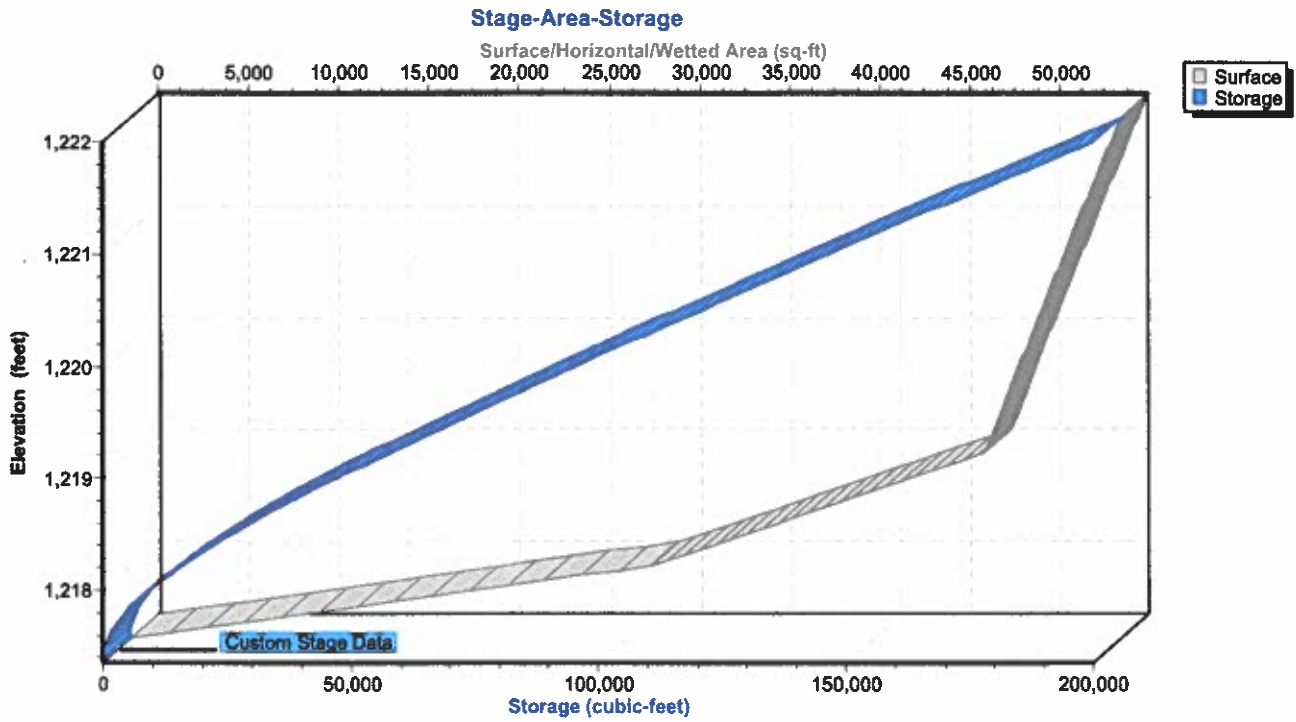

19013 Pond

Oklahoma Zone II 100-Year Duration=28 min, Inten=5.92 in/hr

Prepared by Windows User

Printed 2/26/2019

HydroCAD® 10.00-15 s/n 07286 © 2015 HydroCAD Software Solutions LLC

Page 11

Hydrograph for Pond 4P: Detention Pond

Time (hours)	Inflow (cfs)	Storage (cubic-feet)	Elevation (feet)	Primary (cfs)
0.00	0.00	0	1,217.36	0.00
0.10	142.77	16,649	1,218.24	59.71
0.20	285.55	54,631	1,219.16	162.27
0.30	428.32	101,373	1,220.12	296.30
0.40	571.10	147,999	1,221.03	444.97
0.50	618.69	186,997	1,221.76	577.55
0.60	475.92	177,818	1,221.59	545.79
0.70	333.14	145,526	1,220.98	436.79
0.80	190.37	105,376	1,220.20	308.56
0.90	47.59	60,633	1,219.28	178.42
1.00	0.00	20,552	1,218.36	70.84
1.10	0.00	4,768	1,217.82	23.64
1.20	0.00	450	1,217.50	3.90
1.30	0.00	7	1,217.37	0.09
1.40	0.00	0	1,217.36	0.00
1.50	0.00	0	1,217.36	0.00
1.60	0.00	0	1,217.36	0.00
1.70	0.00	0	1,217.36	0.00
1.80	0.00	0	1,217.36	0.00
1.90	0.00	0	1,217.36	0.00
2.00	0.00	0	1,217.36	0.00
2.10	0.00	0	1,217.36	0.00
2.20	0.00	0	1,217.36	0.00
2.30	0.00	0	1,217.36	0.00
2.40	0.00	0	1,217.36	0.00
2.50	0.00	0	1,217.36	0.00
2.60	0.00	0	1,217.36	0.00
2.70	0.00	0	1,217.36	0.00
2.80	0.00	0	1,217.36	0.00
2.90	0.00	0	1,217.36	0.00
3.00	0.00	0	1,217.36	0.00

19013 Pond

Oklahoma Zone II 100-Year Duration=28 min, Inten=5.92 in/hr

Prepared by Windows User

Printed 2/26/2019

HydroCAD® 10.00-15 s/n 07286 © 2015 HydroCAD Software Solutions LLC

Page 12

Stage-Discharge for Pond 4P: Detention Pond

Elevation (feet)	Primary (cfs)	Elevation (feet)	Primary (cfs)
1,217.36	0.00	1,219.96	272.85
1,217.41	0.72	1,220.01	280.31
1,217.46	2.23	1,220.06	287.83
1,217.51	4.28	1,220.11	295.41
1,217.56	6.72	1,220.16	303.06
1,217.61	9.48	1,220.21	310.76
1,217.66	12.50	1,220.26	318.53
1,217.71	15.75	1,220.31	326.35
1,217.76	19.19	1,220.36	334.24
1,217.81	22.81	1,220.41	342.18
1,217.86	26.59	1,220.46	350.19
1,217.91	30.52	1,220.51	358.25
1,217.96	34.59	1,220.56	366.37
1,218.01	38.78	1,220.61	374.55
1,218.06	43.10	1,220.66	382.79
1,218.11	47.53	1,220.71	391.08
1,218.16	52.07	1,220.76	399.43
1,218.21	56.73	1,220.81	407.83
1,218.26	61.48	1,220.86	416.29
1,218.31	66.34	1,220.91	424.81
1,218.36	71.30	1,220.96	433.38
1,218.41	76.35	1,221.01	442.00
1,218.46	81.50	1,221.06	450.68
1,218.51	86.74	1,221.11	459.42
1,218.56	92.07	1,221.16	468.20
1,218.61	97.49	1,221.21	477.05
1,218.66	102.99	1,221.26	485.94
1,218.71	108.58	1,221.31	494.89
1,218.76	114.25	1,221.36	503.88
1,218.81	120.01	1,221.41	512.94
1,218.86	125.84	1,221.46	522.04
1,218.91	131.76	1,221.51	531.19
1,218.96	137.76	1,221.56	540.40
1,219.01	143.83	1,221.61	549.65
1,219.06	149.98	1,221.66	558.96
1,219.11	156.21	1,221.71	568.32
1,219.16	162.51	1,221.76	577.73
1,219.21	168.88	1,221.81	587.18
1,219.26	175.33	1,221.86	596.69
1,219.31	181.85	1,221.91	606.25
1,219.36	188.44	1,221.96	615.85
1,219.41	195.10		
1,219.46	201.83		
1,219.51	208.63		
1,219.56	215.50		
1,219.61	222.44		
1,219.66	229.44		
1,219.71	236.52		
1,219.76	243.65		
1,219.81	250.86		
1,219.86	258.12		
1,219.91	265.45		

19013 Pond

Oklahoma Zone II 100-Year Duration=28 min, Inten=5.92 in/hr

Prepared by Windows User

Printed 2/26/2019

HydroCAD® 10.00-15 s/n 07286 © 2015 HydroCAD Software Solutions LLC

Page 13

Stage-Area-Storage for Pond 4P: Detention Pond

Elevation (feet)	Surface (sq-ft)	Storage (cubic-feet)	Elevation (feet)	Surface (sq-ft)	Storage (cubic-feet)
1,217.36	0	0	1,219.96	49,608	93,612
1,217.41	2,242	56	1,220.01	49,733	96,096
1,217.46	4,483	224	1,220.06	49,861	98,586
1,217.51	6,725	504	1,220.11	49,988	101,082
1,217.56	8,966	897	1,220.16	50,116	103,584
1,217.61	11,208	1,401	1,220.21	50,243	106,093
1,217.66	13,449	2,017	1,220.26	50,370	108,609
1,217.71	15,691	2,746	1,220.31	50,498	111,130
1,217.76	17,933	3,587	1,220.36	50,625	113,658
1,217.81	20,174	4,539	1,220.41	50,753	116,193
1,217.86	22,416	5,604	1,220.46	50,880	118,734
1,217.91	24,657	6,781	1,220.51	51,007	121,281
1,217.96	26,899	8,070	1,220.56	51,135	123,834
1,218.01	28,877	9,469	1,220.61	51,262	126,394
1,218.06	29,803	10,936	1,220.66	51,390	128,961
1,218.11	30,730	12,450	1,220.71	51,517	131,533
1,218.16	31,656	14,009	1,220.76	51,644	134,112
1,218.21	32,582	15,615	1,220.81	51,772	136,698
1,218.26	33,508	17,268	1,220.86	51,899	139,290
1,218.31	34,435	18,966	1,220.91	52,027	141,888
1,218.36	35,361	20,711	1,220.96	52,154	144,492
1,218.41	36,287	22,502	1,221.01	52,282	147,103
1,218.46	37,213	24,340	1,221.06	52,412	149,720
1,218.51	38,140	26,224	1,221.11	52,543	152,344
1,218.56	39,066	28,154	1,221.16	52,673	154,975
1,218.61	39,992	30,130	1,221.21	52,803	157,612
1,218.66	40,918	32,153	1,221.26	52,933	160,255
1,218.71	41,845	34,222	1,221.31	53,064	162,905
1,218.76	42,771	36,337	1,221.36	53,194	165,561
1,218.81	43,697	38,499	1,221.41	53,324	168,224
1,218.86	44,623	40,707	1,221.46	53,454	170,894
1,218.91	45,550	42,961	1,221.51	53,585	173,570
1,218.96	46,476	45,262	1,221.56	53,715	176,252
1,219.01	47,242	47,608	1,221.61	53,845	178,941
1,219.06	47,366	49,973	1,221.66	53,975	181,637
1,219.11	47,491	52,345	1,221.71	54,106	184,339
1,219.16	47,616	54,723	1,221.76	54,236	187,047
1,219.21	47,740	57,106	1,221.81	54,366	189,762
1,219.26	47,865	59,497	1,221.86	54,496	192,484
1,219.31	47,989	61,893	1,221.91	54,627	195,212
1,219.36	48,114	64,295	1,221.96	54,757	197,947
1,219.41	48,238	66,704			
1,219.46	48,363	69,119			
1,219.51	48,487	71,541			
1,219.56	48,612	73,968			
1,219.61	48,737	76,402			
1,219.66	48,861	78,842			
1,219.71	48,986	81,288			
1,219.76	49,110	83,740			
1,219.81	49,235	86,199			
1,219.86	49,359	88,664			
1,219.91	49,484	91,135			

Channel Report

Box culvert from north: (2) 6'x3' RCB

Rectangular

Bottom Width (ft) = 12.00
Total Depth (ft) = 3.00

Invert Elev (ft) = 100.00
Slope (%) = 0.65
N-Value = 0.013

Calculations

Compute by: Known Q
Known Q (cfs) = 383.58

Highlighted

Depth (ft) = 2.42
Q (cfs) = 383.58
Area (sqft) = 29.04
Velocity (ft/s) = 13.21
Wetted Perim (ft) = 16.84
Crit Depth, Yc (ft) = 3.00
Top Width (ft) = 12.00
EGL (ft) = 5.13

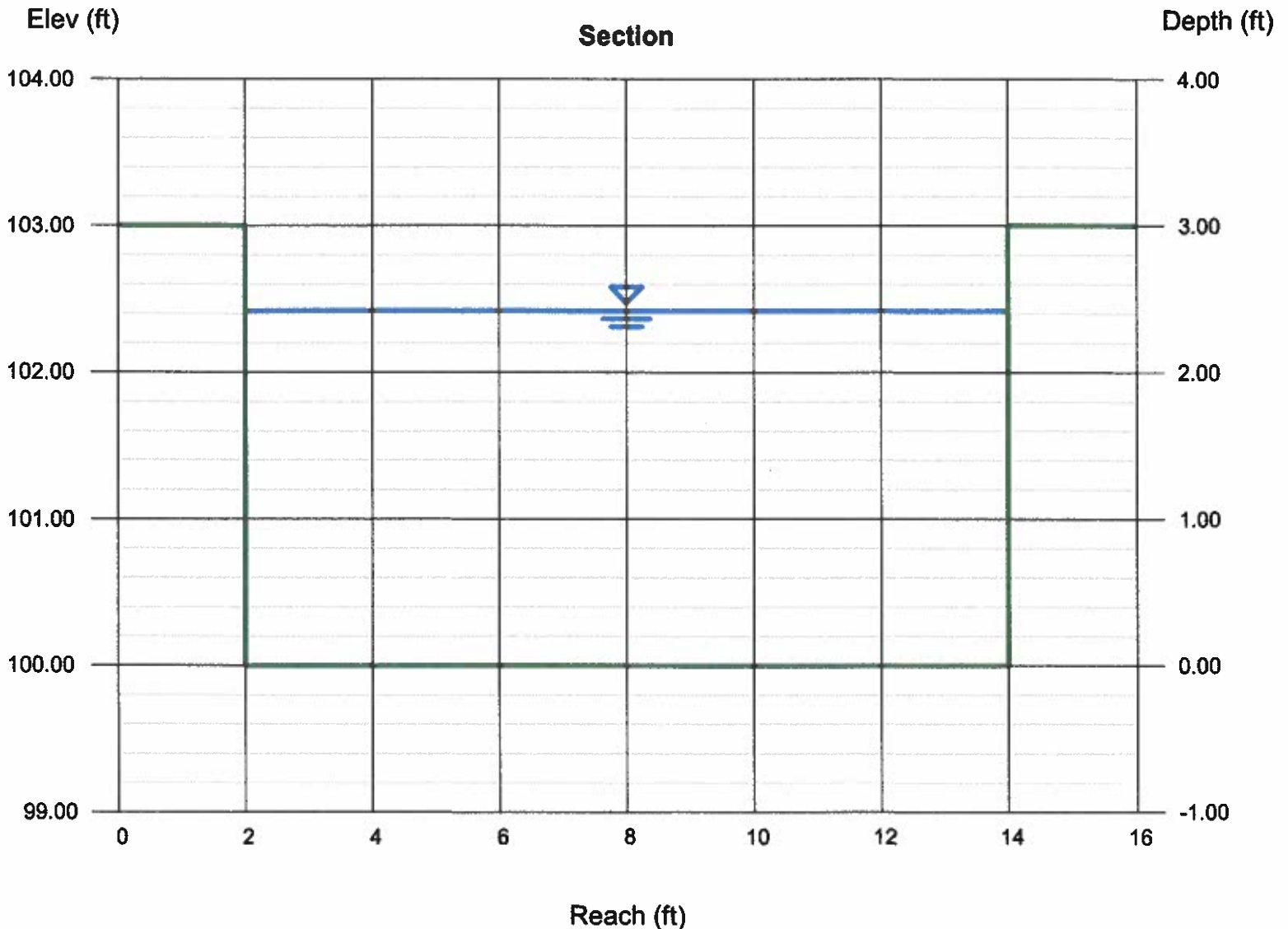

Channel Report

Box culvert from east: (2) 6'x3' RCB

Rectangular

Bottom Width (ft) = 12.00
Total Depth (ft) = 3.00

Invert Elev (ft) = 100.00
Slope (%) = 0.65
N-Value = 0.013

Calculations

Compute by: Known Q
Known Q (cfs) = 259.05

Highlighted

Depth (ft) = 1.86
Q (cfs) = 259.05
Area (sqft) = 22.32
Velocity (ft/s) = 11.61
Wetted Perim (ft) = 15.72
Crit Depth, Yc (ft) = 2.44
Top Width (ft) = 12.00
EGL (ft) = 3.95

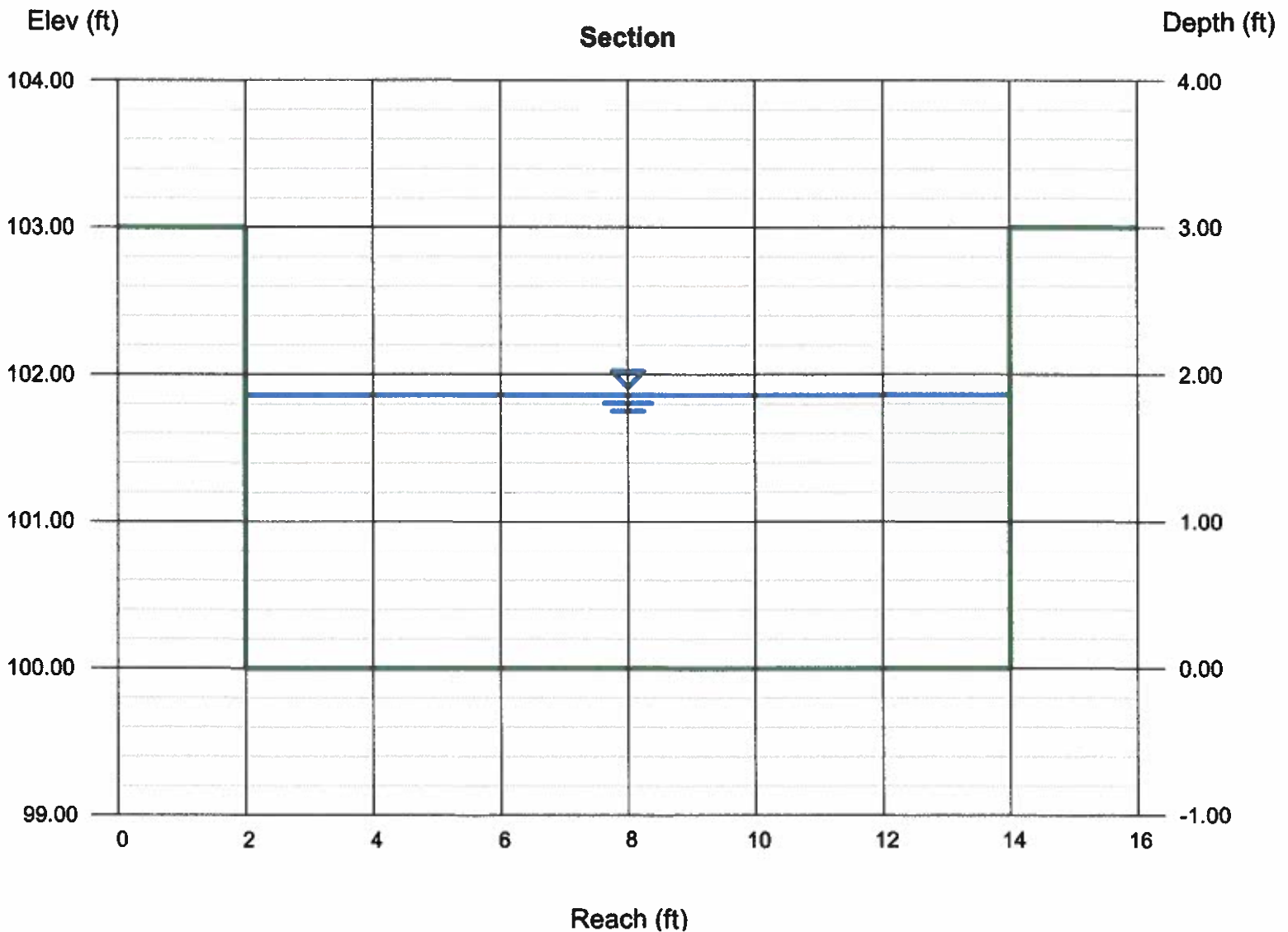

Channel Report

Channel from North

Trapezoidal

Bottom Width (ft) = 8.00
Side Slopes (z:1) = 1.00, 1.00
Total Depth (ft) = 3.00
Invert Elev (ft) = 100.00
Slope (%) = 0.65
N-Value = 0.013

Highlighted

Depth (ft) = 2.64
Q (cfs) = 383.58
Area (sqft) = 28.09
Velocity (ft/s) = 13.66
Wetted Perim (ft) = 15.47
Crit Depth, Yc (ft) = 3.00
Top Width (ft) = 13.28
EGL (ft) = 5.54

Calculations

Compute by: Known Q
Known Q (cfs) = 383.58

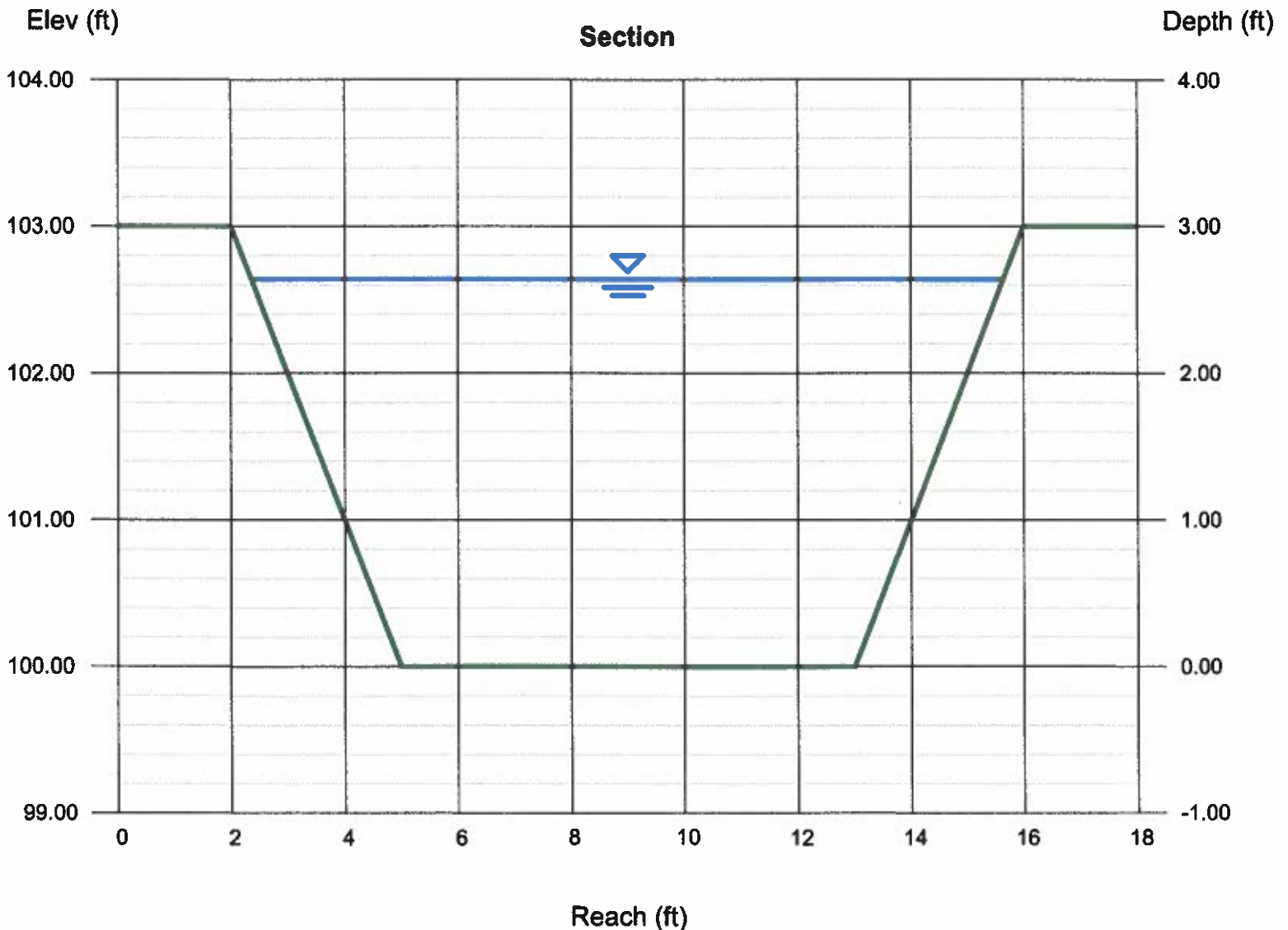

Channel Report

Concrete channel from East

Rectangular

Bottom Width (ft) = 20.00

Total Depth (ft) = 1.50

Invert Elev (ft) = 100.00

Slope (%) = 0.50

N-Value = 0.013

Calculations

Compute by: Known Q

Known Q (cfs) = 259.05

Highlighted

Depth (ft) = 1.40

Q (cfs) = 259.05

Area (sqft) = 28.00

Velocity (ft/s) = 9.25

Wetted Perim (ft) = 22.80

Crit Depth, Y_c (ft) = 1.50

Top Width (ft) = 20.00

EGL (ft) = 2.73

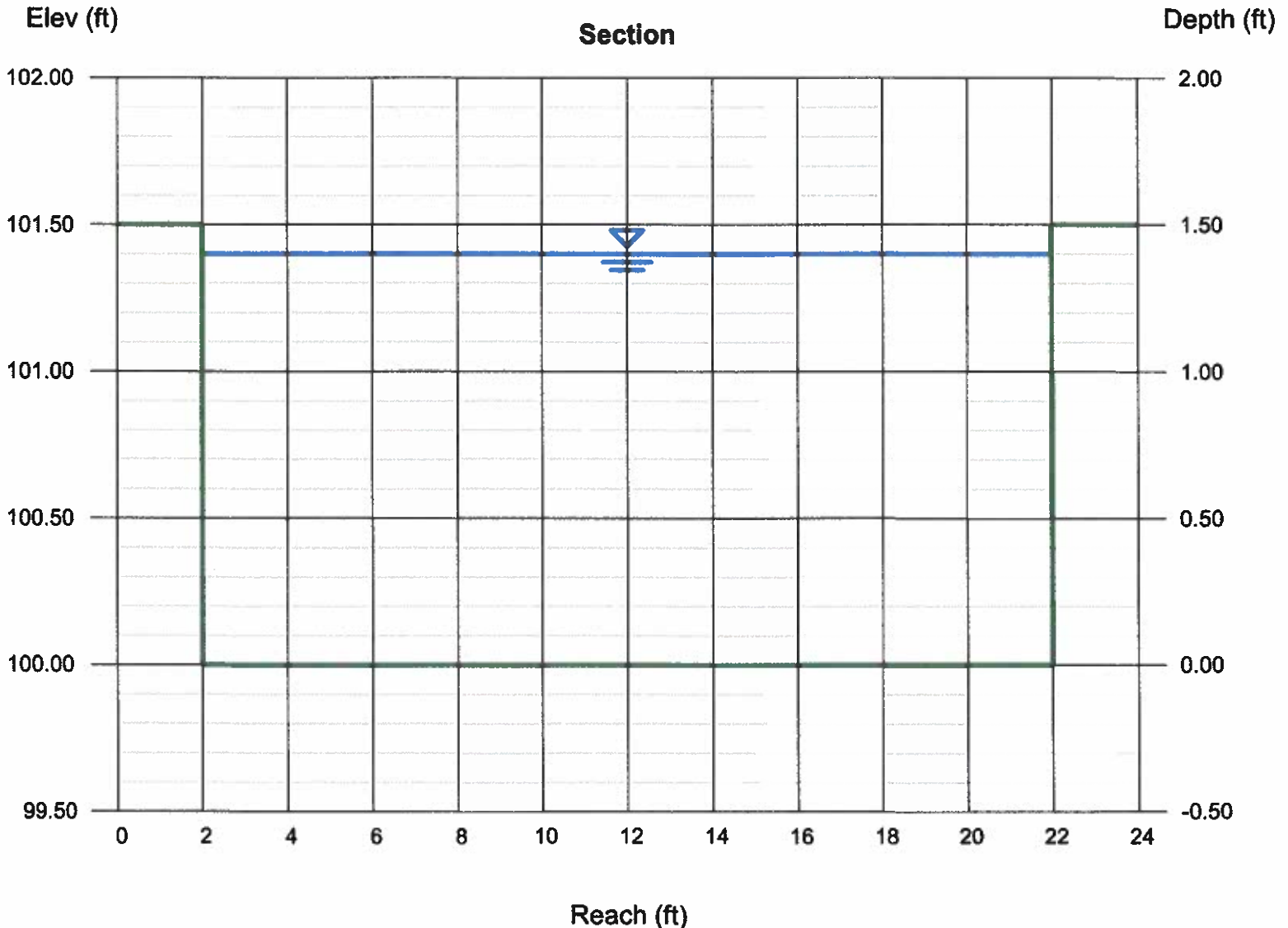

Existing Cassidy Cove 3 Topo

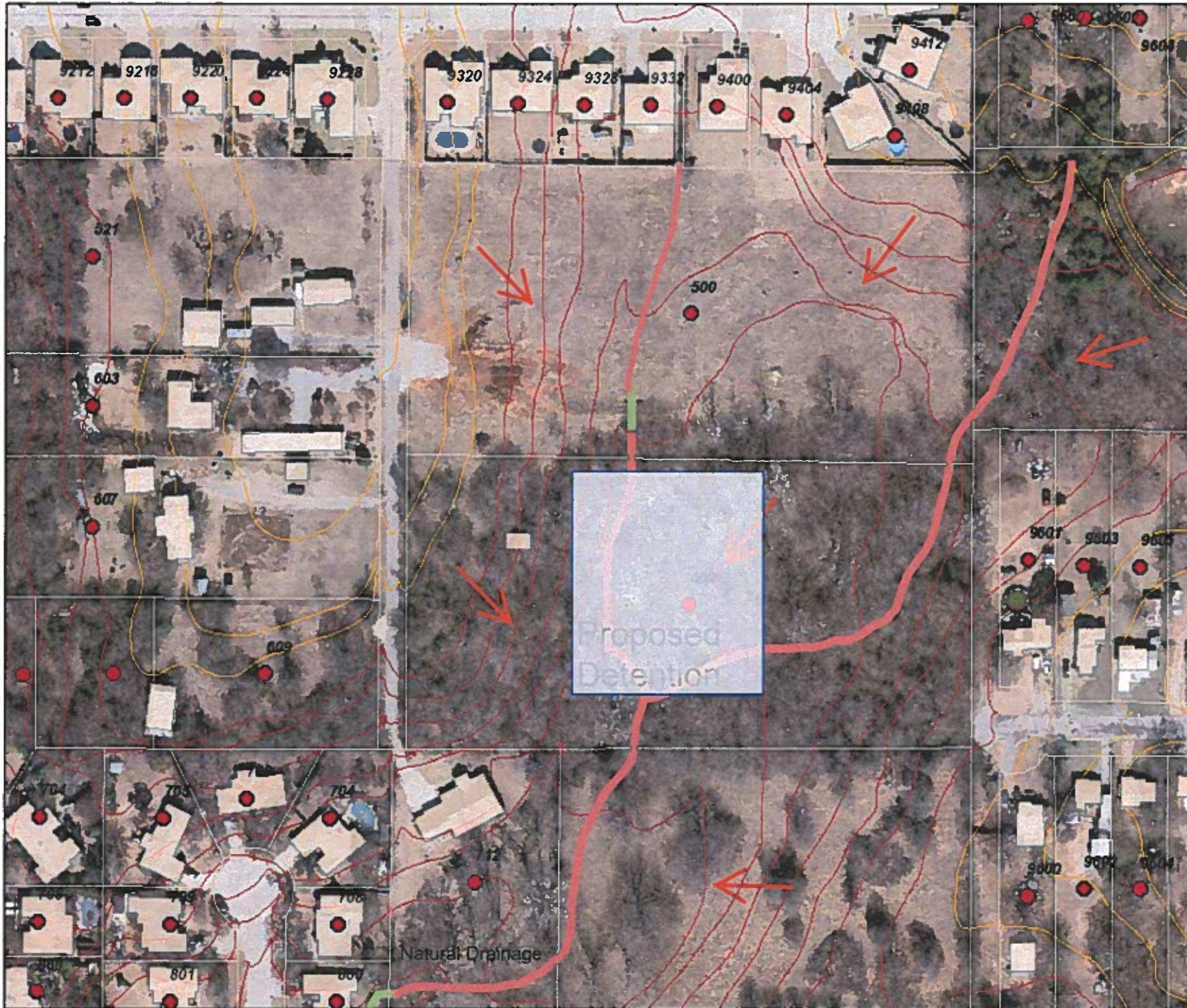

1 in = 188 ft
when printed actual size
on 8-1/2"x11" paper

DISCLAIMER
This map is a general information public resource. The City of Midwest City makes no warranty, representation or guarantee as to the content, accuracy, timeliness or completeness of any of the information provided on this map. Any party's use or reliance on this map, or any information on it, is at that party's own risk and without liability to the City of Midwest City, its officials or its employees for any discrepancies, errors or variances that may exist.

Existing Cassidy Cove 3 Topo

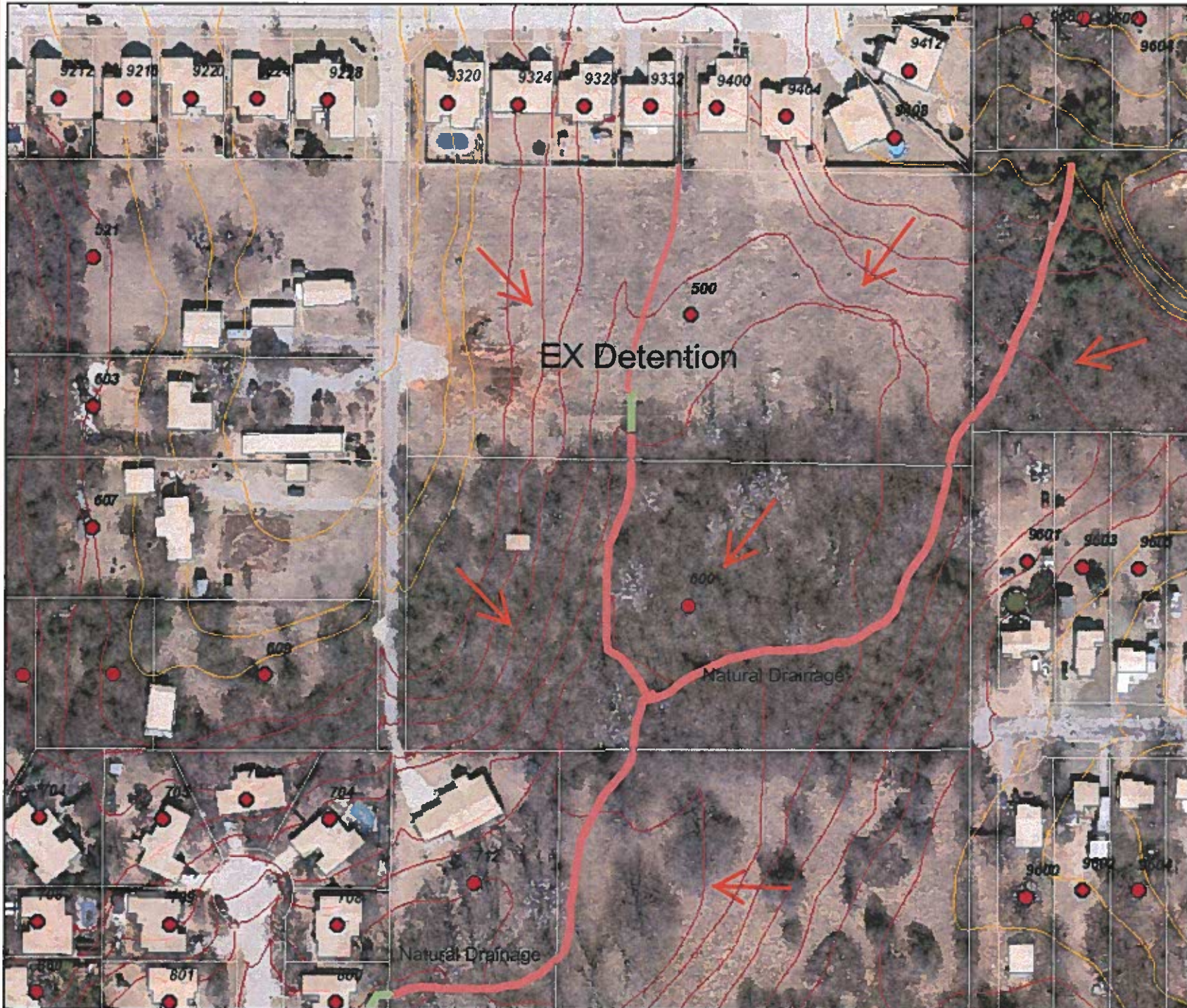

1 in = 188 ft
when printed actual size
on 8-1/2"x11" paper

DISCLAIMER
This map is a general information public resource. The City of Midwest City makes no warranty, representation or guarantee as to the content, accuracy, timeliness or completeness of any of the information provided on this map. Any party's use or reliance on this map, or any information on it, is at that party's own risk and without liability to the City of Midwest City its officials or its employees for any discrepancies, errors or variances that may exist.



Existing Tree Canopy

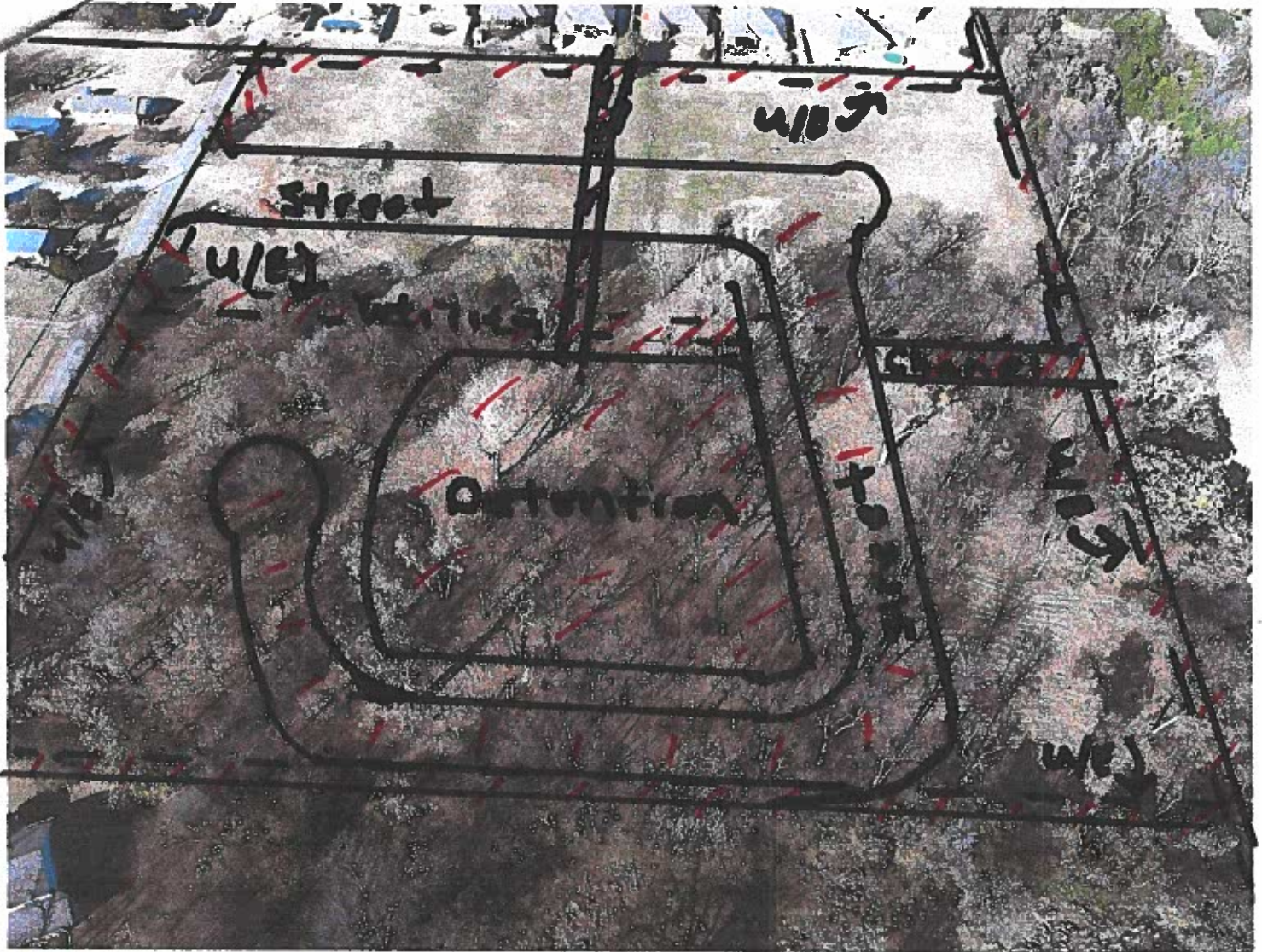

Tree Canopy Management Plan

 Indicates trees to be removed



The City of
MIDWEST CITY
 COMMUNITY DEVELOPMENT DEPARTMENT
 CURRENT PLANNING DIVISION

Applicant: Jim Campbell
 Phone Number: _____
 Address: 500/100 Davidson
Cassidy Cove Sec. III

Preliminary Plat Requirements/Checklist – Planning

- Lot to be subdivided is less than 5 acres
 Lot to be subdivided has an area of more than 10,000 square feet

38-48.2	Zoning Compliance	
38-48.2	All lots shall conform to zoning district compliance.	X
38-48.4	Lot Shape	
38-48.4 (A) (B)	Lots shall generally be rectangular in shape. Flag lots are prohibited. Irregular lots shall meet all width, frontage and setback requirements as required by the zoning ordinance.	X
38-48.5	Lot Lines	
38-48.5 (A) (1)	Side lot lines shall be at ninety degree angles or radial to street Right-of-Way lines to the greatest extent possible.	X
38-48.5 (B) (1)	All lot lines shall align along County, school district and other jurisdictional boundary lines.	X - All Mid-Okl Schools
38-48.6	Lot Orientation Restrictions	
38-48.6 (A)	No single-family, two-family or townhome lot shall front onto or have a driveway onto any Arterial Street.	X
38-48.6 (B)	Lots are prohibited from backing to local streets.	- Blk 2 Lots 9:10 Back onto Davidson
38-48.7	Limits-of-No-Access – shown on preliminary plat	
38-48.7 (A)(1)	Low Density lots shall not derive access from an Arterial Street.	X
38-48.7 (A)(2)	Lots facing Collector Streets should be minimized to the fullest extent.	X
38-48.8	Lot Frontages	
38-48.8 (A)(1)	Each lot shall have adequate access to a street by having frontage on a street that is not less than 35' at the street Right-of-Way line. This also applies to lots fronting onto an eyebrow or bulb portion of a cul-de-sac.	X
38-48.8(B)(1)(a)	For single-family, two-family and townhomes, double frontage lots are prohibited from backing or having the side facing onto an Arterial Street without appropriate screening.	N/A
38-48.8(B)(1)(b)	Where lots back or side onto an Arterial Street, no driveway access is allowed onto the Arterial Street.	N/A
38-48.8(B)(2)	For multifamily and nonresidential lots, if lots have frontage on more than one street, a front building line must be established for each street.	N/A
38-48.8(B)(3)	Residential lots should face the front of a similar lot, park or open space.	
38-48.10	Lot and Block Numbering	
38-48.10(A)	All lots within each phase of a development are to be numbered consecutively	X

Blk 2 Lots 9:10
 Back onto
 Davidson
 Waiver
 Requested



The City of
MIDWEST CITY
 COMMUNITY DEVELOPMENT DEPARTMENT
 CURRENT PLANNING DIVISION

	within each block. Each block shall have alpha or numeric designations.	
38-48.11	Building Lines	
	Building lines along all streets shall be shown on the Preliminary Plats and shall conform with the minimum setbacks for front, side and rear yards as required by the zoning district.	X
38-48.12	Block Requirements	
38-48.12(B)(1)	Blocks for residential uses shall not be longer than 1,800 feet measured along the center line of the block.	X
38-48.12(B)(2)	When a block exceeds 600 feet in length, the Planning Commission may require a dedicated easement not less than 15 feet wide and a paved crosswalk not less than 4 feet wide to provide pedestrian access across the block.	X
38-48.12(C)(1)	Blocks used for residential purposes should be of sufficient width to allow for two tiers of lots of appropriate depth.	X
38-48.12(C)(2)	Exceptions to the prescribed block width shall be permitted for blocks adjacent to major streets, railroads or waterways.	X
38-48.12(C)(3)	Blocks intended for business and industrial use should be of a width suitable for the intended use, with due allowance for off-street parking and loading facilities.	N/A
38-48.14	Subdivision Name Requirement	
38-48.14(A)(1)	New subdivisions shall be named so as to prevent conflict or "sound-alike" confusion with names of other subdivisions.	X
38-48.14(A)(2)	Subdivisions with similar names shall be located in proximity to each other.	X - Cassidy Cove III
38-49.3	Subdivision Amenities – Where amenities are proposed in conjunction with a development, such amenities shall be reviewed and approved in accordance with the following:	
38-49.3(A)	Preliminary plans and illustrations, along with a written statement of such concepts, shall be submitted for review and approval with the Preliminary Plat.	Detention info provided
38-49.3(B)	Plans for amenities shall then be incorporated into the screening plan and/or landscape plan for submittal as part of the construction plans.	N/A
38-49.3(C)	Lighting plans for all outdoor amenities	X
38-49.3(D)	Plans for structural elements shall be sealed by a licensed Professional Engineer and shall be considered for approval by the City.	
38-49.4	Design of Amenities	
38-49.4(A)(1)(a)	Entry features shall be constructed entirely on privately owned property and shall not suspend over a public Right-of-Way.	N/A - none proposed
38-49.4(A)(1)(b)	Minor elements of an entry feature may be placed within an entry street median upon Plat approval, provided that such street median is platted as a non-buildable lot and dedicated to a HOA for private ownership and maintenance.	N/A
38-49.4(A)(1)(c)	An entry feature having a water pond, fountain or other water feature shall only be allowed if approved by the Planning Commission and City Council during the plat review process.	N/A
38-	No entry feature, other than screening walls or extensions of screening walls,	N/A



The City of
MIDWEST CITY
 COMMUNITY DEVELOPMENT DEPARTMENT
 CURRENT PLANNING DIVISION

49.4(A)(1)(d)	may be constructed on any portion of a single-family, two-family or townhome	
38-49.4(A)(1)(e)	All such features shall be constructed on lots that are platted as "non-buildable" lots and dedicated to a HOA for private ownership and maintenance.	N/A
38-49.4(A)(2)	Entry features shall not encroach into the visibility triangle or otherwise impair pedestrian or vehicular visibility.	N/A
38-49.4(A)(3)	The maximum height for entry features and structures shall be the maximum height of the governing zoning district as measured from the nearest street or sidewalk grade.	N/A
38-49.4(B)	If private recreation facilities are provided, they shall be centrally located within the overall development to the greatest extent possible.	N/A - none proposed
38-49.4(C)	All outdoor amenities shall provide appropriate lighting.	Lighting prop. in detention area
38-49.4(D)	A detention or retention pond shall be considered an amenity if it meets the following design considerations:	NO
38-49.4(D)(1)	Located between the building and street or completely bounded by streets	X
38-49.4(D)(2)	Viewable from public space	X

38-49.4(D)(4)	Accessible by patrons	X
38-49.4(D)(5)	Seating area, public art or fountain	None proposed
38-49.4(D)(6)	One tree or planter at least 16 square feet for every 200 square feet of open space, and be located within or adjacent to the open space.	Existing trees will remain around perimeter of pond
38-50.2	Homeowners' Association (HOA) Applicability	
38-50.2(A)	Any one or more of the following elements created as part of a development shall require formation of a HOA prior to recordation of a final plat in order to maintain the amenity or facility:	Will Apply
38-50.2(A)(1)	Amenity	no
38-50.2(A)(2)	100-year Floodplain	no
38-50.2(A)(3)	Private streets	no
38-50.2(A)(4)	Thoroughfare screening	no
38-50.2(A)(5)	Detention or retention ponds	X yes
38-50.2(A)(6)	Private park	no
38-51.2	Applicability of Parks and Open Space Dedication	

This shall apply to all residential subdivision plats having a dwelling unit density of greater than one unit per net acre		X										
38-51.5(A)	The acreage to be contributed concurrent with the final approval by the City Council of any residential subdivision plat shall be determined by the following formula:	Parkland Review Committee voted to allow a fee in lieu of parkland dedication as the subdivision will generate much less than 2500 residents Allowed per Section 38-51.5 (c) subdivisions smaller than 2500										
	<table border="1"> <tr> <td>Two acres</td> <td>X (multiplied by)</td> <td>Each 1,000 persons projected to occupy the fully developed subdivision</td> <td>=</td> <td>Amount of land to be contributed</td> </tr> <tr> <td colspan="5" style="text-align: center;">Which is</td> </tr> </table>	Two acres	X (multiplied by)	Each 1,000 persons projected to occupy the fully developed subdivision	=	Amount of land to be contributed	Which is					
Two acres	X (multiplied by)	Each 1,000 persons projected to occupy the fully developed subdivision	=	Amount of land to be contributed								
Which is												



The City of
MIDWEST CITY
 COMMUNITY DEVELOPMENT DEPARTMENT
 CURRENT PLANNING DIVISION

	.002 acres	X (multiplied by)	Number of person per dwelling unit	X (multiplied by)	# of dwelling units projected for subdivision	=	Amount of land to be contributed	
38-51.6	Suitability of land							
38-51.6(A)(1)	The dedicated land should form a single parcel or tract of land at least 3 acres in size unless the Parkland Review Committee determines that a smaller tract would be in the public interest.							NO-park land committ Voted for fee in lieu
38-52.3	Design requirements for parks and open space							
38-52.3(A)	Parks and open spaces shall be bounded by a street or by other public uses.							N/A - fee in lieu
38-52.3(B)(1)	Single-family and two-family residential lots shall be oriented such that they front or side onto parks and open spaces but do not back to them.							N/A
38-52.3(B)(2)	Residential lots shall only be allowed to back onto a park or open space when:							↓
38-52.3(B)(2)(a)	A trail is provided within the related park or open space.							
38-52.3(B)(2)(b)	The sites physical character does not reasonably accommodate an alternative design or the layout of the subdivision complements the use of the use of park or open space (e.g., lots backing to a golf course.)							
38-52.3(C)(1)	A proposed development adjacent to a park or open space shall not be designed to restrict public visibility or reasonable access from other area developments.							
38-52.3(C)(2)	Street connections to existing or future adjoining subdivisions shall be required to provide reasonable access to parks and open space areas.							
38-52.3(D)(1)	Where a non-residential use must directly abut a park or open space area, the use shall be oriented such that it sides, and does not back onto the park or open space area if at all possible							
38-52.3(D)(2)	Nonresidential uses shall be separated from the park or open space by a minimum 6 foot tall decorative metal fence with an irrigated living screen.							
38-52.3(E)	Alleys should not be designed to encourage their use as a means of vehicular, bike or pedestrian travel to the park.							
38-52.3(F)(1)	Public access into parks and open spaces shall not be less than 50' in width at the public Right-of-Way line, at the street curb, and at any other public access point.							
38-52.3(F)(2)	Such access shall not be part of a residential lot or other private property.							
38-52.8	Hike-and-Bike Trail Requirements							
38-52.8(B)	Hike-and-Bike trails, especially those providing access too and along 100-year Floodplains and other open spaces, shall be in accordance with the following design criteria:							N/A - no proposed trails in the area
38-52.8(B)(1)	A minimum 30' wide level ground surface shall be provided for a 10' wide public hike-and-bike trail. The 30' wide level ground surface (compliant with ADA) may be provided within and/or outside of the 100-year floodplain.							
38-52.8(B)(2)	The Right-of-Way of a public street may count towards the 30' wide, ADA compliant level ground surface upon approval from the Director of Community Services.							N/A



The City of
MIDWEST CITY
 COMMUNITY DEVELOPMENT DEPARTMENT
 CURRENT PLANNING DIVISION

38-52.8(B)(4)	The hike-and-bike trail shall be designed to minimize visibility blind spots from public streets for public safety purposes.	N/A
38-52.8(C)(1)	The Director of Community Services shall have the authority to determine the placement of a public hike-and-bike trail at the time of the preliminary plat review and approval.	↓
38-52.8(C)(2)	The location of such trails shall be safe and economical.	
38-52.8(C)(3)	No development shall interrupt future trail routes or otherwise hinder efficient public access to or from an existing or future planned trail.	
38-52.8(D)(1)	The location of trails within developments adjacent to or within a 100-year Floodplain recognized on the Trails Master Plan shall be coordinated with the Director of Community Services and shall be staked in the field by the developer and approved by the Director of Community Services prior to the submittal of a preliminary plat.	
38-52.8(D)(2)	The location of the trail shall be specified on the preliminary plat as the approved location for the hike-and-bike trail, and an easement for such shall be shown on the preliminary plat and final plat for any portions of the trail that traverse private property.	
38-52.8(E)	When development is adjacent to an undeveloped property, a pedestrian access stub-out in conjunction with a street connection to the edge of the development shall be required to allow for future access between developments as indicated on the Trails Master Plan.	↓
38-53.4	Tree Canopy Management Plan	
38-53.4	A Tree Canopy Management Plan shall be required as part of the preliminary plat. This only applies to sites five acres or larger.	X
38-53.5(B)(1)	The applicant shall prepare a Tree Canopy Management Plan and shall submit the plan as part of the preliminary plat application.	X
38-53.5(B)(2)	Within the Tree Canopy Management Plan, the applicant shall provide the following information:	
38-53.5(B)(2)(a)	Pre-development tree canopy coverage (as determined by the City)	X
38-53.5(B)(2)(b)	Post-development tree canopy coverage (as determined by the applicant)	X
38-53.5(B)(2)(c)	Visual identification of tree canopy to be removed.	X
38-53.5(C)(1)	Tree Canopy Management Plan shall be reviewed by the Director of Community Development for compliance with all standards.	
38-53.5(C)(2)	After reviewing the Tree Canopy Management Plan, the Director of Community Development shall make a recommendation to the Planning Commission and City Council. The Director must act within 30 days of the official filing date of the preliminary plat application.	
38-53.6	Tree Preservation Requirements	
38-53.6(A)	Option A (Standard Option) – Only trees in the following areas may be removed:	



The City of
MIDWEST CITY
 COMMUNITY DEVELOPMENT DEPARTMENT
 CURRENT PLANNING DIVISION

38-53.6(A)(1)	The Tree Canopy or any tree located within any street Right-of-Way may be removed.	X
38-53.6(A)(2)	The Tree Canopy or any tree located within any area dedicated for water, wastewater, drainage and other similar infrastructure needs may be removed.	X
38-53.6(A)(3)	The Tree Canopy or any tree located within any area required by the subdivision ordinance for a site feature, such as a screening wall, may be removed.	X
38-53.6(B)	Option B (Alternative Compliance)	N/A
38-53.6(B)(1)	The applicant may elect to develop a site using the Residential Cluster Development option.	↓
38-53.6(B)(2)	In the design of the Tree Canopy Management Plan, if a Residential Cluster Development Option is used, only the Tree Canopy or trees within the designated open space areas shall be preserved.	
38-53.7	Tree Mitigation Plan – Required if trees are removed prior to approval of a Tree Canopy Management Plan	
38-53.7(B)(2)	Tree Mitigation Requirements:	
38-53.7(B)(2)(a)	The applicant shall calculate the area of Tree Canopy that should have been preserved under Option A or Option B.	
38-53.7(B)(2)(b)	The resulting calculation shall be the amount of Tree Canopy that shall be restored.	
38-53.7(B)(2)(c)	Replacement trees shall be required to cover an area equal to the calculated restoration area.	
38-53.7(B)(2)(d)	The applicant shall calculate the number of replacement trees needed to cover the calculated restoration area.	
38-53.7(B)(2)(e)	In calculating the area for replacement trees, the mature size of replacement trees shall be used.	
38-53.7(B)(2)(f)	In calculating the area for replacement trees, only large trees shall be used.	
38-53.7(B)(2)(g)	Tree Canopy coverage at maturity is to be obtained through the planting of 2.5 inch caliper trees at spacing that will meet the calculated restoration area.	
38-53.7(B)(2)(h)	Replacement trees shall be a minimum 2.5 inch caliper trees.	
38-53.7(B)(2)(i)	Replacement trees shall be planted at spacing that will meet the calculated restoration area.	
38-53.7(B)(2)(j)	The Tree Canopy Management Plan shall show graphically the location of each replacement tree.	
38-53.7(B)(2)(k)	The number of replacement trees shall be shown in a tabular format and indicated the tree species and area of coverage assumptions for each tree species at maturity.	
38-53.7(B)(2)(l)	Replacement trees shall be planted prior to the approval of a final plat.	
38-53.7(B)(3)	Alternative Tree Mitigation Requirements	↓



The City of
MIDWEST CITY
 COMMUNITY DEVELOPMENT DEPARTMENT
 CURRENT PLANNING DIVISION

Administrative		
One digital copy of the preliminary plat		X
Three 24x36 copies of the preliminary plat to scale		X
Name of subdivision centered at the top of the preliminary plat.		X
Name of city, county, state, section, township and range centered and printed at the top of the preliminary plat.		X
Name and address of the owner of record, the subdivider, the owners engineer and the registered surveyor preparing the plat.		X
Legal description of the property to be subdivided, including the acreage and number of proposed lots in the subdivision.		X
Key map showing the location of the property to be subdivided referenced to existing or proposed arterial streets or highways.		X

Preliminary Plat Requirements/Checklist - Zoning

5.14.1	Lot Variety Required (required for areas 5 acres or larger)	
5.14.1(A)	Applicability – This section only applies to single-family residential developments of 5 acres or larger.	X
5.14.1(B)(1)	15% of lots within a development shall be larger than the minimum lot size. Lots shall be increased at least 20% of the minimum lot size.	X
5.14.1(B)(2)	15% of lots within a development may be smaller than the minimum lot size. Lot sizes shall not be reduced greater than 20% of the minimum lot size.	N/A - none smaller than minimum
5.14.1(C)	Single-family lots shall not be smaller than 6,000 square feet.	X
5.14.1(D)	Lots of various sizes shall be evenly distributed throughout a development.	X

Additional Notes:



The City of
MIDWEST CITY
 COMMUNITY DEVELOPMENT DEPARTMENT
 ENGINEERING DIVISION

Applicant: CASSIDY GWE 3
 Phone Number: _____
 Address: _____

Preliminary Plat Requirements/Checklist - Engineering

The preliminary plat shall be accompanied by a statement signed by the registered engineer preparing the plat that he has, to the best of his ability, designed the subdivision in accordance with the latest subdivision regulations and in accordance with the ordinances and regulations governing the subdivision of land.

38-18	Preliminary Plat:	
Administrative	North arrow, scale, date, and site location map	✓
Administrative	The total number of lots	✓
Administrative	The total area of development	✓
Administrative	The location of proposed lots, areas in Acres and Square Feet, and dimensions.	✓
Administrative 38-42.3(b)(3)	The location of property lines, existing easements, buildings, fences, cemeteries or burial grounds, and other existing features within the area to be subdivided and similar facts regarding existing conditions on immediately adjacent property.	✓
Administrative 38-42.3(b)(3)	The location of any natural features such as water courses, water bodies, flood hazard areas, tree masses, steep slopes, or rock outcroppings within the area to be subdivided and similar facts regarding existing conditions on immediately adjacent property.	✓
Administrative 38-42.3(b)(3)	The location, width, and name of all existing or platted streets or other public ways (i.e. railroad and state-owned) within or immediately adjacent to the tract.	✓
Administrative	The location of all existing or abandoned oil or gas wells, oil or gas pipelines and other appurtenances associated with the extraction, production and distribution of petroleum products and all related easements on the site or on immediately adjacent property.	✓
13-18.2(c)	The applicant shall furnish with the application to the city a current title commitment issued by a title insurance company authorized to do business in Oklahoma, a title opinion letter from an attorney licensed to practice in Oklahoma, or some other acceptable proof of ownership, identifying all persons having an ownership interest in the property subject to the preliminary plat.	✓
Administrative	The legal metes and bounds of the property being developed.	✓
13-69.7(1)	The area of the preliminary drainage plan in acres shown at points where storm water enters and leaves the proposed subdivision, and where drainage channels intersect roadways and at junction points.	✓
13-69.7(3)	The location, size, and type of existing and proposed storm water control facilities including storm sewers, inlets, culverts, swales, channels and retention or detention ponds and areas. The approximate area in acres served by said facilities shall be shown.	✓



The City of
MIDWEST CITY
 COMMUNITY DEVELOPMENT DEPARTMENT
 ENGINEERING DIVISION

13-69.7(4)	Special structures such as dams, spillways, dikes or levees.	✓
Administrative	Location of Floodplain if adjacent or within development	✓
Administrative	Location of Wetlands if adjacent or within development. If so, the developer is required to notify the Army Corp of Engineers.	✓
Administrative 38-43.3(a)(1)	Show the location and size of water mains.	✓
Administrative 38-43.3(a)(1)	Show the location and size of wastewater mains.	✓
Administrative 38-43.3(a)(2)	Show the location and specifications for fire hydrant systems.	✓
Administrative	Finish floor elevations for all pad sites	✓
Administrative 13-69.7(2)	Drainage arrows on all lots showing the final grading and where the water will drain	✓
Administrative 38-54.3(c)(1) 38-54.3(d)(1) 38-54.4	Required retaining walls and retaining wall easements	✓
Administrative	Existing contours with intervals not to exceed two (2) feet referenced to a United State Geological Survey or Geodetic Survey bench mark or monument.	✓
Administrative	Show the proposed street layout and right of ways.	✓
38-45.4(c)	All existing arterial streets and such collector and local streets as may be necessary for convenience of traffic circulation and emergency ingress and egress.	✓
38-45.4(d)	All access points to existing roadways and be of the required number.	✓
38-45.4(e)	The development shall have two (2) connections to adjacent properties.	X
38-45.4(n)	The names of all new proposed streets.	✓
38-45.4(o)	The development shall not have any proposed cul-de-sacs longer than five hundred (500) feet in length	✓
38-47	The location and size of all proposed pedestrian crosswalks, bike trails, horse trails, or other supplementary movement systems.	✓
38-18.2(a)(1) 38-44.3(a)(2)	Preliminary stormwater management plan (SWMP)	✓
38-44.3(e)(1)	A digital copy of the preliminary SWMP shall be submitted along with the preliminary plat.	
38-44.3(e)(2)	The preliminary SWMP shall be labeled as "Preliminary"	
38-44.3(e)(3)	The preliminary SWMP shall be signed, sealed, and dated by the professional engineer (P.E.) or shall contain a statement showing the professional engineer's name and license number and affirming the preliminary SWMP was prepared under the direction of the engineer and that the plan is preliminary	



The City of
MIDWEST CITY
 COMMUNITY DEVELOPMENT DEPARTMENT
 ENGINEERING DIVISION

38-44.3(b)(3)	If no preliminary drainage plan is required [only upon city engineer's approval, see 38-44.44 (b)(3)]: show existing drainage patterns, runoff coefficients, and the proposed changes to these items (before and after development)	
38-44.3(c)	The preliminary SWMP must comply with the Engineering Standards Manual and construction details and the Midwest City Code of Ordinances (e.g. chapters 13 and 43), including control/sediment plans	
38-18.2(a)(2) 38-44.4(a)(2)	Preliminary drainage plan	✓
13-69.7(1)	The area of the preliminary drainage plan in acres shown at points where storm water enters and leaves the proposed subdivision, and where drainage channels intersect roadways and at junction points.	✓
13-69.7(3)	The location, size, and type of existing and proposed storm water control facilities including storm sewers, inlets, culverts, swales, channels and retention or detention ponds and areas. The approximate area in acres served by said facilities shall be shown.	✓
13-69.7(4)	Special structures such as dams, spillways, dikes or levees.	✓
38-44.4(c)(1)	The preliminary drainage plan shall show the watershed affecting the development and how the runoff from the fully-developed watershed will be conveyed to, through, and from the development.	✓
38-44.4(c)(2)	The preliminary drainage plan must comply with the Engineering Standards Manual and construction details and the Midwest City Code of Ordinances (e.g. chapters 13 and 43)	✓
38-44.4(d)(1)	Three (3) paper copies of the preliminary drainage plan	✓
38-44.4(d)(2)	The preliminary drainage plan shall be labeled as "Preliminary"	✓
38-44.4(d)(3)	The preliminary drainage plan shall be stamped by and dated by the engineer, professional	✓
38-44.5	If the development proposed is adjacent to or within the 100-year floodplain the following are required:	✗
38-44.5(a)	No Development within a floodway.	
38-44.5(b)	All 100-year floodplains shall be maintained in an open natural condition	
38-44.5(b)(3)(a)	The 100-year floodplain shall be dedicated on the final plat to the city as a single lot or may be owned and maintained by an HOA	
38-44.5(b)(3)(b)	No portion of a single-family or two-family residential lot shall exist within the 100-year floodplain	
38-44.5(b)(3)(c)	A fifteen-foot wide maintenance easement adjacent to the floodway	
38-44.5(b)(3)(e)	All streets adjacent to a 100-year floodplain shall have a minimum ROW width of fifty (50) feet.	
38-44.5(b)(3)(f)(2)	All streets adjacent to a 100-year floodplain shall have a minimum sixty (60) percent of the linear frontage	
38-44.5(b)(3)(f)(3)(a)	Not more than one (1) cul-de-sac in a row adjacent to 100-year floodplain	



The City of
MIDWEST CITY
 COMMUNITY DEVELOPMENT DEPARTMENT
 ENGINEERING DIVISION

38-44.5(b)(3)(f)(2)(b)(1)	A minimum fifty (50) percent of an adjacent cul-de-sac bulb shall be open to the 100-year floodplain and no residential lot shall encroach within the area between this line and the major creek.	
38-44.5(b)(3)(f)(2)(b)(2)	An entry monument(s) or feature(s) as well as landscaping shall be provided at the end of the cul-de-sac and a pathway of a minimum twelve (12) feet in width shall be provided to the major creek	
38-18.2(a)(3) 38-43.3	Preliminary utility plan	✓
Administrative	The preliminary utility plan shall show the location and width of all adjacent utility easements	✓
38-38.43.2(2)	Width of all proposed utility easements	✓
38-43.3(a)(1)	The preliminary utility plan shall show the location and size of water mains.	✓
38-43.3(a)(1)	The preliminary utility plan shall show the location and size of wastewater mains.	✓
38-43.3(a)(2)	The preliminary utility plan shall include plans and specifications for fire hydrant systems.	✓
38-43.4(b)	All water and wastewater utilities including connections within the ROW or easements shall be vested to the city.	✓
38-43.4(d)	No utility or service lines shall cross another lot.	✓
38-43.4(e)	Any utility adjacent to non-city government roads shall be constructed outside that ROW and in a separate easement unless agreed upon by non-city owner and Midwest City	✓
38-18.2(a)(5)	Preliminary site development plan	✓
Administrative	Finish floor elevations for all pad sites	
Administrative 13-69.7(2)	Drainage arrows on all lots showing the final grading and where the water will drain (not to drain over more than adjacent lot)	
Administrative 38-54.3(c)(1) 38-54.3(d)(1) 38-54.4	Required retaining walls and retaining wall easements	
Administrative	Existing contours with intervals not to exceed two (2) feet referenced to a United State Geological Survey or Geodetic Survey bench mark or monument.	
38-18.2(a)(6)	Street layout plan	✓
Administrative	The classification of every street within or adjacent to the development.	
38-45.4(b)	The streets within the development shall conform to the city's comprehensive plan.	
38-45.4(c)	The proposed street system shall extend all existing arterial streets and such collector and local streets as may be necessary for convenience of traffic circulation and emergency ingress and egress.	
38-45.4(d)	The street layout plan shall show all access points to existing roadways and be of the required number.	



The City of
MIDWEST CITY
 COMMUNITY DEVELOPMENT DEPARTMENT
 ENGINEERING DIVISION

38-45.4(e)	The street layout plan shall have two (2) connections to adjacent properties.	
38-45.4(n)	The street layout plan will have the names of all new proposed streets.	
38-45.4(o)	The street layout plan shall not have any proposed cul-de-sacs longer than five hundred (500) feet in length	
38-47	The location, size, and easements of all proposed pedestrian crosswalks, bike trails, horse trails, or other supplementary movement systems.	
38-18.2 (a) (7)	Street signage and striping plan	✓
Administrative	Proposed signage of development	
Administrative	Proposed striping if required	
38-18.2 (a) (9)	Other plans	
Engineering Comments and Recommendations:		
Associated Departments (Fire, Stormwater, and Utilities) Comments and Recommendations:		

UTILITY PLAN

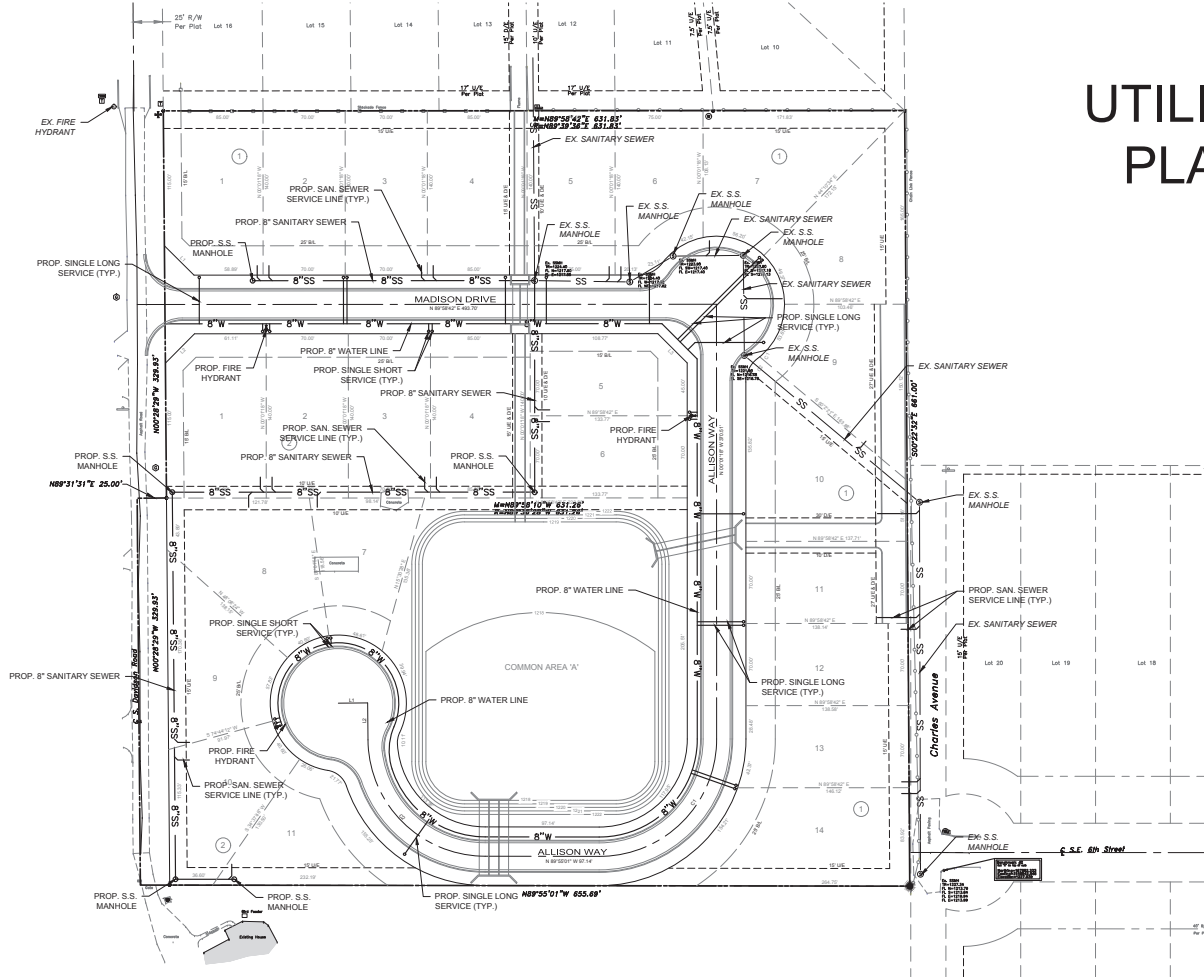

UTILITY NOTES

- A. CONTRACTOR SHALL REFER TO THE CONSTRUCTION DOCUMENTS INCLUDING BUT NOT LIMITED TO THE WRITTEN SPECIFICATIONS, CONSTRUCTION DRAWINGS, STORM WATER POLLUTION PLAN, AND GEOTECHNICAL REPORT.
- B. ALL CONSTRUCTION SHALL BE IN STRICT ACCORDANCE WITH THE OWNERS DESIGN GUIDELINES AND SPECIFICATIONS, AND WHERE APPLICABLE SHALL MEET THE REQUIREMENTS OF THE GOVERNING PERMITTING AUTHORITY HAVING JURISDICTION.
- C. CONTRACTOR IS RESPONSIBLE FOR THEIR OWN HORIZONTAL AND VERTICAL CONTROL. REFERENCE POINTS AND CONSTRUCTION STAKING AS INCIDENTAL TO THE PROJECT.
- D. THE CONTRACTOR SHALL FIELD VERIFY EXISTING ELEVATIONS/PROPERTY LINES/UTILITIES/DRAINAGE PRIOR TO CONSTRUCTION START.
- E. ALL WORK NOT CLASSIFIED AS A CONTRACT PAY ITEM SHALL BE CONSIDERED AS INCIDENTAL AND THE COST THEREOF SHALL BE INCLUDED IN THE UNIT PRICE BID FOR ITEMS WHICH ARE CLASSIFIED FOR PAYMENT.
- F. CONTRACTOR SHALL REFER TO THE ARCHITECTURAL AND MEP PLANS AND SPECIFICATIONS BEING A PART OF THE CONSTRUCTION DOCUMENTS FOR THE EXACT LOCATIONS AND DIMENSIONS OF ENTRY, EXIT PORCHES, PRECISE BUILDING DIMENSIONS, EXACT BUILDING UTILITY ENTRANCE, AND DOWNSPOUT LOCATIONS/SPECIFICATIONS/DETAILS.
- G. REFER TO ARCHITECTURE PLANS FOR SITE LIGHTING/POLE BASES AND ELECTRICAL CONDUIT PLACEMENT AND SPECIFICATIONS. POLE LOCATIONS ARE SHOWN ON THIS SHEET FOR REFERENCE ONLY. IT IS THE CONTRACTOR'S RESPONSIBILITY TO IDENTIFY AND ADJUST ANY CONSTRUCTED CONFLICTS WITH UNDERGROUND UTILITIES, SIDEWALKS, ETC.
- H. CONTRACTOR IS REQUIRED TO CALL ONE CALL AS WELL AS THE APPROPRIATE UTILITY COMPANY AT LEAST 48 HOURS BEFORE ANY EXCAVATION/CONSTRUCTION ACTIVITIES TAKE PLACE. IT SHALL BE THE RESPONSIBILITY OF THE CONTRACTOR TO RELOCATE ALL EXISTING UTILITIES WHICH ARE IN CONFLICT WITH PROPOSED IMPROVEMENTS.
- I. CONTRACTOR SHALL ENSURE ALL CONSTRUCTED UTILITIES MEET THE MINIMUM SEPARATION AND COVER REQUIREMENTS SET FORTH BY THE PROVIDER, FEDERAL/STATE/LOCAL REGULATIONS, OR SPECIFICATIONS. IN THE EVENT THERE IS A CONFLICT THE MOST STRINGENT SHALL APPLY.
- J. GENERAL CONTRACTOR TO PROVIDE 2'X2'X6" THICK CONCRETE APRON AT ALL CLEANOUTS, VALVES AND METERS OUTSIDE OF BUILDING.
- K. GENERAL CONTRACTOR SHALL BE RESPONSIBLE FOR ALL TAP AND THE ON FEES REQUIRED, AS WELL AS COST OF UNDERGROUND SERVICE CONNECTIONS TO THE BUILDINGS.
- L. THRUST BLOCKING SHALL BE PROVIDED AT ALL BENDS, TEES, AND FIRE HYDRANTS.
- M. DIMENSIONS SHOWN ARE TO CENTERLINE OF PIPE OR FITTING.
- N. ALL WATER AND SANITARY SEWER LEADS TO BUILDING SHALL END 5' OUTSIDE THE BUILDING LIMITS AS SHOWN ON PLAN AND SHALL BE PROVIDED WITH A TEMPORARY PLUG AT END.
- O. ALL FIRE HYDRANTS SHALL BE PROVIDED WITH AN APPROVED GATE VALVE A MAXIMUM OF 18" UNLESS OTHERWISE SPECIFIED BY CITY OFFICIAL FROM HYDRANT.
- P. CONTRACTOR SHALL COMPLY COMPLETELY WITH THE LATEST STANDARDS OF OSHA DIRECTIVES OR ANY OTHER AGENCY HAVING JURISDICTION FOR EXCAVATION AND TRENCHING PROCEDURES. THE CONTRACTOR SHALL USE SUPPORT SYSTEMS, SLOPING, BENCHING AND OTHER MEANS OF PROTECTION. THIS IS TO INCLUDE, BUT NOT LIMITED TO, ACCESS AND EGRESS FROM ALL EXCAVATION AND TRENCHING. CONTRACTOR IS RESPONSIBLE FOR COMPLYING WITH PERFORMANCE CRITERIA AS REQUIRED BY OSHA.
- Q. REFER TO FIRE PROTECTION SHEETS FOR LOCATION AND DETAIL OF FIRE LINE LEAD IN. FIRE LINE SHALL BE STUBBED UP 1' ABOVE FFE IN SPRINKLER ROOM.
- R. REFER TO PLUMBING SHEETS FOR LOCATION AND DETAILS OF SEWER, DOMESTIC, AND IRRIGATION CONNECTIONS.
- S. CONTRACTOR SHALL REFER TO IRRIGATION PLANS FOR ACTUAL LOCATION, SIZE, LENGTH AND DEPTH. TEMPORARILY PLUG BOTH ENDS. IRRIGATION CONTRACTOR WILL REMOVE TEMPORARY PLUGS, INSTALL LINES AND PROPERLY SEAL BOTH ENDS.
- T. THE FIRE DEPARTMENT CONNECTION (FDC) SHALL BE LOCATED ON THE STREET SIDE OF ANY STRUCTURE. THE FDC SHALL BE LOCATED AND ARRANGED SO THAT THE HOSE LINES CAN BE READILY ATTACHED TO THE INLETS WITHOUT INTERFERENCE FROM OBJECTS.
- U. IT IS THE CONTRACTOR'S RESPONSIBILITY TO COORDINATE THE EXTENSIONS OF ALL UTILITY SERVICE LINES TO THE MAIN UTILITY LINES.
- V. ALL CONDUIT SHALL BE SCHEDULE 40 PVC, UNLESS OTHERWISE NOTED.
- W. CONTRACTOR SHALL REFER TO LANDSCAPE AND IRRIGATION PLAN FOR LOCATION AND CONSTRUCTION DETAILS OF LANDSCAPING AND IRRIGATION.

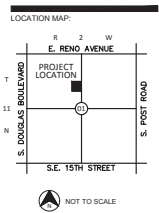

PROJECT:
CASSIDY COVE

MIDWEST CITY, OKLAHOMA

PROJECT NUMBER: 19013
 DRAWING DATE: 02.25.19
 ISSUE DATE: 02.25.19

SCALE:

SUBMITTAL:
PRELIMINARY PLAN SUBMITTAL

REVISIONS:

NO.	DATE	DESCRIPTION

THESE PLANS AND DRAWINGS ARE NOT TO BE REPRODUCED, CHANGED OR COPIED IN ANY FORM OR MANNER WITHOUT THE WRITTEN PERMISSION AND CONSENT OF CEDAR CREEK ENGINEERING + PLANNING + CONSULTING. THESE PLANS AND DRAWINGS ARE UNAUTHORIZED AND SHALL BE VOID IF ANY CHANGES ARE MADE FROM THESE PLANS WITHOUT THE WRITTEN PERMISSION AND CONSENT OF CEDAR CREEK ENGINEERING + PLANNING + CONSULTING. THE CONTRACTOR SHALL BE RESPONSIBLE FOR ALL CONSEQUENCES ARISING OUT OF SUCH CHANGES.

DRAWING TITLE:

OVERALL UTILITY PLAN

SHEET:
C1.00

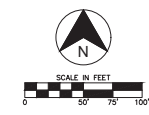



City Manager
100 N. Midwest Boulevard
Midwest City, OK 73110
ghenson@midwestcityok.org
Office: 405.739.1204/Fax: 405.739.1208
www.midwestcityok.org

Memorandum

TO: Honorable Mayor and Council

FROM: Guy Henson, City Manager

DATE: May 14, 2019

SUBJECT: Consider and adopt an ordinance providing for the issuance of General Obligation Bonds in the sum of Seventeen Million Two Hundred Fifty Thousand and no/100s Dollars (\$17,250,000.00) by the City of Midwest City, Oklahoma authorized at an election duly called and held for such purpose: Prescribing Form of Bonds; Providing for registration thereof; Providing for a system of registration for uncertificated registered public obligations; Providing levy of an annual tax for payment of principal and interest on the same; fixing other details of the issue; and Declaring an Emergency.

This action is necessary to issue the bonds. Staff recommends approval.

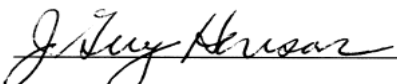

J. Guy Henson, AICP

**THE CITY COUNCIL OF THE CITY OF MIDWEST CITY, STATE OF OKLAHOMA,
MET IN REGULAR SESSION IN THE COUNCIL CHAMBERS AT THE CITY HALL, 100
NORTH MIDWEST BOULEVARD, IN SAID CITY ON THE 14TH DAY OF MAY, 2019, AT
6:00 O'CLOCK P.M.**

PRESENT:

ABSENT:

Notice of the regular meetings of the City Council for calendar year 2019 having been given in writing to the City Clerk of Midwest City, Oklahoma prior to December 15, 2018, and public notice having been posted in prominent public view at the City Hall, 100 North Midwest Boulevard, Midwest City, Oklahoma, twenty-four (24) hours prior to this meeting, excluding Saturdays, Sundays and legal holidays, all in compliance with the Oklahoma Open Meeting Act.

(OTHER PROCEEDINGS)

THEREUPON, an Ordinance was introduced which was read in full by the Clerk and considered by sections. Upon motion by _____, seconded by _____ the Ordinance was finally passed with the following vote:

AYE:

NAY:

And upon motion of _____, seconded by _____, the question of the emergency was ruled upon separately and approved by the following vote.

AYE:

NAY:

THEREUPON, the Ordinance was signed by the Mayor, attested by the Clerk, sealed with the seal of said municipality and is as follows:

ORDINANCE NUMBER _____

AN ORDINANCE PROVIDING FOR THE ISSUANCE OF GENERAL OBLIGATION BONDS IN THE SUM OF SEVENTEEN MILLION TWO HUNDRED FIFTY THOUSAND AND NO/100S DOLLARS (\$17,250,000.00) BY THE CITY OF MIDWEST CITY, OKLAHOMA AUTHORIZED AT AN ELECTION DULY CALLED AND HELD FOR SUCH PURPOSE; PRESCRIBING FORM OF BONDS; PROVIDING FOR REGISTRATION THEREOF; PROVIDING FOR A SYSTEM OF REGISTRATION FOR UNCERTIFICATED REGISTERED PUBLIC OBLIGATIONS; PROVIDING LEVY OF AN ANNUAL TAX FOR PAYMENT OF PRINCIPAL AND INTEREST ON THE SAME; FIXING OTHER DETAILS OF THE ISSUE; AND DECLARING AN EMERGENCY.

WHEREAS, on the 28th day of August, 2018, pursuant to notice duly given, an election was held in the City of Midwest City, State of Oklahoma, for the purpose of submitting to the registered, qualified electors of said City the question of the issuance of the bonds of said City in the following amounts:

\$5,560,000.00 of General Obligation Bonds by the City of Midwest City, Oklahoma, to provide funds (either with or without state or federal aid) for the purpose of acquiring, constructing, reconstructing, extending, enlarging, improving, and repairing the municipal water system within the City, all to be owned exclusively by said City, as authorized by Section 27, Article X of the Constitution and Statutes of the State of Oklahoma, and acts complementary, supplementary and enacted pursuant thereto; and

\$21,635,000.00 of General Obligation Bonds by the City of Midwest City, Oklahoma, to provide funds (either with or without state or federal aid) for the purpose of purchasing, constructing, equipping, improving, extending, renovating, repairing and beautifying public parks and parklands, cultural and recreational facilities, all to be owned exclusively by said City, as authorized by Section 27, Article X of the Constitution and Statutes of the State of Oklahoma, and acts complementary, supplementary and enacted pursuant thereto; and

\$10,490,000.00 of General Obligation Bonds by the City of Midwest City, Oklahoma, to provide funds (either with or without state or federal aid) for the purpose of acquiring, constructing, reconstructing, improving, remodeling, and repairing public safety buildings and facilities and acquiring necessary lands therefor and purchasing and installing public safety equipment all to be owned exclusively by said City, as authorized by Section 27, Article X of the Constitution and Statutes of the State of Oklahoma, and acts complementary, supplementary and enacted pursuant thereto; and

WHEREAS, as shown by the canvass of the returns by the County Election Board of Oklahoma County, Oklahoma, at said August 28, 2018 election there were cast by the registered, qualified electors of said City:

On the question of the issuance of said municipal water system bonds, 7090 votes, of which 4,665 were in favor of and 2,425 were cast against the issuance of said bonds, and 0 were mutilated, spoiled or not voted ballots; and

On the question of the issuance of said parks bonds, 7065 votes, of which 3,580 were in favor of and 3,485 were cast against the issuance of said bonds, and 0 were mutilated, spoiled or not voted ballots; and

On the question of the issuance of said public safety bonds, 6,694 votes, of which 3,690 were in favor of and 3004 were cast against the issuance of said bonds, and 0 were mutilated, spoiled or not voted ballots; and

WHEREAS, a lawful majority of the registered, qualified electors voting on such Proposition cast their ballots in favor of the issuance of all of said bonds and the issuance thereof has been duly authorized; and

WHEREAS, the City of Midwest City, Oklahoma has previously issued general obligation bonds for the above propositions consisting of the following:

Of the \$5,560,000.00 of General Obligation Bonds by the City of Midwest City, Oklahoma, to provide funds (either with or without state or federal aid) for the purpose of acquiring, constructing, reconstructing, extending, enlarging, improving, and repairing the municipal water system within the City, all to be owned exclusively by said City, as authorized by Section 27, Article X of the Constitution and Statutes of the State of Oklahoma, and acts complementary, supplementary and enacted pursuant thereto; the City has not issued any General Obligation Bonds previously; and

Of the \$21,635,000.00 of General Obligation Bonds by the City of Midwest City, Oklahoma, to provide funds (either with or without state or federal aid) for the purpose of purchasing, constructing, equipping, improving, extending, renovating, repairing and beautifying public parks and parklands, cultural and recreational facilities, all to be owned exclusively by said City, as authorized by Section 27, Article X of the Constitution and Statutes of the State of Oklahoma, and acts complementary, supplementary and enacted pursuant thereto, the City has previously issued bonds in the amount of \$4,345,000.00 in its April 1, 2019 issue; and

Of the \$10,490,000.00 of General Obligation Bonds by the City of Midwest City, Oklahoma, to provide funds (either with or without state or federal aid) for the purpose of acquiring, constructing, reconstructing, improving, remodeling, and repairing public safety buildings and facilities and acquiring necessary lands therefor and purchasing and installing public safety equipment all to be owned exclusively by said City, as authorized by Section 27, Article X of the Constitution and Statutes of the State of Oklahoma, and acts complementary, supplementary and enacted pursuant thereto, the City has previously issued bonds in the amount of \$7,710,000.00 in its April 1, 2019 issue; and

WHEREAS, The Council of the City of Midwest City, Oklahoma, pursuant to Title 62, Oklahoma Statutes 2011, Section 354, desires to issue at this time \$17,250,000.00 in General Obligation Bonds authorized at the August 28, 2018 election consisting of a combined issue of \$5,555,000.00 bonds for the purpose of acquiring, constructing, reconstructing, extending, enlarging, improving, and repairing the municipal water system within the City, all to be owned exclusively by said City; \$10,740,000.00 bonds for the purpose of purchasing, constructing, equipping,

improving, extending, renovating, repairing and beautifying public parks and parklands, cultural and recreational facilities, all to be owned exclusively by said City; and \$955,000.00 bonds for the purpose of acquiring, constructing, reconstructing, improving, remodeling, and repairing public safety buildings and facilities and acquiring necessary lands therefor and purchasing and installing public safety equipment all to be owned exclusively by said City.

BE IT ORDAINED BY THE COUNCIL OF THE CITY OF MIDWEST CITY, OKLAHOMA:

SECTION 1. That there are hereby ordered and directed to be issued the bonds of said City, in accordance with the form as hereinafter set out, in the aggregate amount of Seventeen Million Two Hundred Fifty Thousand and No/100s Dollars (\$17,250,000.00), which Bonds shall be designated "General Obligation Bonds, Series 2019A" (the "Bonds"), shall be dated June 1, 2019, and shall become due and payable and shall bear interest from their date until paid as follows:

<u>Maturing June 1</u>	<u>Principal Amount</u>	<u>Interest Rate</u>
2021	\$575,000.00	.000%
2022	\$725,000.00	.000%
2023	\$725,000.00	.000%
2024	\$725,000.00	.000%
2025	\$725,000.00	.000%
2026	\$725,000.00	.000%
2027	\$725,000.00	.000%
2028	\$725,000.00	.000%
2029	\$725,000.00	.000%
2030	\$725,000.00	.000%
2031	\$725,000.00	.000%
2032	\$725,000.00	.000%
2033	\$725,000.00	.000%
2034	\$725,000.00	.000%
2035	\$725,000.00	.000%
2036	\$725,000.00	.000%
2037	\$725,000.00	.000%
2038	\$725,000.00	.000%
2039	\$725,000.00	.000%
2040	\$725,000.00	.000%
2041	\$725,000.00	.000%
2042	\$725,000.00	.000%
2043	\$725,000.00	.000%
2044	\$725,000.00	.000%

Interest shall be payable semi-annually on the first day of June and December of each year, commencing on June 1, 2020. The Bonds are issuable as registered Bonds in denominations of \$1,000.00 or any whole multiple thereof.

The Bonds maturing in the years 2021 through 2029, inclusive, shall not be subject to redemption prior to maturity. The Bonds maturing in the years 2030 and thereafter shall be subject to redemption at the option of the City, in whole or in part, in inverse order of maturity and by lot within a maturity, on any date on or after June 1, 2029, at the principal amount thereof plus accrued interest to the date fixed for redemption.

Notice of any such redemption shall be sent by registered or certified mail not less than thirty (30) days nor more than sixty (60) days prior to the date fixed for redemption to the Registered Holder of each Bond to be redeemed at the address shown on the Registration Books of the City maintained by the Registrar or at such other address as is furnished in writing by such Registered Holder to the Registrar. When so called for redemption, this Bond will cease to bear interest on the specified redemption date, provided funds for redemption are on deposit at the place of payment at that time, and shall not be deemed to be outstanding.

SECTION 2. That each of said Bonds and the endorsements and certificates thereon shall be in substantially the following form:

Unless this Bond is presented by an authorized representative of The Depository Trust Company to the Registrar for registration of transfer, exchange or payment and any bond issued is registered in the name of Cede & Co., or such other name as requested by an authorized representative of The Depository Trust Company and any payment is made to Cede & Co., ANY TRANSFER, PLEDGE OR OTHER USE HEREOF FOR VALUE OR OTHERWISE BY OR TO ANY PERSON IS WRONGFUL since the registered owner hereof, Cede & Co., has an interest herein.

No. _____	UNITED STATES OF AMERICA STATE OF OKLAHOMA CITY OF MIDWEST CITY General Obligation Bond, Series 2019A Due June 1, _____	\$ _____
_____ %		CUSIP No.

KNOW ALL MEN BY THESE PRESENTS:

That the City of Midwest City, of Oklahoma County, Oklahoma, hereby acknowledges itself indebted to and for value received, promises to pay the principal amount set forth above to the person named below:

 CEDE & CO., INC.

or registered assigns, (hereinafter called the "Registered Holder"), for the bond number(s) set forth above, together with interest thereon at the rate specified hereon, from the date hereof until paid, payable semi-annually on the 1st day of June, and the 1st day of December, respectively, in each year, beginning June 1, 2020.

The principal of and interest on this Bond are payable in lawful money of the United States of America which, at the time of payment, shall be legal tender for the payment of public and private debts. Payments of interest hereon shall be paid by check of BancFirst, Oklahoma City, Oklahoma (herein called the "Bank") payable to the order of the Registered Holder and mailed to the address shown in the Registered Holder on or before the date on which each such payment is due. Payment of principal of this Bond shall be payable only upon surrender of this Bond to the Bank.

THE FULL FAITH, CREDIT, AND RESOURCES of said City are hereby irrevocably pledged to the payment of this Bond.

THIS BOND is one of an issue of like date and tenor, except as to date of maturity, rate of interest, and denomination, totaling the principal sum of Seventeen Million Two Hundred Fifty Thousand and No/100s Dollars (\$17,250,000.00) consisting of a combined issue of \$5,555,000 bonds for the purpose of acquiring, constructing, reconstructing, extending, enlarging, improving, and repairing the municipal water system within the City, all to be owned exclusively by said City; \$10,740,000.00 bonds for the purpose of purchasing, constructing, equipping, improving, extending, renovating, repairing and beautifying public parks and parklands, cultural and recreational facilities, all to be owned exclusively by said City; and \$955,000.00 bonds for the purpose of acquiring, constructing, reconstructing, improving, remodeling, and repairing public safety buildings and facilities and acquiring necessary lands therefor and purchasing and installing public safety equipment all to be owned exclusively by said City; all as approved at an election held on August 28, 2018; all pursuant to Section 27, Article X of the Constitution and statutes of the State of Oklahoma, and acts complementary, supplementary, and enacted pursuant thereto.

No person shall be entitled to any right or benefit provided in this Bond unless the name of such person is registered by the Bank as the Registrar of the City on the Registration Record. This Bond shall be transferable only upon delivery of this Bond to the Registrar, duly endorsed or accompanied by a written instrument of transfer in form satisfactory to the Bank, duly executed by the Registered Holder hereof or his attorney duly authorized in writing, and such transfer registered on the Registration Record. The Registrar shall not be required to make such transfer after the fifteenth (15) day preceding any interest payment date (the "Record Date") until after said interest payment date. The name of the Registered Holder endorsed hereon shall be deemed the correct name of the owner of this Bond for all purposes whatsoever. The Registrar will keep the Registration Record open for registration of ownership of registered Bonds during its business hours. In the event of a change of Registrar for any reason, notice thereof shall be mailed, by registered or certified United States Mail, postage prepaid, to the Registered Holder at the address shown in the Registration Record, and such notice shall be effective on the date of mailing and sufficient as to all persons.

Bonds of the issue of which this Bond is one, maturing in the years 2021 through 2029, inclusive, shall not be subject to redemption prior to maturity. Said Bonds maturing in the years 2030 and thereafter shall be subject to redemption at the option of the City, in whole or in part, in inverse order of maturity and by lot within a maturity, on any date on or after June 1, 2029, at the principal amount thereof plus accrued interest to the date fixed for redemption.

Notice of any such redemption shall be sent by registered or certified mail not less than thirty (30) days nor more than sixty (60) days prior to the date fixed for redemption to the Registered Holder of each Bond to be redeemed at the address shown on the Registration Books of the City maintained by the Registrar or at such other address as is furnished in writing by such Registered Holder to the Registrar. When so called for redemption, this Bond will cease to bear interest on the specified redemption date, provided funds for redemption are on deposit at the place of payment at that time, and shall not be deemed to be outstanding.

IT IS HEREBY CERTIFIED AND RECITED that all acts, conditions and things required to be done, precedent to and in the issuance of this Bond have been properly done, happened and been performed in regular and due form and time as required by law, and that the total indebtedness of said City, including this Bond, and the series of which it forms a part, does not exceed any constitutional or statutory limitation; and that due provision has been made for the collection of an annual tax sufficient to pay the interest on this Bond as it falls due and also to constitute a sinking fund for the payment of the principal hereof at maturity.

IN WITNESS WHEREOF, said City has caused this Bond to be signed by the Mayor, attested by its City Clerk, and sealed with the seal thereof this 1st day of June, 2019.

Mayor of the City of Midwest City, Oklahoma

Attest:

City Clerk, City of Midwest City, Oklahoma
(Seal)

AUTHENTICATION CERTIFICATE

This Bond is one of the Bonds of the issue described in the Transcript of Proceedings prepared for this Bond issue, and is one of the General Obligation Bonds, Series 2019A, of the City of Midwest City, Oklahoma.

Date of Registration and Authentication.

BancFirst

By: _____
Authorized Officer

FORM OF ASSIGNMENT

The following abbreviations, when used in the inscription on the face of this Bond, shall be construed as though they were written out in full according to applicable laws or regulations:

TEN COM-- as tenants in common
TEN ENT-- as tenants by the entireties
JT TEN-- as joint tenants with the right of survivorship
 and not as tenants in common

UNIF GIFT MIN ACT-- _____ Custodian for _____ under Uniform
 (Cust) (Minor)
 Gifts to Minors Act of Oklahoma

Additional abbreviations may also be used though not in above list.

ASSIGNMENT

FOR VALUE RECEIVED, the undersigned hereby sells, assigns and transfers unto _____

(Please insert Social Security or Taxpayer identification number of assignee) _____

(Please Print or Typewrite Name and Address of Assignee)

the within Bond, and all rights thereunder, and hereby does irrevocably constitute and appoint _____

attorney to transfer the within Bond on
the books kept for registration thereof, with full power of substitution in the premises.

Dates: _____

(Signature guaranty)

NOTICE: The signature to this assignment must correspond with the name as it appears upon the face of the within Bond in every particular, without alteration or enlargement or any change whatever.

Legal Opinion

(ENDORSEMENT NO. 2)

Form of certificate by the City Treasurer to be endorsed on each Bond.

STATE OF OKLAHOMA)
) ss.
COUNTY OF OKLAHOMA)

I, the undersigned, the duly qualified and acting Treasurer of the within named City in said County and State, hereby certify that I have duly registered the within Bond in my office on this 1st day of June, 2019.

WITNESS my hand the date above written.

City Treasurer

(ENDORSEMENT NO. 3)

Certificate of approval by the Attorney General to be endorsed on each Bond.

STATE OF OKLAHOMA
OFFICE OF THE ATTORNEY GENERAL
BOND DEPARTMENT _____, 2019.

I HEREBY CERTIFY that I have examined a certified copy of the record of proceedings taken preliminary to and in the issuance of the within Bond; that such proceedings and such Bond show lawful authority for the issue and are in accordance with the forms and method of procedure prescribed and provided by me for the issuance of Bonds of like kind and that said Bond is a valid and binding obligation, according to its tenor and terms and, under the provisions of Title 62, Oklahoma Statutes 2011, Section 11, 13, and 14, requiring the certificate of the Bond Commissioner of the State of Oklahoma thereon, is incontestable in any court in the State of Oklahoma unless suit thereon shall be brought in a court having jurisdiction of the same within thirty days from the date of this approval of said Bond appearing in the caption hereto.

**Attorney General, Ex-Officio Bond
Commissioner of the State of Oklahoma**

SECTION 3. That each of said Bonds shall be signed by the Mayor and the corporate seal of the City affixed thereto and attested by the City Clerk of the City; that such officers be and hereby are authorized and directed to cause said Bonds to be prepared and to execute the same for and on behalf of the City, have the same registered by the Treasurer, endorsed by the District Attorneys and County Clerks and presented to the Attorney General, Ex-Officio Bond Commissioner, together with a certified transcript of all proceedings had in connection with their issue for his approval and

endorsement; that thereafter said Bonds shall be delivered to the purchaser upon payment of the purchase price thereof, which shall not be less than par and accrued interest. The proceeds derived from the sale of said Bonds shall be placed in a special fund and used solely for the purposes set out in the Bond in Section 2 hereof.

SECTION 4. Whenever any registered Bond or Bonds shall be exchanged for another registered Bond or Bonds of different denomination, the Registrar shall cancel the Bond or Bonds surrendered in such exchange on the face thereof and on the Registration Record. If the supply of registered Bonds for making exchanges shall have been exhausted, the Registrar shall cause additional registered Bonds to be prepared, at the expense of the City. The City covenants that upon request of the Registrar, its appropriate officers promptly will execute such additional registered Bonds on behalf of the City.

SECTION 5. The Registrar for all registered Bonds issued pursuant to this Ordinance shall be BancFirst, Oklahoma City, Oklahoma, which shall maintain a Registration Record for the purpose of registering the name and address of the Registered Holder of each registered Bond. The Registrar will keep the Registration Record open for registrations during its business hours. In the event of a change of Registrar, notice thereof shall be mailed, registered or certified United State Mail, postage prepaid, to the Registered Holder of each registered Bond. The name and address of the Registered Holder as the same appear on the Registration Record shall be conclusive evidence to all persons and for all purposes whatsoever and no person other than the Registered Holder shown on the Registration Record shall be entitled to any right or benefit in relation to the Bond so registered; provided, that the foregoing shall not apply to any successor by operation of law of such Registered Holder. Registered Bonds shall be transferable only upon delivery of such Bonds to the Registrar, duly endorsed or accompanied by a written instrument of transfer in form satisfactory to the Registrar, executed by the Registered Holder thereof or his attorney duly authorized in writing, and such transfer registered on the Registration Record. If the Form of Assignment on such Bonds is exhausted, such Registered Bonds delivered to the Registrar for registration of transfer shall be canceled by the Registrar on the face thereof and the Registrar shall authenticate and deliver to the transferee Bonds in aggregate principal amount equal to the unpaid principal of the surrendered Bonds in new registered Bonds, in denominations of \$1,000.00 or any multiples thereof. The Registrar shall not be required to make such transfer after the fifteenth (15th) day preceding any interest payment date until after said latter date.

SECTION 6. There is hereby created and established a system of registration for uncertificated registered public obligations with respect to the Bonds as provided in the Registered Public Obligations Act of Oklahoma, Title 62, Oklahoma Statutes 2011, Section 582(13)(b), whereby books shall be maintained on behalf of the City by The Depository Trust Company, New York, New York, for the purpose of registration of transfer of the uncertificated registered public obligations with respect to the Bonds which specify the persons entitled to the uncertificated registered public obligations with respect to the Bonds and the rights evidenced thereby and which provide that the transfer of the uncertificated registered public obligations with respect to the Bonds and the rights evidenced thereby shall be registered upon such books, and the Mayor and City Clerk are hereby authorized and directed to execute such documents and instruments as may be required to implement the foregoing system of registration.

SECTION 7. That beginning with the year 2019, a continuing annual tax sufficient to pay the interest on said Bonds when due and for the purpose of providing a sinking fund with which to pay the principal of said Bonds when due shall be and is hereby ordered levied upon all taxable property in said City, in addition to all other taxes, said sinking fund to be designated "**GENERAL OBLIGATION BONDS, SERIES 2019A, SINKING FUND.**" Said Tax shall be and is hereby ordered certified, levied and extended upon the rolls and collected by the same officers, in the same manner and at the same time as the taxes for general purposes in each of said years are certified, levied, extended and collected; that all funds derived from said tax shall be placed in said sinking fund which, together with any interest collected on same, shall be irrevocably pledged to the payment of the interest on and principal of said Bonds when and as the same fall due.

SECTION 8. The City covenants and agrees that it shall at all times perform all acts and things necessary or appropriate under any valid provision of law to ensure that interest paid on the Bonds shall not be included in gross income of the owners thereof for Federal income tax purposes under the Internal Revenue Code of 1986, as amended.

SECTION 9. That by reason of the City of Midwest City being without adequate streets, parks and recreational facilities, and public safety facilities and equipment, it is deemed and hereby declared necessary for the preservation of the public health, peace and safety that this Ordinance shall become operative immediately; wherefore, an emergency is hereby declared to exist, and this Ordinance shall be in full force and effect immediately from and after its passage and approval.

ADOPTED AND APPROVED this 14th day of May, 2019.

ADOPTED AND APPROVED as an emergency measure this 14th day of May, 2019.

Mayor

ATTEST:

SARA HANCOCK, City Clerk

(SEAL)

APPROVED as to form and legality this 14th day of May, 2019.

HEATHER POOLE, City Attorney

I, the undersigned, the duly qualified and acting City Clerk of the City of Midwest City, Oklahoma hereby certify that the foregoing is a true and complete copy of an Ordinance authorizing the issuance of general obligation bonds for the purpose therein set out adopted by the governing body of said City and Transcript of Proceedings of said governing body at a regular meeting thereof held on the date therein set out, insofar as the same relates to the introduction, reading and adoption thereof as the same appears of record in my office.

I hereby certify that a true and complete copy of the Public Notice, attached hereto as Exhibit "A", was posted in prominent public view at the city Hall, 100 North Midwest Boulevard, Midwest City, Oklahoma, twenty-four (24) hours prior to the date of the meeting therein described, excluding Saturdays, Sundays and legal holidays. I further certify that a true, correct and complete copy of the schedule of regularly scheduled meetings of the City Council of the City for calendar year 2019 was filed in the office of the City Clerk of Midwest City, Oklahoma, as proscribed by law and in accordance with the Oklahoma Open Meeting Act.

WITNESS my hand and seal this 14th day of May, 2019.

City Clerk

(SEAL)



City Manager
100 N. Midwest Boulevard
Midwest City, OK 73110
ghenson@midwestcityok.org
Office: 405.739.1204/Fax: 405.739.1208
www.midwestcityok.org

Memorandum

TO: Honorable Mayor and Council

FROM: Guy Henson, City Manager

DATE: May 14, 2019

SUBJECT: Consider and award of the sale of General Obligation Bonds of the City of Midwest City, Oklahoma in the amount of Seventeen Million Two Hundred Fifty Thousand and no/100s dollars (\$17,250,000.00) to the lowest bidder.

In accordance with Title 62, Oklahoma Statutes, 2011, Section 354, as amended, notice was given that the City of Midwest City, Oklahoma (the "Issuer") will receive sealed written bids and electronic bids on Tuesday, May 14, 2019 at 10:30 a.m. local time, in the Office of the City Clerk, City Hall, 100 North Midwest Boulevard, Midwest City, Oklahoma for the sale of all, but not less than all of \$17,250,000.00 aggregate principal amount of its General Obligation Bonds, Series 2019A (the "Series 2019 Bonds") which Series 2019A Bonds will mature at \$575,000.00 in two years from their date and at \$725,000.00 annually each year thereafter until paid.

Action is necessary to sell the bonds.

These documents will be completed after the opening of the bids for the sale of the bonds on May 14, 2019. Completed original documents will be provided to Council at the meeting.

Sincerely,

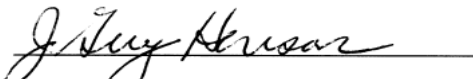

J. Guy Henson, AICP

**THE CITY COUNCIL OF THE CITY OF MIDWEST CITY, STATE OF OKLAHOMA,
MET IN REGULAR SESSION IN THE COUNCIL CHAMBERS AT THE CITY HALL, 100
NORTH MIDWEST BOULEVARD, IN SAID CITY ON THE 14TH DAY OF MAY, 2019, AT
6:00 O'CLOCK P.M.**

PRESENT:

ABSENT:

Notice of the regular meetings of the City Council for calendar year 2019 having been given in writing to the City Clerk of Midwest City, Oklahoma prior to December 15, 2018, and public notice having been posted in prominent public view at the City Hall, 100 North Midwest Boulevard, Midwest City, Oklahoma, twenty-four (24) hours prior to this meeting, excluding Saturdays, Sundays and legal holidays, all in compliance with the Oklahoma Open Meeting Act.

(OTHER PROCEEDINGS)

It appearing that due and legal notice had been given that the City of Midwest City, Oklahoma, would offer for sale on this date and at this hour and at this place its \$17,250,000.00 of General Obligation Bonds, Series 2019A, maturing \$ 575,000.00 in two years from their date and \$725,000.00 annually each year thereafter until paid, the governing body of the City proceeded to consider the bids received for the purchase of said Bonds. The following bids were received and considered by the governing body of the City:

<u>BIDDERS</u>	<u>TRUE INTEREST RATE BID</u>	<u>PREMIUM</u>
----------------	-----------------------------------	----------------

The governing body of the City required each bidder to submit with his bid a sum in cash or its equivalent equal to two percent of his bid, and after due consideration of all bids received by the governing body, a motion was made by _____ that the bonds were awarded, sold, and delivered to _____, upon fulfillment of the terms set out in said contract and bid for the purchase of said Bonds. Said motion was seconded by _____, and was adopted by the following vote:

AYE:

NAY: None

ADOPTED AND APPROVED this 14th day of May, 2019.

Mayor

ATTEST:

SARA HANCOCK, City Clerk

(SEAL)

APPROVED as to form and legality this 14th day of May, 2019.

HEATHER POOLE, City Attorney

I, the undersigned, the duly qualified and acting Clerk of the City of Midwest City, Oklahoma hereby certify that the foregoing is a true and complete copy of the proceedings of the governing body of said City at the time bids were reviewed and considered for the sale of its general obligation bonds, taken at a regular meeting thereof duly held on the date therein set out, as the same appears of record in my office.

I hereby certify that a true and complete copy of the Public Notice, attached hereto as Exhibit "A", was posted in prominent public view at the city Hall, 100 North Midwest Boulevard, Midwest City, Oklahoma, twenty-four (24) hours prior to the date of the meeting therein described, excluding Saturdays, Sundays and legal holidays. I further certify that a true, correct and complete copy of the schedule of regularly scheduled meetings of the City Council of the City for calendar year 2019 was filed in the office of the City Clerk of Midwest City, Oklahoma, as proscribed by law and in accordance with the Oklahoma Open Meeting Act.

WITNESS my hand and seal this 14th day of May, 2019.

(SEAL)

City Clerk



Emergency Management

100 N. Midwest Boulevard

Midwest City, OK 73110

office 405.739.1386

To: Honorable Mayor and City Council

From: Mike Bower, Midwest City Emergency Manager

Date: May 14, 2019

Subject: Discussion and consideration of 1) approving a change order in the amount \$22,770.00 with SafetyCom, Inc. for additional equipment to encrypt the outdoor warning sirens, and 2) purchasing the necessary encrypted radio equipment from Total Radio in the amount of \$29,973.24 per the Oklahoma State Contract #SW1053M, Public Safety Communication Equipment-Motorola Solutions. (Emergency Management - M. Bower).

As you may recall, the Council awarded the purchase and installation of the outdoor warning sirens and related equipment that were previously bid separately. Since that time, a secure method of communicating and alerting the equipment has become available. Staff recommends upgrading the alerting equipment purchased originally from SafetyCom, Inc. for the necessary encrypted equipment from the same vendor at an additional cost of \$22,770.00.

In addition, each of the ten sirens, as well as dispatch, will require a new encrypted radio to be purchased from Total Radio in the amount of \$29,973.24 which will allow for the secure alerting of the sirens.

A handwritten signature in black ink that reads "Mike Bower". The signature is written in a cursive style and is positioned above a horizontal line.

Mike Bower
Emergency Manager



Emergency Management
100 N. Midwest Boulevard
Midwest City, OK 73110
office 405.739.1386

Project Change Request

Change Request Number :
Date: 05/14/2019

Party requesting change: [X] City of Midwest City [] Safety Com

Reason for the proposed change:

SafetyCom has provided Midwest City an estimate to provide upgraded radio equipment not requested in the original Invitation to Bid. The estimate provides equipment for the City to upgrade the specified radio modules in each siren to a P25 compatible encrypted radio package that would seriously inhibit the possibility of the siren system from being falsely activated by an unauthorized signal sent over the siren radio frequencies.

Live weekly testing of the siren system is necessary for the health of the siren system, but exposes the radio signal to potential hackers that in recent years have begun activating communities sirens and causing massive disruptions to their 911 centers.

Requirements for change:

Staff recommends the purchase of the additional equipment to encrypt the outdoor warning system necessary to insure security of the signal between the dispatch center and the outdoor warning sirens to prevent malicious use of siren systems.

Impact of the proposed change on project:

The initial installation will utilize the original radio equipment as specified in the Invitation to Bid which is the same radio system the existing sirens are operating on currently. The additional encrypted radio equipment will be phased in as replacements once testing and optimization of the radio signals is achieved and verified before completely converting to the new radios.

Pricing:

The increased cost for the additional equipment to encrypt the outdoor warning sirens is \$22,770.00.

This Project Change Request is (circle): Approved Rejected

City of Midwest City

By: _____
Signature
Name: _____
Printed Name
Title: _____
Date: _____
Attest: _____

SafetyCom, Inc.
By: _____
Signature
Name: David B. Miller
Printed Name
Title: President
Date: Apr 18, 2019
Attest: _____



112 Smarthouse Way
 North Little Rock, AR 72114
 Phone: (888) 375-6355
 Fax: (501) 372-2221

Quotation

DATE	ESTIMATE NO.
3/18/2019	MWC032119...

NAME / ADDRESS
Midwest City, OK. P.O. Box 10570 Midwest City, OK. 73140-1570

PROJECT NAME		
P25 Interface Board Upgrade		

DESCRIPTION	QTY	COST	TOTAL
BYTEL P25 Package (BWEN/P25 Trunked/Whelen Housing Mounted Door Knob Antenna - Customer provided APX4000 radio)	11	2,070.00	22,770.00T
Sales Tax		0.00%	0.00

Installation & Tax not Included	TOTAL	\$22,770.00
---------------------------------	--------------	-------------



Account Manager:
 1507 Lyndon B. Johnson Freeway Suite 700
 Dallas, TX 75234

Date: 3 1 19
 Quote#: MWC3119
 Contract Number: NASPO SW1053M



Prepared For: Scott Walch Phone Number: Email: Agency: City of Midwest City	Ship to Address:	Ship to Address:
--	------------------	------------------

Qty	Description	Nomenclature	List Price	Contract Price	Extended
11	APX 4000 PORTABLE RADIO 7/800 MHZ	H51UCF9PW6	\$1,963.00	\$1,432.99	\$15,762.89
11	3600/9600 BAUD TRUNKING	QA02756	\$1,570.00	\$1,146.10	\$12,607.10
11	AES ENCRYPTION	Q629	\$475.00	\$346.75	\$3,814.25
1	KVL3000 Cable for APX	WPLN6904	\$110.00	\$99.00	\$99.00
11	3 YEAR WARRANTY	H885	\$90.00	\$90.00	\$990.00
11	P-25 PROMOTION		-\$300.00	-\$300.00	-\$3,300.00
				TOTAL	\$29,973.24

NOTES:

- 1 NASPO CONTRACT #SW1053M
- 2 PURCHASE ORDER TO BE MADE TO MOTOROLA SOLUTIONS, INC.
- 3 PAYMENT TERMS NET 30 DAYS. PURCHASE ORDER MUST REFLECT PAYMENT TERMS.
- 4 P.O. NEEDS TO STATE BILL TO & SHIP TO ADDRESSES

\$0.00

Invitation for Sealed Bids

*****AMENDMENT #1***
CITY OF MIDWEST CITY**

100 N. MIDWEST BLVD., MIDWEST CITY, OKLAHOMA 73110

Write legibly in ink or use typewriter. Please see agreement on next page.

Published in:
Midwest City Beacon

Date Advertised:
December 28, 2018-DECEMBER 21, 2018

Bids must be in the Office of the City Clerk by: **Tuesday, January 8th, 2019, no later than 2:00p.m.**

IMPORTANT: Bid envelope must indicate bid item enclosed and date of bid opening.

Description	Quantity	Unit Price	Volume Pricing
Purchase of Ten (10) Whelen Outdoor Warning Siren Hardware:			
Whelen 2910: 10-bay siren	Ten (10)	\$24,800	\$248,000
Whelen C2030NV: Two-way VHF radio controlled	Ten (10)	\$1,445	\$14,450
Whelen INTRUWPS: Intrusion Detection	Ten (10)	\$170	\$1,700
Whelen SBC280: Solar Power Option	Ten (10)	\$2,100	\$21,000
60' spun concrete pole: Mounting points and covered cable chase for installation of above Whelen 2910 hardware	Ten (10)	\$4,510	\$45,100

THE CITY OF MIDWEST CITY IS EXEMPT FROM PAYMENT OF OKLAHOMA SALES TAX AND FEDERAL EXCISE TAX.

I have examined the specifications and agree, provided I am awarded a contract within thirty (30) days from the date fixed for opening bids, to provide the above described items for the sum shown, in accordance with the terms set out in the attached "Agreement by Bidder."

DELIVERY WILL BE MADE IN 60 DAYS OR LESS FROM DATE OF ORDER. DATED THIS 8th DAY OF January, 2019

FIRM SafetyCom, Inc. BY David B. Miller
ADDRESS 112 Smarthouse Way TITLE President

Accepted by the City Council this 22 day of January, 2019.
Sara Hancock City Clerk
[Signature] Mayor

Approved as to form this 23 day of January, 2019.
[Signature] City Attorney



City of Midwest City Police Department

100 N. Midwest Boulevard

Midwest City, OK 73110

Office 405.739.1320

Fax 405.739.1398

Memorandum

TO: Honorable Mayor and City Council

FROM: Brandon Clabes, Chief of Police

DATE: May 14, 2019

SUBJECT: Discussion and consideration of approving and awarding proposal to Tyler Technologies for their Brazos' eCitation and eCrash Solutions, who submitted the only bid, in the amount of \$23,557.00 (five year total includes \$564 annual maintenance) for one device, and \$6,500.00 for software modules with a \$1,300 annual maintenance.

On Tuesday, March 5, 2019 at 2:00 p.m., the City of Midwest City opened one proposal for Electronic Citation and Crash Management Information Solution. Proposal notice was published in the Midwest City Beacon on February 15, 2019.

Staff recommends approval.

Brandon Clabes
Chief of Police

Bid Tabulation

Electronic Citation and Crash Management Information Solution

Opened: March 5, 2019

Awards: May 14, 2019

ONLY 1 BID RECEIVED

Tyler Technologies

\$23,557.00 (5yr total based on qty of 1)

Invitation for Sealed Proposals

REQUEST FOR PROPOSAL (RFP)

Electronic Citation and Crash Management Information Solution

CITY OF MIDWEST CITY
100 N. MIDWEST BLVD., MIDWEST CITY, OKLAHOMA 73110

Write legibly in ink or use typewriter.

Published in:
Midwest City Beacon

Date Advertised:
February 15, 2019

Proposals must be in the Office of the City Clerk By: Tuesday, March 5, 2019 no later than 2:00 PM CST.

IMPORTANT: Proposal envelope must indicate proposal item enclosed and date of proposal opening.

Table with 2 columns: Description, Price. Row 1: Electronic Citation and Crash Management Information Solution, \$ 23,557 (5 year total based on qty of 1)

THE CITY OF MIDWEST CITY IS EXEMPT FROM PAYMENT OF OKLAHOMA SALES TAX AND FEDERAL EXCISE TAX.

I have examined the specifications and agree, provided I am awarded a contract within thirty (30) days from the date fixed for opening bids, to provide the above described items for the sum shown, in accordance with the terms set out in the attached "Agreement by Bidder."

DELIVERY WILL BE MADE IN 210 DAYS OR LESS FROM DATE OF ORDER. DATED THIS 5th DAY OF March, 2019

FIRM Tyler Technologies BY Mike McAleer

ADDRESS 526 University Dr. East, Suite 201A TITLE General Manager - Brazos College Station, TX 77840

Accepted by the City Council this day of , 2019.

City Clerk signature line

Approved as to form this day of , 2019.

Mayor signature line

City Attorney signature line



Quoted By: Kimberly Germer
 Quote Expiration: 6/30/2019
 Quote Name: City of Midwest City, OK-RFP-BZ
 Quote Number: 2019-68347
 Quote Description:

Sales Quotation For

City of Midwest City
 100 N Midwest Blvd
 Midwest City , OK 73110-4327
 Phone: +1 (405) 869-8600

Tyler Software

Description	Quantity	License	Software Total	Year One Maintenance
Brazos				
Interface: Incode Public Safety Records Mgmt System	1	\$0	\$0	\$0
Interface: Tyler Incode Court Case Mgmt System	1	\$0	\$0	\$0
eCitation - Brazos Rapid Extension Framework - PDA	1	\$850	\$850	\$179
TOTAL:			\$850	\$179

Tyler Software and Related Services - Annual

Description	Quantity	Unit Price	Annual Fee
Brazos			
Brazos Hosting Fee	1	\$60	\$60
State Compliant Crash Report Software with Drawing Tool	1	\$325	\$325
TOTAL:			\$385

Professional Services

Description	Quantity	Unit Price	Extended Price
Set Up & Config	1	\$10,000	\$10,000
Standard CrashTraining Package	1	\$1,500	\$1,500
State Compliant Crash Report Config & Set Up	1	\$2,500	\$2,500
Training	1	\$2,000	\$2,000
Set Up Fees - Third Party Hardware	1	\$50	\$50
Brazos Project Mgmt (plus per diem as needed if not remote)	1	\$1,000	\$1,000
TOTAL:			\$17,050



Third Party Hardware, Software and Services

Description	Quantity	Unit Price	Unit Discount	Total Price	Maintenance
FZ-VCBN121M / Panasonic, N1, 4 Bay Battery Charger	1	\$426	\$0	\$426	\$0
FZ-VEBN121M / Panasonic, N1, 4 Bay Cradle	1	\$723	\$0	\$723	\$0
FZ-VZSUN120U / Panasonic, N1, Battery, Long Life	1	\$121	\$0	\$121	\$0
FZ-VSTN11U / Panasonic, N1, Hand Strap	1	\$35	\$0	\$35	\$0
CF-AA6373AM / Panasonic, X1, AC Adapter	1	\$48	\$0	\$48	\$0
FZ-SVCHHUC3Y / Panasonic, Warranty, Ultimate Care, 3 year	1	\$233	\$0	\$233	\$0
FZ-N1EBJZZDM / Panasonic, HH, N1, 8.1 w/data and voice, long life battery	1	\$1,490	\$0	\$1,490	\$0
TOTAL:				\$3,076	

Summary	One Time Fees	Recurring Fees
Total Tyler Software	\$850	\$179
Total Tyler Annual	\$0	\$0
Total Tyler Services	\$17,050	\$0
Total Third Party Hardware, Software and Services	\$3,076	\$0
Summary Total	\$20,976	\$564

Contract Total (based on quantity above)	
Year 1	\$21,301 (includes \$325 for first year of eCrash)
Year 2	\$564
Year 3	\$564
Year 4	\$564
Year 5	\$564
Contract Total for 5 years	\$23,557



Optional Tyler Software

Description	Quantity	License	Software Total	Year One Maintenance
Brazos				
Task: Driver Exchange Module	1	\$3,250	\$3,250	\$683
Task: Tow/Impound Report (standard)	1	\$3,250	\$3,250	\$683
	<i>Sub Total:</i>	\$6,500	\$6,500	\$1,366
	TOTAL:	\$6,500	\$6,500	\$1,366

Unless otherwise indicated in the contract or Amendment thereto, pricing for optional items will be held for Six (6) months from the Quote date or the Effective Date of the Contract, whichever is later.

Customer Approval: _____ Date: _____

Print Name: _____ P.O.#: _____





Information Technology
100 N. Midwest Boulevard
Midwest City, OK 73110
Office 405.739.1374
Fax 405.869.8602

MEMORANDUM

TO: Honorable Mayor and City Council

FROM: Ryan Rushing, Information Technology Director

DATE: May 14, 2019

SUBJECT: Discussion and consideration of the 1) purchase and installation of Kenwood/EF Johnson P25 radios for the Fire department in the amount of \$283,588.34 from the Oklahoma County contract # CW19044 with Stolz Telecom LLC and 2) approving the resolution authorizing the purchase and installation of Kenwood/EF Johnson P25 radios under the Oklahoma County contract #CW19044 with Stolz Telecom LLC.

As you may recall, one of the items on the Moving Midwest City Forward 2018 Public Safety Bond projects list was the purchase and installation of new P25 Public Safety mobile and portable radios. The Fire Department's radios are failing and at a critical state at this time. Staff has worked with the Fire Department and has verified the need for the purchase of fifty-five (55) fully featured FIRE YELLOW Viking Intrinsically Safe portables with station chargers, extra batteries, speaker mics, boston leather holsters with different size boston belts and bridle straps as well as 28 new mobiles in Fire Apparatus and 12 new mobile "consolette" style radios for the Fire Stations and Dispatch consoles. IT staff will program all of the radios and install the Dispatch consolettes and coordinate with Stolz Telecom, LLC for the installation of the mobiles in the Fire Department's apparatus. This solution fits into our overall communications plan and is fully compatible with the recently acquired Public Safety 7-channel single-site P25 700 MHz trunking radio system.

Under the provisions of Section 2-118 of the Midwest City Code, which states, "Every contract for purchase of supplies, materials or equipment exceeding twenty-five thousand dollars (\$25,000.00) shall be purchased from the lowest and best bidder after due notice inviting bids by this city **or any other political subdivision in the state with similar or more stringent bidding requirements . . .**," the best pricing found was by using the Oklahoma County contract which was bid on December 11, 2018 for a contract coverage period of January 31, 2019 through January 31, 2020 for a twenty-two (22) percent discount off list price. The cost of the Kenwood/EF Johnson P25 radios using the vendor on the Oklahoma County contract # CW19044 will be in the amount of \$283,588.34 which was approved in the Moving Midwest City Forward 2018 bond.

Staff recommends approval.

Ryan Rushing, Information Technology Director

RESOLUTION NO. 2019-_____

A RESOLUTION AUTHORIZING THE PURCHASE AND INSTALLATION OF THE KENWOOD/EF JOHNSON P25 RADIOS UNDER OKLAHOMA COUNTY'S 2019-2020 CONTRACT WITH STOLZ TELECOM, LLC.

WHEREAS, it is necessary that the City of Midwest City purchase the Kenwood/EF Johnson P25 radios including accessories, equipment, software, and installation; and

WHEREAS, Oklahoma County, after providing ample opportunity for competitive bidding as required by Oklahoma County's Purchasing and Bid Regulations and the City of Midwest City's Charter, awarded a contract for Kenwood/EF Johnson P25 radios to Stolz Telecom, LLC. for fiscal year 2019-2020; and

WHEREAS, Stolz Telecom, LLC. is a reputable and stable company that can provide reliable equipment needed by the City of Midwest City; and

WHEREAS, Stolz Telecom, LLC. has indicated a willingness to charge the City of Midwest City the same or a lower price for the Kenwood/EF Johnson P25 radios it purchases and their installment as is charged to Oklahoma County for similar equipment;

NOW, THEREFORE, BE IT RESOLVED by the City Council of the City of Midwest City:

1. That it accepts and adopts Oklahoma County's bid for the Kenwood/EF Johnson P25 radios under the same terms and conditions;
2. That the City of Midwest City hereby awards the bid for the Kenwood/EF Johnson P25 radios for fiscal year 2019-2020 to Stolz Telecom, LLC.; and
3. That, it being immediately necessary for the preservation of the peace, health and safety of the City of Midwest City and its inhabitants, this resolution shall take effect and be in full force from and after its passage as provided by law.

PASSED and APPROVED by the City of Midwest City this 14th day of May, 2019.

CITY OF MIDWEST CITY

Matthew D. Dukes, II, Mayor

ATTEST:

Sara Hancock, City Clerk

APPROVED as to form and legality this 14th day of May, 2019.

HEATHER POOLE, City Attorney

Radios, Base Stations, and Equipment

Award Number: 4-19

Date: February 4th, 2019

Bid Number: CW19044

Bid Period: February 4th, 2019 through January 31st, 2020

Awarded Vendor(s):

Lawton Communications
6210 NW Oak Avenue
Lawton, OK 73505
Contact: Jeff Reinke
Phone: 580-536-2242
Fax: 580-536-1073
Email: jreinke@lawton-comm.com

Stolz Telecom, LLC
6825 Camille Avenue
Oklahoma City, OK 73149
Contact: John D. Mayes
Phone: 405-632-2262
Fax: 877-457-2262
Email: john.mayes@stolztele.com

Chickasaw Personal Communications, Inc.
717 S. Dewey Avenue
Oklahoma City, OK 73109
Contact: Butch McCurdy
Phone: 580-223-5162
Email: bmccurdy@chickasawpersonal.com

Primus Electronics
4180 E. Sand Ridge Road
Morris, IL 60450
Contact: Sue Hendrick
Phone: 800-435-1636
Fax: 800-767-7605
Email: sue@primuselectronics.com

Holzberg Communications, Inc.
PO Box 322
Totowa, NJ, 07511
Contact: Andy Holzberg
Phone: 800.654.9550
Email: Holzberg@juno.com

EMR Corporation
17431 N 25th Ave.
Phoenix, AZ 85023
Contact: Bruce J. Wallace
Phone: 623-581-2875
Email: sales@emrcorp.com

BK Technologies, Inc.
7100 Technology Drive
West Melbourne, FL 32904
Contact: Kelly Roberts
Phone: 321-237-1306
Email: lroberts@bktechnologies.com

**OKLAHOMA COUNTY, OKLAHOMA
OKLAHOMA COUNTY PURCHASING AGENT**

This is not a Purchase Order. This is only a notice to the successful bidder. No order may be placed without a Purchase Order being issued by Oklahoma County.

**Board of County Commissioners
Of Oklahoma County, Oklahoma**

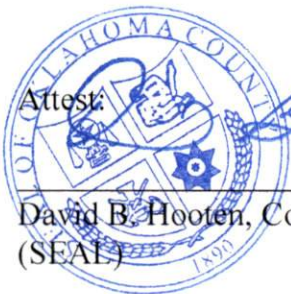

Attest:

David B. Hooten, County Clerk
(SEAL)

Chairman

Member

Member

CW19044 RADIOS, BASE STATIONS, AND EQUIPMENT TABULATION Contract Period: February 4th, 2019 through January 31, 2020

	PRIMUS ELECTRONICS CORP. 4180 E. SAND RIDGE RD. MORRIS, IL 60450 CONTACT: SUE HENDRICK PHONE: (800) 435-1636 EMAIL: SUE@PRIMUSELECTRONICS.COM	EMR CORPORATION 17431 N 25TH AVE. PHONEX, AZ 85023 CONTACT NAME: BRUCE J. WALLACE PHONE NUMBER: 623-581-2875 EMAIL: SALES@EMRCORP.COM	LAWTON COMMUNICATIONS 6210 NW OAK AVE. LAWTON, OK 73505 CONTACT: JEFF REINKE PHONE: 580-536-2242 EMAIL: JREINKE@LAWTON-COMM.COM	HOLZBERG COMMUNICATIONS, INC. POBOX 322 TOTOWA, NJ 07511 CONTACT: ANDY HOLZBERG PHONE: 800-654-9550 EMAIL: HOLZBERG@JUNO.COM	STOLZ TELECOM, LLC 6825 CAMILLE AVE. OKLAHOMA CITY, OK 73149 CONTACT: JOHN D. MAYES PHONE: 405-632-2262 EMAIL: JOHN.MAYES@STOLZTELE.COM	BK TECHNOLOGIES, INC. 7100 TECHNOLOGY DRIVE WEST MELBOURNE, FL 32904 CONTACT: KELLY ROBERTS PHONE: 321-237-1306 EMAIL: LROBERTS@BKTECHNOLOGIES	CHICKASAW PERSONAL COMM. 717 S. DEWEY AVE. OKLAHOMA CITY, OK 73109 CONTACT: BUTCH MCCURDY PHONE: 580-223-5162 EMAIL: BMCCURDY@CHICKASAWPERSONAL.COM
SECTION I: Radios							
1.) Harris Communications					30%		
2.) Motorola (Excluding Trunked Radio)			33%				
3.) Kenwood USA (Excluding NexEdge)							34.50%
4.) EF Johnson					22%		
5.) Thales, Inc.							
6.) Tait Corporation					26%		
7.) Icom				21%			
8.) Daniels Electronics					20%		
9.) Datron, Inc.							
10.) JPS/Raytheon Corporation							10%
11.) Vertex			33% (NOW MOTOROLA PER VENDOR)				
12.) Simco							
13.) Pyramid Communications Vehicular					21%		
14.) R.F. Technologies				3%			
15.) RELM Wireless Wireless Corporation						34%	
SECTION II: Base Station Radio Equipment							
1.) Harris Communications					27%		
2.) Motorola (Excluding Trunked Radio)							22%
3.) Kenwood USA (Excluding NexEdge)							34.50%
4.) EF Johnson							21.50%
5.) Thales, Inc.							
6.) Tait Corporation					26%		
7.) Icom				21%			
8.) Codan					20%		
9.) Datron, Inc.							
10.) JPS/Raytheon Corporation							10%
11.) Vertex			25% (NOW MOTOROLA PER VENDOR)				
12.) Simco							

13.) R.F. Technologies				3%			
14.) RELM Wireless Wireless Corporation							
SECTION III: Mobile Radio Accessories							
1.) Harris Communications					27%		
2.) Motorola (Excluding Trunked Radio)				26%			
3.) Kenwood USA (Excluding NexEdge)							34.50%
4.) EF Johnson					22%		
5.) Thales, Inc.							
6.) Tait Corporation					26%		
7.) Icom				21%			
8.) Daniels Electronics					20%		
9.) Datron, Inc.							
10.) JPS/Raytheon Corporation							10%
11.) OTTO Corporation				30%			
12.) Stone Mountain Corporation							25%
13.) Vertex							20%
14.) Simoco							
15.) R.F. Technologies				3%			
16.) SetCom				3%			
17.) Sigtronics				6%			
18.) Power Products				21%			
19.) RELM Wireless Wireless Corporation						34%	
SECTION IV: Mobile Radio Antennas/Mounts							
1.) Comtelco Corporation	52%						
2.) Radial Larsen	55%						
3.) Laird Technologies	55%						
4.) PCTEL/Maxrad	55% OFF MOST PRODUCTS						
5.) R. F. Technologies							
6.) RELM Wireless Wireless Corporation						34%	
SECTION V: Base Station Antennas/ Mounts/ Hardware							
1.) Decibel Products	28%						
2.) RFS Antennas	*						
3.) Comscope, Inc.	HELIX PRODUCT :26% CABLE,28%CONNECTORS , 18% HARDWARE					20%	
4.) Sinclair Corporation	25%						
5.) RFI/Bird Technologies	11% OFF MOST PRODUCT			12%	11%		
6.) Mobile Mark, Inc.				31%			
7.) Radio Waves, Inc.	25%						
8.) EMR Corporation	28%						

9.) Terrawave Corporation							
10.) R.F. Technologies							
NOTES:	**RFS DOES NOT HAVE LIST PRICES. PRIMUS CAN OFFER QUOTES WHEN PRODUCT IS NEEDED. (SECTION 6.2)						
SECTION VI: Duplexers/ Combiners/ Cavities/ Filters/ Preamp/ Splitters							
1.) Decibel Products	28%						
2.) Telewave Corporation	25%						
3.) TX-RX Corporation	23%						
4.) Sinclair Corporation	25%						
5.) RFI/Bird Technologies	11% OFF MOST PRODUCT			12%	10%		
6.) EMR Corporation		35%					
7.) Microlab/ GXR	10%						
8.) R. F. Technologies							
9.) RELM Wireless Wireless Corporation						34%	
SECTION VII: Tone Remotes/ Audio Bridges/ Radio Inter-Operability							
1.) JPS Raytheon Corporation				6%			
2.) CPI Communications	23%						
3.) Collcomm Inc							
4.) Link Communications					5%		
5.) R.F. Technologies				3%			
6.) SLA Corp: Enterprise Secure Chat (ES Chat)					5%		
7.) Raven Electronics Corporation					5%		
8.) TC Communications				3%			
SECTION VIII: Power Supplies/ Batter Chargers/ Cabinets/ Hardware							
1.) AdvanceTec, Inc.				3%			
2.) Astron Corporation	23%						
3.) Duracom, Inc.	20% OFF MOST PRODUCT						
4.) BUD, Inc.							
5.) R.F. Technologies				3%			
6.) RELM Wireless Wireless Corporation						34%	
NOTES:							
SECTION IX: Test/ Measuring/ Calibration Equipment							
1.) General Dynamics, Inc.							
2.) Bird Technologies							

3.) AEA Corporation							
4.) Aeroflex							
5.) R.F. Technologies				3%			
SECTION X: Control Over Ethernet Equipment							
1.) Perle Systems				1%			
2.) Moxa Industrial							
3.) Acromag Busworks							
4.) R.F. Technologies				3%			
5.) TC Communication				3%			
SECTION XI: Contract Radio Repair Services: Hourly/Flat Rate Fee \$							
1.) Harris Communications				\$150.00			
2.) Motorola (Excluding Trunked Radio)				\$84.00			
3.) Kenwood USA (Excluding NexEdge)				\$84.00			
4.) EF Johnson				\$84.00			
5.) Thales, Inc.							
6.) Tait Corporation				\$150.00			
7.) Icom				\$84.00			
8.) Daniels Electronics				\$150.00			
9.) Datron, Inc.				\$150.00			
10.) JPS/Raytheon Corporation				\$84.00			
11.) Vertex				\$84.00			
12.) Simco				\$150.00			
13.) Pyramid Communications Vehicular				\$150.00			
14.) R.F. Technologies				\$150.00			
15.) RELM Wireless Wireless Corporation						34%	
Reprogramming Fee Per Radio (If applicable) \$:			\$10.00				
Delivery Time After Receipt of Order:	1-4 WEEKS ARO (SOME PRODUCT MAY BE LONGER)		1-2 WEEKS OR LESS	15 DAYS	2-4 WEEKS ARO	15 DAYS	15 DAYS
Warranty: (If other than manufacturer warranty):	MANUFACTURER'S WARRANTY APPLIES						
Shipping and Handling Costs:	N/A FOR STANDARD SHIPPING		INCLUDED	NONE	NONE	PRE-PAID, FOB DESTINATION	NONE



Stolz Telecom LLC
 6825 Camille Avenue
 Oklahoma City, OK 73149
 (405) 632-2262
 John.Mayes@StolzTelecom.com
 http://www.stolztele.com

ESTIMATE

ADDRESS

Allen Stephenson
 Midwest City Information
 Technology Department
 100 N Midwest Blvd
 Midwest City, OK 73110

SHIP TO

Allen Stephenson
 Midwest City Information
 Technology Department
 100 N Midwest Blvd
 Midwest City, OK 73110

ESTIMATE # 5028

DATE 04/23/2019

EXPIRATION DATE 06/28/2019

SHIP VIA

PICK UP

CONTRACT

CW19044

ITEM	QTY	PRICE	TOTAL
FIRE DEPARTMENT 700/800 MHZ EF JOHNSON/KENWOOD PORTABLE RADIO QUOTE			
Sales	55	2,569.32	141,312.60
EF JOHNSON/KENWOOD VIKING SERIES VP6000 - 700/800 MHz Model 2 PORTABLE RADIO with FIRE YELLOW HOUSING, Model Options: Immersion Model Options: Micro SD memory card (installed) INTRINSICALLY SAFE (CSA) Antenna: KRA-32K 7/800 MHz 1/2 Wave (Whip) Battery: KNB-LS5 Li-ion 2000 mAh INTRINSICALLY SAFE Protocol: Analog FM Protocol: P25 CAI AMBE+2 System: Analog Conventional System: 8322000002 P25 Conventional - \$350 System: 8322000005 P25 Phase 1 Trunking - \$125 System: 8322000006 P25 Phase 2 TDMA System: 8326000002 MDC1200 - \$ 50 Channels: 8326000006 1024 Ch Prog and Data: TrueVoice Noise Cancellation Standard Warranty: 3 Year = \$3,294 LIST			
KNB-LS5	55	156.00	8,580.00
LI-ION Battery, 2000 MAH, Intrinsically Safe			
KMC-54WDM	55	101.40	5,577.00
MIL-SPEC, IP67 (Immersion) Speaker Mic			
KSC-32	10	54.60	546.00
Rapid rate single unit charger			
R50843LP2001	55	54.60	3,003.00

ITEM	QTY	PRICE	TOTAL
BOSTON Leather for VP6000 Series Radio			
Sales R50840000UB0 - LEATHER UTILITY BELT FOR LEATHER BOSTON CASE	55	58.50	3,217.50
Sales R50840000AS0 - Boston leather (English Bridle) leather for ultimate comfort and long life. Designed to increase unit stability, it measures approximately 11, ½ inches long and 1 inch wide.	55	15.60	858.00
EC12M ENDURA TWELVE-UNIT CHARGER INCLUDING SIX DUAL PODS	9	734.40	6,609.60
TWP-KW4A-D DUAL PODS FOR KENWOOD VP6000 BATTERIES	54	0.00	0.00
TOTAL			\$169,703.70

Accepted By

Accepted Date



Stolz Telecom LLC
 6825 Camille Avenue
 Oklahoma City, OK 73149
 (405) 632-2262
 John.Mayes@StolzTelecom.com
 http://www.stolztele.com

ESTIMATE

ADDRESS

Allen Stephenson
 Midwest City Information
 Technology Department
 100 N Midwest Blvd
 Midwest City, OK 73110

SHIP TO

Allen Stephenson
 Midwest City Information
 Technology Department
 100 N Midwest Blvd
 Midwest City, OK 73110

ESTIMATE # 5020

DATE 04/24/2019
 EXPIRATION DATE 05/31/2019

SHIP VIA
 PICK UP

CONTRACT
 CW19044

ITEM	QTY	PRICE	TOTAL
STATE CONTRACT QUOTE -			
KENWOOD VIKING SERIES 700/800 MHZ VM5000 DASH MOUNT MOBILE RADIOS			
Sales KENWOOD - VIKING VM5000 DASH for APPARATUS MOUNT MOBILE RADIO - 700/800 MHZ w/ KCH-19 Control Head, Microphone: KMC-35 Standard Mobile Mic KCT-23M DC Cable - 10 ft, KMB-33M Standard Deck Mounting Bracket, KCT-46 Ignition Sense Cable, KES-5 Speaker KAP-2 HA / PA Relay Analog FM, P25 CAI AMBE+2, Analog Conventional, P25 Conventional, P25 Phase 1 Trunking, P25 Phase 2 TDMA, 1024 Channels, Conventional Voting Scan, TrueVoice Noise Cancellation, Standard Warranty: 3 Year	28	2,313.44	64,776.32
NMO58U-NC 3/4" Brass Mount/ No Conn	28	19.00	532.00
RFN-1005-3C1 N Male Crimp-RG55/RG142	28	7.00	196.00
MAX7603S	28	39.00	1,092.00

ITEM	QTY	PRICE	TOTAL
760-870 3 dB Ant w/Spring			
UTEL Upfit Technician Estimated Labor - INSTALLATION OF EFJ-KENWOOD VIKING DASH MOUNT MOBILE RADIOS INTO 28 APPARATUS W/ SOME INTERFACED INTO SIGTRONICS HEADSETS = \$600.00 PER UNIT	28	600.00	16,800.00
			Subtotal: 83,396.32
KENWOOD VIKING VM5000 700/800MHZ CONSOLLETES IN FIRE STATIONS AND DISPATCH			
EF JOHNSON/KENWOOD VIKING VM5000 700/800 MHZ CONTROL STATION W/ KCH-19 CONTROL HEAD - KMC-35 Standard Palm Microphone KCT-23M DC Cable - 10 ft, KMB-34 Mounting Case, KMB-33M Standard Deck Mounting Bracket, KPS-15 DC Switch (P/S) KAP-2 HA / PA Relay Analog FM, P25 CAI AMBE+2, Analog Conventional, P25 Conventional, P25 Phase 1 Trunking, P25 Phase 2 TDMA, 1024 Channels, Conventional Voting Scan, TrueVoice Noise Cancellation, Standard Warranty: 3 Year	12	2,427.36	29,128.32
DOES NOT INCLUDE A 700/800 MHZ ANTENNA NETWORK FOR EACH CONTROL STATION.			Subtotal: 29,128.32
Sales DEMO FIRE VP5000 MII 700/800 MHz Portable Radio w/ P25 Conventional, P25 Phase I, SmartZone, Audio Recording Test Equipment to set levels and P25 system features	1	1,360.00	1,360.00
			Subtotal: 1,360.00

TOTAL

\$113,884.64

Accepted By

Accepted Date

MEMO

To: Honorable Mayor and City Council

From: Bert Norton, Fire Chief

Date: May 14, 2019

Subject: Discussion and consideration of awarding the bid and entering into a contract with Casco Industries for New Self Contained Breathing Apparatus (SCBA) and associated, bid upon, equipment and optional accessories, in a total amount of \$436,875.

On Tuesday, April 23, 2019, bids were opened for New Self Contained Breathing Apparatus and associated equipment and optional accessories. Only 1 bid was received, which was from Casco Industries.

Staff recommends awarding the bid to Casco Industries with the selected purchase options in the amount of \$436,875, as follows:

Description	Quantity	Unit Price	Total Price
SCBA w/Telemetry	47	\$5,667	\$266,349
Masks	91	\$215	\$19,565
45min Air Cylinders	82	\$924	\$75,768
60min Air Cylinders	10	\$1,022	\$10,220
Mask Adapters	100	\$149	\$14,900
Rapid Intervention Packs	4	\$3,984	\$15,936
SCBA Spare Batteries	36	\$217	\$7,812
110 Volt Battery Charger	6	\$437	\$2,622
Vehicle Mounted Battery Charger	1	\$538	\$538
Tech Training	4	\$895	\$3,580
Air Cart, Tech Rescue	1	\$4,645	\$4,645
4500 PSI Bottle	2	\$969	\$1,938
Premaire Cadet Escape	2	\$1,393	\$2,786
Fill Station Fill Adapter	6	\$288	\$1,728
Spectacle Kit	4	\$102	\$408
25' Air Hose	8	\$247	\$1,976
ID Tag	100	\$33	\$3,300
Tag Reader/Writer	2	\$526	\$1,052
Base Station	1	\$1,752	\$1,752



Midwest City Fire Department

8201 E. Reno Avenue
Midwest City, OK 73110

Office 405.739.1340

Fax 405.739.1384

Funding will be coming from a combination of a federal grant and general obligation bonds in the 041 Fire Department capital outlay account and 270 (2018) GO Bond account.

Bert Norton
Fire Chief

Attachments: Casco Bid Packet

Midwest City Fire Department

We exist to reduce risk, provide emergency assistance, and add value to our community.
www.midwestcityok.org

Invitation for Sealed Bids

CITY OF MIDWEST CITY

100 N. MIDWEST BLVD.
MIDWEST CITY, OKLAHOMA 73110

Write legibly in ink or use typewriter.

Published In
The Journal Record

Dates Advertised
April 10, 2019

Bids must be in the Office of the City Clerk By:
Tuesday, April 23, 2019 no later than 2:00 p.m.

IMPORTANT: Bid envelope must indicate bid item enclosed and date of bid opening.

Description	Quantity	Unit Price	Total Net Price
Self-Contained Breathing Apparatus (SCBA):			
SCBA Harness with Battery	46	5317 ⁰⁰	244,582 ⁰⁰
Masks	107	215 ⁰⁰	23,005 ⁰⁰
45 Minute 5500 psig cylinders	82	924 ⁰⁰	75,768 ⁰⁰
60 Minute 5500 psig cylinders	10	1022 ⁰⁰	10,220 ⁰⁰
P-100 APR adapter with Organic Vapor	107	149 ⁰⁰	15,943 ⁰⁰
RIT Packs	4	3984 ⁰⁰	15,936 ⁰⁰
Spare SCBA Batteries	36	217 ⁰⁰	7,812 ⁰⁰
110 Volt Battery Charger	6	437 ⁰⁰	2,622 ⁰⁰
Vehicle Mounted Battery Charger	1	538 ⁰⁰	538 ⁰⁰
*Industrial SCBA	6	1276 ⁰⁰	7,656 ⁰⁰
*Industrial SCBA Masks	7	215 ⁰⁰	1,505 ⁰⁰
*CBRN and Riot Control Gas Masks	104	549 ⁰⁰	57,096 ⁰⁰

TOTAL: 462,683⁰⁰

*NOTE: pricing subject to twelve (12) month period, commencing on the Date of Award through one (1) year.

THE CITY OF MIDWEST CITY IS EXEMPT FROM PAYMENT OF OKLAHOMA SALES TAX AND FEDERAL EXCISE TAX.

I have examined the specifications and agree, provided I am awarded a contract within thirty (30) days from the date fixed for opening bids, to provide the above described items for the sum shown, in accordance with the terms and conditions attached to this sheet as "Agreement By Bidder."

DELIVERY WILL BE MADE IN 120 DAYS OR LESS FROM DATE OF ORDER. DATED THIS 22 DAY OF April, 2019.

FIRM CASCO INDUSTRIES, INC ^{DUE to leak cylinders} BY JEFF DAVENPORT

ADDRESS 3601 NW 10th St TITLE SALES REPRESENTATIVE
OKLAHOMA City, OK 73107

Accepted by the CITY OF MIDWEST CITY this _____ day of _____, 20_____.

Matthew Dukes, II, MAYOR

Sara Hancock, City Clerk

Approved as to form this _____ day of _____, 20_____.

Heather Poole, City Attorney

Self-Contained Breathing Apparatus (SCBA)

Tuesday, April 23, 2019

BID TAB

VENDOR

BID AMOUNT

Casco Industries, Inc.

\$ 462,683.00 (without options)

\$ 21,148.00 (additional options)

MEMO

To: Honorable Mayor and City Council

From: Bert Norton, Fire Chief

Date: May 14, 2019

Subject: Discussion and consideration of awarding the bid and entering into a contract with Tescorp for two (2) Self Contained Breathing Apparatus Air Compressor Fill Stations at \$41,576.00 each and (2) Integrated Carbon Monoxide Detectors at \$2,900.00, in the total amount of \$88,952.00, to be placed at Fire Stations No. 1 and 6.

On Tuesday, April 23, 2019, bids were opened for one (1) or more new self contained breathing apparatus fill stations. Two (2) bid packets were received. Tescorp was the lowest best bid in the base bid amount of \$41,576.00 each with an optional integrated carbon monoxide detector for \$2,900.00. The bid meets specifications and staff recommends awarding the bid with options to Tescorp in the amount of \$88,952.00.

Funding will be coming from a combination of a federal grant and general obligation bonds in the 041 Fire Department capital outlay account and 270 (2018) GO Bond account.



Bert Norton
Fire Chief

Attachments: Tescorp Bid Packet

Invitation for Sealed Bids

CITY OF MIDWEST CITY

100 N. MIDWEST BLVD.
MIDWEST CITY, OKLAHOMA 73110

Write legibly in ink or use typewriter.

Published In
The Journal Record

Dates Advertised
April 10, 2019

Bids must be in the Office of the City Clerk By:
Tuesday, April 23, 2019 no later than 2:00 p.m.

IMPORTANT: Bid envelope must indicate bid item enclosed and date of bid opening.

Description	Quantity	Unit Price	Total Net Price
New Breathing Air Compressor(s):			
ITEM 1. Price for (6) Bottle cascade deduct 2600 each for (4) Bottle	(2) Two	41,576 ⁰⁰	83,152 ⁰⁰
*ITEM 2. Price for (4) Bottle cascade *proposed item will be purchased contingent upon available funding Add 2600 For (6) Bottle	(1) One	30,505 ⁰⁰	30,505 ⁰⁰
		Option: CO monitor 1/2 2,900 ⁰⁰ Installed	

THE CITY OF MIDWEST CITY IS EXEMPT FROM PAYMENT OF OKLAHOMA SALES TAX AND FEDERAL EXCISE TAX.

I have examined the specifications and agree, provided I am awarded a contract within thirty (30) days from the date fixed for opening bids, to provide the above described items for the sum shown, in accordance with the terms and conditions attached to this sheet as "Agreement By Bidder."

DELIVERY WILL BE MADE IN 70 DAYS OR LESS FROM DATE OF ORDER. DATED THIS 20 DAY OF April, 2019.

FIRM Tescorp BY Chris M

ADDRESS PO Box 471453 Tulsa 74147 TITLE Mgr.

Accepted by the CITY OF MIDWEST CITY this _____ day of _____, 20_____.

Matthew Dukes, II, MAYOR

Sara Hancock, City Clerk

Approved as to form this _____ day of _____, 20_____.

Heather Poole, City Attorney



Toll Free: (800) 874-7719
E-Mail: sales@tescorp.com
www.tescorp.com

April 20, 2019

City of Midwest City

Attn. City Clerk

Re Fire Department Breathing air compressor bid.

Due to limited space I am including this page for additional details.

Item 1. Bauer Legacy 18 compressor, Bauer Legacy 3 fill station and a 6 bottle 6000 psi cascade.

Unit price \$41,576.00

If a 4 bottle cascade is supplied deduct \$2,600.00

Item 2. Bauer Legacy 13 compressor, Bauer Legacy2 fill station ad a 4 bottle 6000 psi cascade.

If a 6 bottle cascade is needed add \$2,600.00

There was a mention of a CO monitor option in the spec. Add \$ 2,900.00 for each monitor.

This includes installing the monitor.

Specifications for the proposed equipment are enclosed.

Note Bauer has a 24 month warranty on the entire unit and an addition 3 years on the compressor block and cooling coils.

Thank you for your consideration

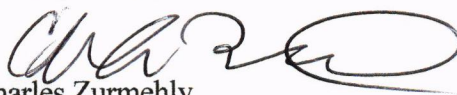
Charles Zurmehly

New Breathing Air Compressor(s)

Tuesday, April 23, 2019

BID TAB

VENDOR

BID AMOUNT

Tescorp
PO Box 471453
Tulsa, OK 74147

Item 1.
Item 2.
Optional:
CO Monitor

Unit Price: \$41,576.00
Unit Price: \$30,505.00
Unit Price: \$2,900.00

Casco Industries, Inc.
3601 NW 10th St
Oklahoma City, OK 73107

Item 1.
Item 2.

Unit Price: \$52,088.59
Unit Price: \$25,725.26



Public Works Administration
Vaughn Sullivan, Director
vsullivan@midwestcityok.org
R. Paul Streets, Assistant Director
rstreets@midwestcityok.org
8730 S.E. 15th Street,
Midwest City, Oklahoma 73110
O: 405-739-1060 /Fax: 405-739-1090

Memo

To: Honorable Mayor and Council

From: **R. Paul Streets, Assistant Public Works Director**

Date: May 14, 2019

Subject: Discussion and consideration of appointing representatives from Midwest City to an advisory committee that would oversee efforts related to a pilot study for Indirect Potable Reuse (IPR) by the City of Norman.

Several months ago, elected and appointed leadership from Midwest City, Norman, and Del City met to discuss a number of topics related to the Central Oklahoma Master Conservancy District (COMCD). The primary topic was the use of Indirect Potable Reuse (IPR) to augment Lake Thunderbird to improve water quality. During open dialogue among these key leaders, Norman mentioned the possibility of putting together a committee that had representatives from each of the cities, regulators, and educational institutions to improve the communication and facilitate transparency related to the IPR pilot study going forward. To that end, The City of Norman has officially extended an invitation to Midwest City to appoint representatives to an advisory committee that will oversee the pilot study protocol for IPR.

Participating in this process will not infer our “approval” for the use of IPR to add water to Lake Thunderbird. In fact, this will instead provide us with a front row seat to see the challenges related to implementing IPR in the State of Oklahoma, while giving us a voice in the process. But most importantly, it also gives us the opportunity to see first-hand, the impact and feasibility of IPR for future applications in Midwest City.

Staff recommends accepting the invitation from the City of Norman and appointing three representatives for the City of Midwest City to include; a staff person, elected official, and a citizen with an academic or professional background in Science.

R. Paul Streets
Assistant Public Works Director

Attached: Invitation Letter from the City of Norman



The City of
NORMAN

201 W. Gray, Bldg. C • P.O. Box 370
Norman, Oklahoma 73069 • 73070

Director of Utilities

Phone 405-366-5494

Fax 405-366-5447

E-mail; ken.komiske@normanok.gov

April 23, 2019

Mr. Matt Dukes, Mayor
City of Midwest City
100 N Midwest Boulevard
Midwest City OK 73110

Re: Advisory Committee to Norman's Indirect Potable Reuse Pilot Project

Honorable Mayor Dukes:

As we discussed some time ago, the City of Norman will be submitting a Pilot Study Protocol for Indirect Potable Reuse (IPR) to the Oklahoma Department of Quality (DEQ) for approval in the near future. We would like your help in putting together a committee of two or three members from your city to be active participants as we step through this process. The committee members should be individuals the community respects and trust but they are not required to have a technical background. The pilot study will be using different treatment processes, measuring actual results and making adjustments to improve effectiveness and efficiency. This process will continue over several seasons to insure consideration of differing water qualities and temperatures so the committee members should anticipate a two year commitment. The number of meetings, times and duration will be best defined by the committee members. It will be the committee's responsibility to communicate with the project team and their community to make sure the community's concerns are addressed.

This important project is expected to improve the water quality in Lake Thunderbird, provide drought proof resiliency, help meet the State's goal of water for 2060 and be a benefit to all of Oklahoma.

Thank you for your consideration and looking forward to working with the Advisory Committee.

Sincerely,

Kenneth Komiske

CC: Mr. Guy Henson, City Manager, Midwest City
Ms. Mary Rupp, City Manager, Norman



The City of
MIDWEST CITY
COMMUNITY DEVELOPMENT DEPARTMENT

Billy Harless, Community Development Director

ENGINEERING DIVISION
Patrick Menefee, City Engineer
CURRENT PLANNING DIVISION
Kellie Gilles, Manager
COMPREHENSIVE PLANNING
Petya Stefanoff, Comprehensive Planner
BUILDING INSPECTION DIVISION
Christine Brakefield, Building Official
GIS DIVISION
Greg Hakman, GIS Coordinator

TO : Honorable Mayor and City Council

FROM : Billy Harless, Director

DATE : May 14, 2019

SUBJECT : Discussion and consideration of appointing a replacement for Travis Jernigan to the Plumbing, Gas, and Mechanical Board. (Continued from April 23, 2019 Council meeting.)

In accordance with Sec. 9-190 of the Municipal Code, the Plumbing, Gas and Mechanical Board shall consist of six (6) members of the plumbing, gas and mechanical trade. The board members shall be appointed by the City Council for terms of three (3) years, and each shall serve until his successor is appointed and qualified, unless sooner removed for cause.

The Plumbing, Gas and Mechanical Board meets on call. Members of the Board serve 3-year terms and are as follows:

Steve Foster – Gas (expires 11.9.21)
Dale Milburn – Plumbing (expires 3.26.22)
Steve Franks – Mechanical (expires 2.9.21)
Jerry White – Mechanical (expires 2.9.21)
Gary Perkins – Plumbing (expires 3.26.22)
Vacant – Mechanical

Action is at the discretion of the Council.

Billy Harless
Community Development Director

BH:lkb



NEW BUSINESS/
PUBLIC DISCUSSION





EXECUTIVE SESSION





Assistant City Manager

100 N. Midwest Boulevard

Midwest City, OK 73110

office 405.739.1201

MEMORANDUM

TO: Honorable Mayor and Council

FROM: Tim Lyon, Assistant City Manager

DATE: May 14, 2019

RE: Discussion and consideration of (1) entering into executive session, as allowed under 25 O.S., § 307(B)(4), to discuss *Shane Campbell v. the City of Midwest City*, Case No. CM-2017-01546126A and CM-2017-01548K, and (2) in open session, authorizing the city manager to take action as appropriate based on the discussion in executive session.

Appropriate information will be provided during executive session.

Tim L. Lyon

Tim Lyon
Assistant City Manager



FURTHER INFORMATION





Police Department
100 N. Midwest Blvd.
Midwest City, OK 73110
bclabes@midwestcityok.org
Office: 405-739-1302
www.midwestcityok.org

Memorandum

TO: Honorable Mayor and Council

FROM: Brandon Clabes, Chief of Police

DATE: May 14, 2019

SUBJECT: Discussion and consideration to approve an ordinance amending the Midwest City Municipal Code, Chapter 28, Offenses, Section 28-130, Possession of dangerous drugs; Section 28-131, Possession and sale of certain toxins and other drugs prohibited, and Section 28-132, Possession or sale of drug related paraphernalia, and providing for repealer and severability.

The proposed amendment to Section 28-130 will fill an enforcement gap created by State Question 780, allowing Midwest City Police Department to charge people with possession of Schedule I and II drugs, possession of which was formerly a felony. Version 2 of 63 O.S. § 2-402(B), makes unauthorized “possession of a controlled dangerous substance a misdemeanor.” That statute also makes it unlawful to sell, market, or label products containing certain stimulants. The amendment also deletes the specific statutory reference to subsection 28 in 63 O.S. § 2-101 as where “practitioner ” is defined.

The proposed amendment to Section 28-131 removes reference to Schedule I, because that is now in 28-130. The amendment clarifies the ordinance prohibits the possession, sale, and distribution of toxic substances, which are not classified in Schedules I-V, and are used or consumed to induce a state of intoxication, hallucination, or a stimulant or depressive effect.

The proposed amendment to Section 28-132 corrects the spelling of “inhaling.”

Staff recommends approval.

Brandon Clabes, Chief of Police

1 **Sec. 28-131. Possession and sale of certain toxins and other drugs prohibited.**

2 (a) It shall be unlawful for any person to possess, sell or distribute, or for any person
3 to inhale or ingest, any compound, liquid or chemical, ~~salt, isomer and salt of isomer~~
4 ~~prohibited under the Oklahoma Controlled Dangerous Substances Act, 63 O.S. § 2-~~
5 ~~204, (OCDSA), not already prohibited under section 28-130 above,~~ including but not
6 limited to, ~~specific substances:~~

7 ~~1. intended to cause~~ prohibited therein, listed and/or defined as opiates, opium
8 derivatives, any level of a hallucinations; ~~or ogenic substance, any quantity of~~
9 substances

10 ~~2. having a stimulant or depressant effect on the central nervous system,; or~~

11 ~~3. any quantity of a synthetic chemical compounds that is a~~ are cannabinoid
12 receptor agonists, ~~which may be used or consumed by a person for the purpose~~
13 of inducing a condition of intoxication, distortion or disturbance of the
14 auditory, visual or mental processes.

15 (b) Exceptions.

16 (1) The provisions of subsection section 28-131(a) shall not apply to the
17 possession and use of the substances listed as part of the care or treatment of a
18 disease, condition or injury by a licensed physician or pursuant to a
19 prescription of a licensed physician.

20 (2) The provisions of subsection 28-131(a) shall not apply to the possession as
21 part of a known manufacturing process or industrial operation.

22
23 **Section 3.** That the Midwest City Municipal Code, Section 28-132, Possession or sale of drug
24 related paraphernalia, is hereby amended to read as follows:

25
26 **Sec. 28-132. - Possession or sale of drug related paraphernalia.**

27 (a) "Drug paraphernalia" means all equipment, products and materials of any kind
28 which are used or intended for use in planting, propagating, cultivating, growing,
29 harvesting, manufacturing, compounding, converting, producing, processing, preparing,
30 testing, analyzing, packaging, repackaging, storing, containing, concealing, injecting,
31 ingesting, ~~inhaling~~ inhaling or otherwise introducing into the human body a controlled
32 dangerous substance in violation of the Oklahoma Uniform Controlled Dangerous
33 Substance Act, Title 63, O.S., § 2-101 et seq. It includes, but is not limited to:

34 (1) Kits used or intended for use in planting, propagating, cultivating, growing
35 or harvesting of any species of plant which is a controlled dangerous substance
36 or from which a controlled dangerous substance can be derived;

37 (2) Kits used or intended for use in manufacturing, compounding, converting,
38 producing, processing or preparing controlled dangerous substances;
39 isomerization devices used or intended for use in increasing the potency of any
40 species of plant which is a controlled dangerous substances;

41 (3) Testing equipment used or intended for use in identifying, or in analyzing
42 the strength, effectiveness or purity of controlled dangerous substances; scales
43 and balances used or intended for use in weighing or measuring controlled
44 dangerous substances;

- 1 (4) Diluents and adulterants, such as quinine hydrochloride, mannitol,
2 mannite, dextrose and lactose, used or intended for use in cutting controlled
3 dangerous substances;
- 4 (5) Separation gins and sifters used or intended for use in removing twigs and
5 seeds from, or in otherwise cleaning or refining, marijuana;
- 6 (6) Blenders, bowls, containers, spoons and mixing devices used or intended
7 for use in compounding controlled dangerous substances;
- 8 (7) Capsules, balloons, envelopes and other containers used or intended for use
9 in packaging small quantities of controlled dangerous substances;
- 10 (8) Containers and other objects used or intended for use in parenthetically
11 injecting controlled dangerous substances into the human body;
- 12 (9) Hypodermic syringes, needles and other objects used or intended for use in
13 parenthetically injecting controlled dangerous substances into the human body;
- 14 (10) Objects used or intended for use in ingesting, inhaling or otherwise
15 introducing marijuana, cocaine, hashish or hashish oil into the human body,
16 such as:

- 17 a. Metal, wooden, acrylic, glass, stone, plastic or ceramic pipes with or
18 without screens, permanent screens, hashish heads or punctured metal
19 bowls;
- 20 b. Water pipes;
- 21 c. Carburetion tubes and devices;
- 22 d. Smoking and carburetion masks;
- 23 e. Roach clips: Meaning objects used to hold burning material, such as
24 a marijuana cigarette, that has become too small or too short to be held
25 in the hand;
- 26 f. Miniature cocaine spoons and cocaine vials;
- 27 g. Chamber pipes;
- 28 h. Carburetor pipes;
- 29 i. Electric pipes;
- 30 j. Air-driven pipes;
- 31 k. Chillums;
- 32 l. Bongs;
- 33 m. Ice pipes or chillers.

34 (b) In determining whether an object is "drug paraphernalia," consider, in addition to
35 all other logically relevant factors, the following:

- 36 (1) Statements by an owner or by anyone in control of the object concerning its
37 use;
- 38 (2) The proximity of the object, in time and space, to a direct violation of the
39 Uniform Controlled Dangerous Substances Act (63 O.S., § 2-101 et seq.);
- 40 (3) The proximity of the object to controlled dangerous substances;
- 41 (4) The existence of any residue of controlled dangerous substances on the
42 object;
- 43 (5) Instructions, oral or written, provided with the object which either state
44 directly or imply that the object is to be used for the consumption of controlled
45 substances;

- 1 (6) Descriptive materials accompanying the object which explain or depict its
2 use as an object for the consumption of controlled substances;
3 (7) The manner in which the object is displayed for sale;
4 (8) Whether the owner, or anyone in control of the object, is a legitimate
5 supplier of like or related items to the community, such as a licensed
6 distributor or dealer of tobacco products;
7 (9) The existence and scope of legitimate uses for the object in the community.

8 (c) It shall be unlawful for any person to use or possess drug paraphernalia to plant,
9 propagate, cultivate, grow, harvest, manufacture, compound, convert, produce,
10 process, prepare, test, analyze, pack, repack, store, contain, conceal, inject, ingest,
11 inhale or otherwise introduce into the human body a controlled dangerous substance in
12 violation of the Uniform Controlled Dangerous Substances Act (63 O.S., § 2-101 et
13 seq.), except those persons holding an unrevoked license in the professions of
14 podiatry, dentistry, medicine, nursing, optometry, osteopathy, veterinary medicine or
15 pharmacy.

16 (d) It shall be unlawful for any person to deliver, possess or manufacture drug
17 paraphernalia knowing it will be used to plant, propagate, cultivate, grow, harvest,
18 manufacture, compound, convert, produce, process, prepare, test, analyze, pack,
19 repack, store, contain, conceal, inject, ingest, inhale or otherwise introduce into the
20 human body a controlled dangerous substance in violation of the Uniform Controlled
21 Dangerous Substances Act (63 O.S., § 2-101 et seq.).

22 (e) It shall be unlawful for any person to operate a business within the limits of the
23 city known as, or commonly referred to as, a "head shop," which place of business is
24 patronized and frequented by narcotic drug addicts and whose merchandise is those
25 items described in subsection (a) of this section.

26
27 **Section 4. REPEALER.** All ordinances or parts of ordinances in conflict herewith are hereby
28 repealed.
29

30 **Section 5. SEVERABILITY.** If any section, sentence, clause, or portion of this ordinance is for
31 any reason held to be invalid, such decision shall not affect the validity of the remaining
32 provisions of the ordinance.
33

34 PASSED AND APPROVED by the Mayor and the Council of the City of Midwest City,
35 Oklahoma, this _____ day of April, 2019.

36
37 THE CITY OF MIDWEST CITY, OKLAHOMA
38

39
40 ATTEST:

41 _____
42 MATTHEW D. DUKES, II, Mayor

43 _____
44 SARA HANCOCK, City Clerk

45 Approved as to form and legality this _____ day of April, 2019.
46

HEATHER POOLE, City Attorney

1 (a) It shall be unlawful for any person to possess, sell or distribute, or for any person
2 to inhale or ingest, any compound, liquid or chemical, including but not limited to
3 substances:

- 4 1. intended to cause hallucinations;
- 5 2. having a stimulant or depressant effect on the central nervous system; or
- 6 3. synthetic chemical compounds that are cannabinoid receptor agonists, used
7 or consumed by a person for the purpose of inducing a condition of
8 intoxication, distortion or disturbance of the auditory, visual or mental
9 processes.

10 (b) Exceptions.

11 (1) The provisions of subsection section 28-131(a) shall not apply to the
12 possession and use of the substances listed as part of the care or treatment of a
13 disease, condition or injury by a licensed physician or pursuant to a
14 prescription of a licensed physician.

15 (2) The provisions of subsection 28-131(a) shall not apply to the possession as
16 part of a known manufacturing process or industrial operation.

17
18 **Section 3.** That the Midwest City Municipal Code, Section 28-132, Possession or sale of drug
19 related paraphernalia, is hereby amended to read as follows:

20
21 **Sec. 28-132. Possession or sale of drug related paraphernalia.**

22 (a) "Drug paraphernalia" means all equipment, products and materials of any kind
23 which are used or intended for use in planting, propagating, cultivating, growing,
24 harvesting, manufacturing, compounding, converting, producing, processing, preparing,
25 testing, analyzing, packaging, repackaging, storing, containing, concealing, injecting,
26 ingesting, inhaling or otherwise introducing into the human body a controlled
27 dangerous substance in violation of the Oklahoma Uniform Controlled Dangerous
28 Substance Act, Title 63, O.S., § 2-101 et seq. It includes, but is not limited to:

29 (1) Kits used or intended for use in planting, propagating, cultivating, growing
30 or harvesting of any species of plant which is a controlled dangerous substance
31 or from which a controlled dangerous substance can be derived;

32 (2) Kits used or intended for use in manufacturing, compounding, converting,
33 producing, processing or preparing controlled dangerous substances;
34 isomerization devices used or intended for use in increasing the potency of any
35 species of plant which is a controlled dangerous substances;

36 (3) Testing equipment used or intended for use in identifying, or in analyzing
37 the strength, effectiveness or purity of controlled dangerous substances; scales
38 and balances used or intended for use in weighing or measuring controlled
39 dangerous substances;

40 (4) Diluents and adulterants, such as quinine hydrochloride, mannitol,
41 mannite, dextrose and lactose, used or intended for use in cutting controlled
42 dangerous substances;

43 (5) Separation gins and sifters used or intended for use in removing twigs and
44 seeds from, or in otherwise cleaning or refining, marijuana;

45 (6) Blenders, bowls, containers, spoons and mixing devices used or intended
46 for use in compounding controlled dangerous substances;

1 (7) Capsules, balloons, envelopes and other containers used or intended for use
2 in packaging small quantities of controlled dangerous substances;

3 (8) Containers and other objects used or intended for use in parenthetically
4 injecting controlled dangerous substances into the human body;

5 (9) Hypodermic syringes, needles and other objects used or intended for use in
6 parenthetically injecting controlled dangerous substances into the human body;

7 (10) Objects used or intended for use in ingesting, inhaling or otherwise
8 introducing marijuana, cocaine, hashish or hashish oil into the human body,
9 such as:

10 a. Metal, wooden, acrylic, glass, stone, plastic or ceramic pipes with or
11 without screens, permanent screens, hashish heads or punctured metal
12 bowls;

13 b. Water pipes;

14 c. Carburetion tubes and devices;

15 d. Smoking and carburetion masks;

16 e. Roach clips: Meaning objects used to hold burning material, such as
17 a marijuana cigarette, that has become too small or too short to be held
18 in the hand;

19 f. Miniature cocaine spoons and cocaine vials;

20 g. Chamber pipes;

21 h. Carburetor pipes;

22 i. Electric pipes;

23 j. Air-driven pipes;

24 k. Chillums;

25 l. Bongs;

26 m. Ice pipes or chillers.

27 (b) In determining whether an object is "drug paraphernalia," consider, in addition to
28 all other logically relevant factors, the following:

29 (1) Statements by an owner or by anyone in control of the object concerning its
30 use;

31 (2) The proximity of the object, in time and space, to a direct violation of the
32 Uniform Controlled Dangerous Substances Act (63 O.S., § 2-101 et seq.);

33 (3) The proximity of the object to controlled dangerous substances;

34 (4) The existence of any residue of controlled dangerous substances on the
35 object;

36 (5) Instructions, oral or written, provided with the object which either state
37 directly or imply that the object is to be used for the consumption of controlled
38 substances;

39 (6) Descriptive materials accompanying the object which explain or depict its
40 use as an object for the consumption of controlled substances;

41 (7) The manner in which the object is displayed for sale;

42 (8) Whether the owner, or anyone in control of the object, is a legitimate
43 supplier of like or related items to the community, such as a licensed
44 distributor or dealer of tobacco products;

45 (9) The existence and scope of legitimate uses for the object in the community.

1 (c) It shall be unlawful for any person to use or possess drug paraphernalia to plant,
2 propagate, cultivate, grow, harvest, manufacture, compound, convert, produce,
3 process, prepare, test, analyze, pack, repack, store, contain, conceal, inject, ingest,
4 inhale or otherwise introduce into the human body a controlled dangerous substance in
5 violation of the Uniform Controlled Dangerous Substances Act (63 O.S., § 2-101 et
6 seq.), except those persons holding an unrevoked license in the professions of
7 podiatry, dentistry, medicine, nursing, optometry, osteopathy, veterinary medicine or
8 pharmacy.

9 (d) It shall be unlawful for any person to deliver, possess or manufacture drug
10 paraphernalia knowing it will be used to plant, propagate, cultivate, grow, harvest,
11 manufacture, compound, convert, produce, process, prepare, test, analyze, pack,
12 repack, store, contain, conceal, inject, ingest, inhale or otherwise introduce into the
13 human body a controlled dangerous substance in violation of the Uniform Controlled
14 Dangerous Substances Act (63 O.S., § 2-101 et seq.).

15 (e) It shall be unlawful for any person to operate a business within the limits of the
16 city known as, or commonly referred to as, a "head shop," which place of business is
17 patronized and frequented by narcotic drug addicts and whose merchandise is those
18 items described in subsection (a) of this section.

19
20 **Section 4. REPEALER.** All ordinances or parts of ordinances in conflict herewith are hereby
21 repealed.
22

23 **Section 5. SEVERABILITY.** If any section, sentence, clause, or portion of this ordinance is for
24 any reason held to be invalid, such decision shall not affect the validity of the remaining
25 provisions of the ordinance.
26

27 PASSED AND APPROVED by the Mayor and the Council of the City of Midwest City,
28 Oklahoma, this _____ day of April, 2019.

29
30 THE CITY OF MIDWEST CITY, OKLAHOMA

31
32
33
34 _____
35 MATTHEW D. DUKES, II, Mayor

36 ATTEST:

37
38 _____
39 SARA HANCOCK, City Clerk

40
41 Approved as to form and legality this _____ day of April, 2019.

42
43
44 _____
45 HEATHER POOLE, City Attorney
46

State Question No. 780, Initiative Pe

The relevant portion is Section 3,
so only pages 1 and 2 are provided.

WARNING

IT IS A FELONY FOR ANYONE TO SIGN AN INITIATIVE OR REFERENDUM PETITION WITH ANY NAME OTHER THAN HIS OWN, OR KNOWINGLY TO SIGN HIS NAME MORE THAN ONCE FOR THE MEASURE, OR TO SIGN THE PETITION WHEN HE IS NOT A LEGAL VOTER.

INITIATIVE PETITION

To the Honorable Mary Fallin, Governor of Oklahoma:

We, the undersigned legal voters of the State of Oklahoma, respectfully order that the following proposed law shall be submitted to the legal voters of the State of Oklahoma for their approval or rejection at the regular general election, to be held on the 8th day of November, 2016 (or at a special election as may be called by the Governor), and each for himself says: I have personally signed this petition; I am a legal voter of the State of Oklahoma; my residence or post office are correctly written after my name. The time for filing this petition expires ninety (90) days from _____. The question we herewith submit to our fellow voters is:

Shall the following bill be approved?

An Act relating to criminal justice reform for low-level offenses: stating factual findings and intent for the Act; amending 63 O.S. 2011, Section 2-402, relating to offenses involving controlled substances; amending 21 O.S. 2011, Sections 1704, 1705, 1713, 1719.1, 1722, 1731, relating to larceny; amending 21 O.S. 2011, Sections 1451, 1503, 1521, 1541.1, 1541.2, and 1541.3, relating to property offenses involving embezzlement or false pretenses; amending 59 O.S. 2011, Section 1512, relating to pawnbrokers; amending 21 O.S. 2011, Sections 1577, 1578, 1579, and 1621, relating to offenses involving forgery or counterfeiting; repealing 21 O.S. 2011, Section 51.3, related to punishments for second and subsequent offenses; providing for severability; and providing an effective date.

BE IT ENACTED BY THE PEOPLE OF THE STATE OF OKLAHOMA:

SECTION 1. The people of the state of Oklahoma find the fact that Oklahoma has the second-highest overall incarceration rate in the country, and the highest incarceration rate for women, is inconsistent with Oklahoma values, and drains resources away from investments that can do more to promote public safety. Therefore, the people intend, in enacting this initiative measure, to implement criminal justice reforms that: (1) stop wasting taxpayer money keeping people who commit low-level offenses behind bars for years; and (2) saddle fewer people who commit low-level offenses with felony convictions that will follow them through life and prevent them from getting an education or a job.

SECTION 2. This act shall be known and may be cited as the "Oklahoma Smart Justice Reform Act."

SECTION 3. AMENDATORY 63 O.S. 2011, Section 2-402, last amended by Section 10, Chapter 228, O.S.L. 2012 (63 O.S. Supp. 2012. Section 2-402), is amended to read as follows:

Section 2-402. A. 1. It shall be unlawful for any person knowingly or intentionally to possess a controlled dangerous substance unless such substance was obtained directly, or pursuant to a valid prescription or order from a practitioner, while acting in the course of his or her professional practice, or except as otherwise authorized by this act.

2. It shall be unlawful for any person to purchase any preparation excepted from the provisions of the Uniform Controlled Dangerous Substances Act pursuant to Section 2-313 of

The relevant portion is Section 3,
so only pages 1 and 2 are provided.

this title in an amount or within a time interval other than that permitted by Section 2-313 of this title.

3. It shall be unlawful for any person or business to sell, market, advertise or label any product containing ephedrine, its salts, optical isomers, or salts of optical isomers, for the indication of stimulation, mental alertness, weight loss, appetite control, muscle development, energy or other indication which is not approved by the pertinent federal OTC Final Monograph, Tentative Final Monograph, or FDA-approved new drug application or its legal equivalent. In determining compliance with this requirement, the following factors shall be considered:

- a. the packaging of the product,
- b. the name of the product, and
- c. the distribution and promotion of the product, including verbal representations made at the point of sale.

B. Any person who violates this section is guilty of a misdemeanor punishable by confinement for not more than one (1) year and by a fine not exceeding One Thousand Dollars (\$1,000.00).

C. Any person convicted of any offense described in this section shall, in addition to any fine imposed, pay a special assessment trauma-care fee of One Hundred Dollars (\$100.00) to be deposited into the Trauma Care Assistance Revolving Fund created in Section 1-2530.9 of this title.

SECTION 4. AMENDATORY 21 O.S. 2011, Section 1704 is amended to read as follows:

Section 1704. Grand larceny is larceny committed in either of the following cases:

1. When the property taken is of value exceeding One Thousand Dollars (\$1,000.00).
2. When such property, although not of value exceeding One Thousand Dollars (\$1,000.00), is taken from the person of another.

Larceny in other cases is petit larceny.

SECTION 5. AMENDATORY 21 O.S. 2011, Section 1705 is amended to read as follows:

Section 1705. Grand larceny is a felony punishable by imprisonment in the State Penitentiary not exceeding five (5) years if the value of the property is One Thousand Dollars (\$1,000.00) or more and if the value of the property is less than One Thousand Dollars (\$1,000.00) punishable by incarceration in the county jail for not more than one (1) year or by incarceration in the county jail one or more nights or weekends pursuant to Section 991a-2 of Title 22 of the Oklahoma Statutes, at the option of the court, and shall be subject to a fine of not more than Five Thousand Dollars (\$5,000.00) and ordered to provide restitution to the victim as provided in Section 991a of Title 22 of the Oklahoma Statutes.

SECTION 6. AMENDATORY 21 O.S. 2011, Section 1713 is amended to read as follows:

Section 1713. A. Every person who buys or receives, in any manner, upon any consideration, any personal property of any value whatsoever that has been stolen, embezzled, obtained by false pretense or robbery, knowing or having reasonable cause to believe the same to have been stolen, embezzled, obtained by false pretense, or robbery, or who conceals, withholds, or aids in concealing or withholding such property from the owner, shall, if the value of the property is One Thousand Dollars (\$1,000.00) or more be guilty of a felony punishable by imprisonment in the State Penitentiary not to exceed five (5) years, or in the county jail not to exceed one (1) year, or by a fine not to exceed Five Hundred Dollars (\$500.00) or by both such fine and imprisonment. If the value of the property received is less than One Thousand Dollars (\$1,000.00), the person shall be guilty of a misdemeanor and shall be punished by a fine of not more than Five Hundred Dollars (\$500.00) or by imprisonment in the county jail for a term not to exceed six (6) months, or by both such fine and imprisonment.

B. Every person who, without making reasonable inquiry, buys, receives, conceals, withholds, or aids in concealing or withholding any property which has been stolen, embezzled, obtained by false pretense or robbery, or otherwise feloniously obtained, under such circumstances as should cause such person to make reasonable inquiry to ascertain that the person from whom such property was bought or received had the legal right to sell or deliver it



OKLAHOMA

State Courts Network

Title 63. Public Health and Safety

Oklahoma Statutes Citationized

Title 63. Public Health and Safety

Chapter 2 - Uniform Controlled Dangerous Substances Act

Article Article 4 - Penalties - Offenses

Section 2-402 - Prohibited Acts B - Penalties

Cite as: O.S. §. ___

Multiple Amendments Enacted in 2016

Version 1 (as amended by Laws 2016, HB 2479, c. 220, § 1, eff. November 1, 2016)

A. 1. It shall be unlawful for any person knowingly or intentionally to possess a controlled dangerous substance unless such substance was obtained directly, or pursuant to a valid prescription or order from a practitioner, while acting in the course of his or her professional practice, or except as otherwise authorized by this act.

2. It shall be unlawful for any person to purchase any preparation excepted from the provisions of the Uniform Controlled Dangerous Substances Act pursuant to Section 2-313 of this title in an amount or within a time interval other than that permitted by Section 2-313 of this title.

3. It shall be unlawful for any person or business to sell, market, advertise or label any product containing ephedrine, its salts, optical isomers, or salts of optical isomers, for the indication of stimulation, mental alertness, weight loss, appetite control, muscle development, energy or other indication which is not approved by the pertinent federal OTC Final Monograph, Tentative Final Monograph, or FDA-approved new drug application or its legal equivalent. In determining compliance with this requirement, the following factors shall be considered:

- a. the packaging of the product,
- b. the name of the product, and
- c. the distribution and promotion of the product, including verbal representations made at the point of sale.

B. Any person who violates this section with respect to:

1. Any Schedule I or II substance, except marijuana or a substance included in subsection D of Section 2-206 of this title, is guilty of a felony punishable by imprisonment for not more than five (5) years and by a fine not exceeding Five Thousand Dollars (\$5,000.00). A second violation of this section with respect to a Schedule I or II substance, except marijuana or a substance included in subsection D of Section 2-206 of this title, is a felony punishable by imprisonment for not more than ten (10) years and by a fine not exceeding Ten Thousand Dollars (\$10,000.00). A third or subsequent violation of this section with respect to a Schedule I or II substance, except marijuana or a substance included in subsection D of Section 2-206 of this title, is a felony punishable by imprisonment for not less than four (4) years nor more than fifteen (15) years and by a fine not exceeding Ten Thousand Dollars (\$10,000.00);

2. Any Schedule III, IV or V substance, marijuana, a substance included in subsection D of Section 2-206 of this title, or any preparation excepted from the provisions of the Uniform Controlled Dangerous Substances Act is guilty of a misdemeanor punishable by confinement for not more than one (1) year and by a fine not exceeding One Thousand Dollars (\$1,000.00);

3. Any Schedule III, IV or V substance, marijuana, a substance included in subsection D of Section 2-206 of this title, or any preparation excepted from the provisions of the Uniform Controlled Dangerous Substances Act and who, during the period of any court-imposed probationary term or within ten (10) years of the date following the completion of the execution of any sentence or deferred judgment for a violation of this section, commits a second or subsequent violation of this section shall, upon conviction, be guilty of a felony punishable by imprisonment in the custody of the Department of Corrections for not less than one (1) year nor more than five (5) years and by a fine not exceeding Five Thousand Dollars (\$5,000.00); or

4. Any Schedule III, IV or V substance, marijuana, a substance included in subsection D of Section 2-206 of this title, or any preparation excepted from the provisions of the Uniform Controlled Dangerous Substances Act and who, ten (10) or more years following the date of completion of the execution of any sentence or deferred judgment for a violation of this section, commits a second or subsequent violation of this section shall, upon conviction, be guilty of a felony punishable by imprisonment in the custody of the Department of Corrections for not less than one (1) year nor more than five (5) years and by a fine not exceeding Five Thousand Dollars (\$5,000.00).

C. Any person who violates any provision of this section by possessing or purchasing a controlled dangerous substance from any person, in or on, or within one thousand (1,000) feet of the real property comprising a public or private elementary or secondary school, public vocational school, public or private college or university, or other institution of higher education, recreation center or public park, including state parks and recreation areas, or in the presence of any child under twelve (12) years of age, shall be guilty of a felony and punished by:

1. For a first offense, a term of imprisonment, or by the imposition of a fine, or by both, not exceeding twice that authorized by the appropriate provision of this section. In addition, the person shall serve a minimum of fifty percent (50%) of the sentence received prior to becoming eligible for state correctional institution earned credits toward the completion of said sentence; or

2. For a second or subsequent offense, a term of imprisonment not exceeding three times that authorized by the appropriate provision of this section and the person shall serve a minimum of ninety percent (90%) of the sentence received prior to becoming eligible for state correctional institution earned credits toward the completion of said sentence, and imposition of a fine not exceeding Ten Thousand Dollars (\$10,000.00).

D. Any person convicted of any offense described in this section shall, in addition to any fine imposed, pay a special assessment trauma-care fee of One Hundred Dollars (\$100.00) to be deposited into the Trauma Care Assistance Revolving Fund created in Section 1-2530.9 of this title.

Version 2 (as amended by Section 3, State Question 780, Initiative Petition 404, adopted at election held November 8, 2016, effective July 1, 2017)

1. It shall be unlawful for any person knowingly or intentionally to possess a controlled dangerous substance unless such substance was obtained directly, or pursuant to a valid prescription or order from a practitioner, while acting in the course of his or her professional practice, or except as otherwise authorized by this act.

2. It shall be unlawful for any person to purchase any preparation excepted from the provisions of the Uniform Controlled Dangerous Substances Act pursuant to Section 2-313 of this title in an amount or within a time interval other than that permitted by Section 2-313 of this title.

3. It shall be unlawful for any person or business to sell, market, advertise or label any product containing ephedrine, its salts, optical isomers, or salts of optical isomers, for the indication of stimulation, mental alertness, weight loss, appetite control, muscle development, energy or other indication which is not approved by the pertinent federal OTC Final Monograph, Tentative Final Monograph, or FDA-approved new drug application or its legal equivalent. In determining compliance with this requirement, the following factors shall be considered:

- a. the packaging of the product,
- b. the name of the product, and
- c. the distribution and promotion of the product, including verbal representations made at the point of sale.

B. Any person who violates this section is guilty of a misdemeanor punishable by confinement for not more than one (1) year and by a fine not exceeding One Thousand Dollars (\$1,000.00).

C. Any person convicted of any offense described in this section shall, in addition to any fine imposed, pay a special assessment trauma-care fee of One Hundred Dollars (\$100.00) to be deposited into the Trauma Care Assistance Revolving Fund created in Section 1-2530.9 of this title.

Historical Data

Laws 1971, HB 1100, c. 119, § 2-402; Amended by Laws 1972, HB 1546, c. 229, § 5, emerg. eff. April 7, 1972; Amended by Laws 1981, HB 1160, c. 34, § 1, eff. November 1, 1981; Amended by Laws 1984, HB 1708, c. 127, § 6, eff. November 1, 1984; Amended by Laws 1987, HB 1315, c. 138, § 7, emerg. eff. June 19, 1987; Amended by Laws 1992, HB 1969, c. 86, § 2, eff. September 1, 1992; Amended by Laws 1993, SB 56, c. 311, § 1, emerg. eff. June 7, 1993; Amended by Laws 1995, HB 1532, c. 147, § 3, eff. November 1, 1995; Amended by Laws 1997, HB 1213, c. 133, § 530 (eff. date amended to July 1, 1999, by Laws 1998, 1st Extr. Sess., HB 1002, c. 2, §§ 23-26, emerg. eff. June 19, 1998) (superseded document available); Amended by Laws 1999, 1st Extr. Sess., HB 1009, c. 5, § 382, emerg. eff. July 1, 1999 (superseded document available); Amended by Laws 2004, HB 2600, c. 396, § 3, eff. November 1, 2004 (effective date changed to September 1, 2004, by Laws 2004, SB 973, c. 530, § 2, eff. September 1, 2004) (superseded document available); Amended by Laws 2009, HB 1707, c. 306, § 1, eff. November 1, 2009 (superseded document available); Amended by Laws 2012, HB 3052, c. 228, § 10, eff. November 1, 2012 (superseded document available); Amended by Laws 2016, HB 2479, c. 220, § 1, eff. November 1, 2016 (superseded document available); Amended by Section 3, State Question 780, Initiative Petition 404, adopted at election held November 8, 2016, effective July 1, 2017 (superseded document available).

Citationizer® Summary of Documents Citing This Document

<i>Cite Name</i>	<i>Level</i>
Oklahoma Court of Criminal Appeals Cases	
<i>Cite</i>	<i>Name</i> <i>Level</i>
<u>2017 OK CR 15, 400 P.3d 887</u>	<u>ASHTON v. STATE</u> Cited
<u>2018 OK CR 4, 419 P.3d 257</u>	<u>SMITH v. STATE</u> Cited
<u>2018 OK CR 33, 431 P.3d 985</u>	<u>BIVENS v. STATE</u> Discussed at Length
Oklahoma Supreme Court Cases	

Cite Name	Level	
<i>Cite</i>	<i>Name</i>	<i>Level</i>
<u>2017 OK 98</u>	<u>STATE ex rel. OKLAHOMA BAR ASSOCIATION v. BOUNDS</u>	<i>Cited</i>

Citationizer: Table of Authority

Cite **Name Level**

None Found.



City Attorney
100 N. Midwest Boulevard
Midwest City, OK 73110
Office 405.739.1302
hpoole@midwestcityok.org

MEMORANDUM

TO: Honorable Mayor and City Council

FROM: Heather Poole, City Attorney

DATE: May 14, 2019

SUBJECT: Presentation of information by Dana Brockway, Executive Committee Legal Redress, NAACP Oklahoma City Branch

The NAACP has been requested to provide a more in depth overview of the issues that were raised by Ms. Brockway regarding DHS policies and procedures related to reunification of families during the public comment portion of the April 23, 2019 council meeting.

The presentation Ms. Brockway is providing is for further information only as the City itself does not have standing to participate in a proposed suit against the state agency. However, this does allow any Council members to ask questions regarding the matter while Ms. Brockway is before the Council.

No action. For Further Information only.

Respectfully,

City Attorney
Heather Poole

DON'T LOOK BACK!!!

RAISE YOUR VOICE !!!



AGENDA

- ❖ **THE PINNACLE PLAN – WHAT IS IT AND IS IT WORKING?**
- ❖ **THE FOSTER CARE SYSTEM– THE NUMBERS DON'T LIE!**
- ❖ **RAISE YOUR VOICE – WHAT WE ARE DOING TO EDUCATE AND FOSTER CHANGE!**
- ❖ **DISCUSSION – CAN WE TALK ABOUT IT?**

THE PINNACLE PLAN

WHAT IS IT AND IS IT WORKING?

THE PINNACLE PLAN

- ❖ **CHILD WELFARE PROFESSIONALS WORK TO KEEP FAMILIES TOGETHER WHEN SAFELY POSSIBLE. WHEN THIS IS NOT POSSIBLE, THEY SEARCH FOR RELATIVES AND RESOURCE PARENTS TO SUPPORT CHILDREN AND FAMILIES SO REUNIFICATION CAN HAPPEN. WHEN REUNIFICATION IS NOT POSSIBLE, THEY WORK TO PLACE CHILDREN WITH FAMILIES WHERE THEY CAN LEAD SAFE, HEALTHY LIVES AND MAINTAIN CONNECTIONS TO THEIR KIN, CULTURE, AND COMMUNITY.**
- ❖ **OKDHS LEADERSHIP DEVELOPED THE PINNACLE PLAN TO PROVIDE A CLEAR AND ACTION-ORIENTED PLAN FOR IMPROVING THE LIVES OF CHILDREN, YOUTH, AND FAMILIES SERVED BY THE CHILD WELFARE SYSTEM.**

THE PINNACLE PLAN

- ❖ **ON JANUARY 4, 2012, THE OKLAHOMA DEPARTMENT OF HUMAN SERVICES (OKDHS), JOINTLY WITH THE GOVERNOR'S OFFICE AND THE OKLAHOMA COMMISSION FOR HUMAN SERVICES, REACHED AN AGREEMENT WITH THE PLAINTIFFS IN CLASS ACTION LITIGATION DG VS. YARBROUGH, CASE NO. 08-CV-074.**
- ❖ **AS PART OF THIS AGREEMENT, OKDHS WAS TO DEVELOP AN IMPROVEMENT PLAN FOR CHILD WELFARE SERVICES CALLED THE PINNACLE PLAN.**
- ❖ **THE PINNACLE PLAN DETAILS A FIVE-YEAR PLAN, BEGINNING WITH STATE FISCAL YEAR (SFY) 2013, TO ADDRESS 15 PERFORMANCE AREAS IDENTIFIED IN THE AGREEMENT.**

THE PINNACLE PLAN

❖ **PINNACLE PLAN INITIATIVES ARE BASED ON A SET OF NEW CORE COMMITMENTS THAT REPRESENT THE FOUNDATION OF REFORM. THESE INCLUDE, BUT ARE NOT LIMITED TO:**

- **EXPANSION OF RESOURCE HOMES**
- **NEW CASELOAD STANDARDS**
- **REDUCTION IN USE OF SHELTER CARE**
- **TERMINATION OF SHELTER CARE FOR YOUNG CHILDREN**
- **CONSISTENT AND TIMELY INVESTIGATIONS AND REPORTING OF CHILD MALTREATMENT IN CARE**
- **EFFECTIVE AND STREAMLINED STAFF HIRING AND TRAINING**

OKDHS COMMITMENTS THROUGH THE PINNACLE PLAN:

- **equity, where all children, youth, and families have access to and receive unbiased treatment and services**
- **keeping children safe with their families through prevention services, kinship placements, and timely reunification whenever possible**
- **ensuring every child is safe while in out-of-home care and custody by recruiting, retaining, and supporting resource families who best match the needs of the children and can provide for their safety, permanency, and well-being**
- **moving to a continuum of care that best meets the needs of children in out-of-home care and provides for the least restrictive family-like placements, except in extraordinary circumstances**
- **recruiting, retaining, and supporting the best child welfare staff through a commitment to ongoing staff development and ensuring manageable caseloads and workloads**
- **engaging local communities and agency partners in improving child welfare outcomes**

“

THERE SHOULDN'T BE WHERE CHILDREN GET RETURNED HOME WITH BRUISES, HERPES, SORES. YOU BECOME MORE DAMAGED IN THE SYSTEM WHEN THERE ARE VALUABLE KINSHIP PLACEMENTS ABLE TO TAKE PLACEMENTS OF THESE CHILDREN,

”

DANA BROCKWAY

THE FOSTER CARE SYSTEM

THE NUMBERS DON'T LIE!

THE FOSTER CARE SYSTEM

- **THERE ARE NEARLY 9,600 CHILDREN IN STATE CUSTODY IN OKLAHOMA.**
- **OF THE NUMBER OF KIDS IN STATE CUSTODY, BETWEEN 55-65 PERCENT COMING INTO FOSTER CARE ARE PLACED WITH THEIR EXTENDED FAMILY AND FRIENDS. THE REMAINING PERCENTAGE OF CHILDREN NEED RECRUITED FOSTER HOMES OR HIGHER LEVELS OF CARE LIKE GROUP HOMES OR IN-PATIENT TREATMENT.**
- **THERE ARE MORE THAN 350 CHILDREN ON ANY GIVEN DAY WHO ARE LEGALLY FREE AND WAITING FOR ADOPTIVE FAMILIES. MORE THAN 1,000 CHILDREN IN STATE CUSTODY HAVE A GOAL OF ADOPTION.**
- **MORE THAN 60 PERCENT OF CHILDREN IN FOSTER CARE ARE UNDER THE AGE OF 12 AND MOST HAVE BROTHERS AND SISTERS ALSO IN CARE.**
- **THE GOAL IS TO REUNITE CHILDREN WITH THEIR FAMILIES WHEN THAT IS SAFELY POSSIBLE. MORE THAN 50 PERCENT OF CHILDREN WHO COME INTO STATE CUSTODY ARE REUNITED WITH THEIR FAMILIES. WHEN CHILDREN CANNOT GO HOME, DHS SEARCHES FOR ADOPTIVE FAMILIES.**
- **THE MAJORITY OF CHILDREN ADOPTED EACH YEAR ARE ADOPTED BY THEIR FOSTER FAMILIES**

THE FOSTER CARE SYSTEM

Location	Data Type	2012	2013	2014	2015	2016	2017
Oklahoma	Number	8,887	9,975	11,403	10,880	9,938	9,854
	Rate	9.5	10.6	12.0	11.3	10.3	10.3

Definitions: The number and rate per 1,000, of children under age 18 in the family foster care system in Oklahoma during each State Fiscal Year (SFY).

Data Source: Foster Care data provided by the Oklahoma Department of Human Services (OKDHS). Population data is from the U.S. Bureau of the Census, Population Estimates Division for each year.

THE FOSTER CARE SYSTEM

- **ACCORDING TO THE U.S. DEPARTMENT OF HEALTH AND HUMAN SERVICES, ADMINISTRATION FOR CHILDREN AND FAMILIES, ADMINISTRATION ON CHILDREN, YOUTH AND FAMILIES, CHILDREN'S BUREAU. (2018). CHILD MALTREATMENT 2016: REPORTS FROM THE STATES TO THE NATIONAL CHILD ABUSE AND NEGLECT DATA SYSTEM: TABLE 4-2: CHILD FATALITIES, 2012-2016. RETRIEVED FEBRUARY 06, 2018 FROM [HTTP://WWW.ACF.HHS.GOV/SITES/DEFAULT/FILES/CB/CM2014.PDF](http://www.acf.hhs.gov/sites/default/files/cb/cm2014.pdf), THERE WERE 31 CHILD DEATHS RESULTING FROM ABUSE OR NEGLECT REPORTED IN OKLAHOMA.**

THE FOSTER CARE SYSTEM

- **FOR FFY 2017, A NATIONAL ESTIMATE OF 1,720 CHILDREN DIED FROM ABUSE AND NEGLECT AT A RATE OF 2.32 PER 100,000 CHILDREN IN THE POPULATION. THE 2017 NATIONAL ESTIMATE IS AN 11.0 PERCENT INCREASE FROM THE 2013 NATIONAL ESTIMATE OF 1,550.**
- **SEVENTY-TWO PERCENT (71.8%) OF ALL CHILD FATALITIES ARE YOUNGER THAN 3 YEARS OLD. NEARLY ONE-HALF (49.6%) OF CHILD FATALITIES ARE YOUNGER THAN 1 YEAR OLD AND DIED AT A RATE OF 21.92 PER 100,000 CHILDREN IN THE POPULATION OF THE SAME AGE. THIS IS NEARLY 4 TIMES THE FATALITY RATE FOR 1-YEAR-OLD CHILDREN (5.72 PER 100,000 CHILDREN IN THE POPULATION OF THE SAME AGE). THE CHILD FATALITY RATES MOSTLY DECREASE WITH AGE. THE YOUNGER CHILDREN ARE THE MOST VULNERABLE TO DEATH AS THE RESULT OF CHILD ABUSE AND NEGLECT.**
- **BOYS HAVE A HIGHER CHILD FATALITY RATE THAN GIRLS; 2.68 PER 100,000 BOYS IN THE POPULATION, COMPARED WITH 2.02 PER 100,000 GIRLS IN THE POPULATION.**

(CHILD MISTREATMENT 2017)

**“ PEOPLE SHOULD NOT BE DEAD,
CHILDREN SHOULD NOT BE HURT
AND HARMED, AND THEN YOU’RE
STILL GETTING MONEY ON TOP
OF IT ”**

DANA BROCKWAY

RAISE YOUR VOICE

WHAT WE ARE DOING TO EDUCATE AND FOSTER CHANGE!

Senate Finds 86 Children Died In Care Of Giant For-Profit Foster Care Firm, Citing BuzzFeed News

Two years after a BuzzFeed News investigation, the Senate introduces the Child Welfare and Accountability Act to track foster care contractors.

Posted on October 18, 2017, at 9:04 a.m.



Fostering Profits

A BuzzFeed News investigation identified deaths, sex abuse, and blunders in screenin

and overseeing foster parents at the nation's largest for-profit foster care

bruary 20, 2015, at 11:52 a.m.

[Aram Roston](#)
BuzzFeed News Reporter

[Jeremy Singer-Vine](#)
BuzzFeed News Reporter

The Brief Life and Private Death of Alexandria Hill

When the government took her from her family, it outsourced her safety to a for-profit corporation. Nine months later she was dead.

BRIAN JOSEPH FEB. 26, 2015 11:00 AM



Foster Care Company's "Abnormal Level Of Lobbying"

A Senate committee is investigating Mentor, a giant for-profit foster care firm. Now, the firm has hired lobbyists who used to work for the leaders of the very committee conducting the investigation. The company has also hired a former White House lawyer famous for handling Congressional probes.

Posted on January 12, 2016, at 2:22 p.m.

 [Aram Roston](#)

RAISE YOUR VOICE

- **OKLAHOMA LEADS NATION IN ABUSE, NEGLECT BY FOSTER PARENTS THE CONFIRMED CASES OF ABUSE AND NEGLECT WERE 121 MORE THAN IN TEXAS, 34 MORE THAN IN CALIFORNIA - BY RANDY ELLIS THE OKLAHOMAN, FEB 12, 2017**
- **THE WHISTLEBLOWERS SAY THEY WITNESSED THESE ISSUES AND WERE FIRED FOR SPEAKING OUT ABOUT THEM. "AFTER 17 YEARS AT CHILD WELFARE, THEY FIRED ME BECAUSE I HAD AN OPINION," SAID HEIDI SINGLEY**
- **"THE THINGS THAT I SAW, I WOULD NEVER EVER PUT A CHILD IN SOME OF THOSE HOMES," SAID DAHN GREGG, A FORMER DEPARTMENT OF HUMAN SERVICES CASEWORKER.**
- **THE WHISTLEBLOWERS AND FAMILIES SAY THE CHILDREN ARE NOT GETTING THE CARE THEY NEED.**
- **NAACP TO FILE CLASS ACTION LAWSUIT AGAINST DHS OVER CHILD SAFETY ALLEGATIONS**

RAISE YOUR VOICE

- **THE PLAINTIFFS IN THE CASE ARE SEEKING MONETARY DAMAGES AND CHANGE IN THE SYSTEM, THEY SAY, NOT ONLY FAILS TO PROTECT CHILDREN BUT ALSO PUTS THEM IN HARM'S WAY.**
- **THE DHS CASEWORKERS WHO TOLD NEWS 9 IN A 2017 INVESTIGATION ABOUT HIGH CASELOADS AND THE DANGER THAT PUTS KIDS IN, WILL BE PART OF THE LAWSUIT. AS WILL DAHN GREGG WHO SPOKE TO NEWS 9 THE DAY SHE WAS FIRED AFTER SHE RAISED CONCERNS ABOUT DANGEROUS FOSTER HOMES. "AS WORKERS, THEY SHOULD BE ABLE TO GO AND SAY THIS IS A PROBLEM, AND SOMEONE SHOULD LISTEN TO THEM AND TAKE CARE OF IT," SAID GREGG.**
- **"UNLESS HE MAKES A SYSTEMIC CHANGE IN DHS FROM TOP TO BOTTOM A LAWSUIT CAN'T BE AVOIDED AT THIS POINT," SAID BUSSETT.**

RAISE YOUR VOICE

- **A STATE AUDIT QUESTIONS THE OKLAHOMA DEPARTMENT OF HUMAN SERVICES' USE OF \$10 MILLION IN FEDERAL FUNDS TO ASSIST NEEDY FAMILIES WITH ADOPTION EXPENSES. THE AUDIT SAYS DHS DIDN'T DETERMINE WHETHER THE FAMILIES QUALIFIED FOR THE TEMPORARY ASSISTANCE FOR NEEDY FAMILIES PROGRAM, CONSIDERING THEM "CHILD ONLY CASES."**
- **THE NATIONAL ASSOCIATION FOR THE ADVANCEMENT OF COLORED PEOPLE, FAMILIES AND FORMER EMPLOYEES ARE MOVING FORWARD WITH A CLASS ACTION LAWSUIT THAT WAS FILED AGAINST THE OKLAHOMA DEPARTMENT OF HUMAN SERVICES.**
- **THE FORMER EMPLOYEES ALSO ALLEGE DHS IS VIOLATING A PREVIOUS CLASS ACTION CIVIL RIGHTS LAWSUIT THE AGENCY SETTLED IN 2012, WHICH TARGETED ITS FOSTER CARE SYSTEM.**

Shawna is a worker for Child Protective Services. That's who's called in to investigate when DHS gets a report that children may be in danger. But she and two of her co-workers told News 9 that an unrealistic workload makes protecting those kids impossible. "Whenever workers who have left the agency or have been fired, they keep a case load for them so they can keep our numbers and make it look like we have less then we have," said Shawna.

"They're getting overworked, they're being asked to accomplish the impossible and kids are getting hurt," said Rachel Bussett an attorney who represents multiple DHS employees including these three women. "Workers are being disciplined when they don't close cases fast enough."

Shawna said she was also retaliated against when she brought these concerns to DHS Director Ed Lake in hopes of prompting change.

"We have cases that are a rolling backlog of 60 days and in some cases these children have never ever been seen and we're responsible as a worker if something were to happen," said Holly.

RAISE YOUR VOICE

➤ **THOSE CASELOADS OF 30 TO 40 CASES PER WORKER ARE A VIOLATION OF A CLASS ACTION SETTLEMENT CALLED THE “PINNACLE PLAN”, WHICH MANDATES ONLY 12 OPEN INVESTIGATIONS PER WORKER. THE MOST RECENT PINNACLE PLAN REPORT SHOWS 75 PERCENT OF INVESTIGATION CASELOADS ARE MEETING THOSE STANDARDS. BUT THESE LADIES TOLD NEWS 9 THAT'S NOT TRUE. IN ORDER TO REDUCE CASELOADS, THE WORKERS SAY THEY ARE MANDATED TO CLEAR CASES IN 30 TO 60 DAYS. THAT OFTEN RESULTS IN 60-HOUR WORK WEEKS AND SOMETIMES 20-HOUR DAYS.**

**“ WE HAVE FAMILY AFTER FAMILY
WITH THE SAME PROBLEM, AND YOU
CAN'T HAVE THE SAME PROBLEM ”
WITH DIFFERENT FAMILIES THAT
HAVE NO CONNECTION**

DANA BROCKWAY

DISCUSSION

CAN WE TALK ABOUT IT?



MUNICIPAL AUTHORITY AGENDA



The 6:00 PM meetings will be shown live on Channel 20 and streamed live on YouTube.



The recorded video will be available on YouTube and the City's website within 48 hours at www.youtube@midwestcityok.org.



The meeting minutes and video can be found on the City's website in the Agenda Center: <https://midwestcityok.org/AgendaCenter>.



To make a special assistance request, call 739-1215 or email pmenefee@midwestcityok.org no less than 24 hours prior to the start of a meeting. If special assistance is needed during a meeting, call 739-1388.



The Council will go directly into the City meetings down in the Council Chambers of City Hall at 6:00 PM. However, they will informally gather at or after 5:00 PM in the second floor conference room for dinner, but no City Council business will be discussed or acted upon and the room will be open to the public. Meals will only be provided to the City Council and staff.



MIDWEST CITY MUNICIPAL AUTHORITY AGENDA

City Hall - Midwest City Council Chambers, 100 N. Midwest Boulevard

May 14, 2019 - 6:01 PM

- A. CALL TO ORDER.
- B. CONSENT AGENDA. These items are placed on the Consent Agenda so that Trustees, by unanimous consent, can approve routine agenda items by one motion. If any item proposed does not meet with approval of all Trustees, or members of the audience wish to discuss an item, it will be removed and heard in regular order.
1. Discussion and consideration of approving the minutes of the regular meeting of April 23, 2019 as submitted. (City Clerk - S. Hancock)
 2. Discussion and consideration of supplemental budget adjustments to the following fund for FY 2018-2019, increase: Capital Improvement Revenue Bond Fund, revenue/Transfers In (00) \$224,971. Surplus Property Fund, expenses/Surplus Property (26) \$2,500. Water Fund, revenue/Transfers In (00) \$5,278. Capital Improvement Revenue Bond Fund, expenses /Transfers Out (00) \$224,971. Capital Improvement Revenue Bond Fund, revenue/Transfers In (00) \$135,403. Decrease: 2018 G.O. Bonds Municipal Authority Fund, expenses/John Conrad Regional Golf (47) \$81,125. (Finance - C. Barron)
 3. Discussion and consideration of awarding bid and entering into a contract with Midwest Wrecking in the amount of \$5,115.00 for the Demolition Services at 3200 N Air Depot Blvd., Midwest City, Oklahoma. (Public Works - R.P. Streets)
 4. Discussion and consideration of approving and entering into an agreement in the amount of \$12,000 with Dr. Irvin L. Wagner, Professor of Music at University of Oklahoma, for a 50-piece concert band to provide the headliner entertainment in Regional Park as part of the 2019 Tribute to Liberty 4th of July celebration. (Parks & Recreation - F. Gilles)
 5. Discussion and consideration of approving and entering into an agreement with Western Enterprises, Inc. in the amount of \$22,500 to provide a fireworks production for the 4th of July celebration (Tribute to Liberty) at Joe B. Barnes Regional Park on July 4, 2019. (Parks & Recreation - F. Gilles)
 6. Discussion and consideration of approving and entering into an agreement in the amount of \$6,000 with Production Essentials, LLC to provide a sound system and sound system services associated with entertainment in Regional Park as part of the 2019 Tribute to Liberty 4th of July celebration. (Parks & Recreation - F. Gilles)
 7. Discussion and consideration of declaring various items from Line Maintenance, Water Plant and Water Resource Recovery Facility surplus property and authorizing their disposal by sealed bid, public auction, or by other means as necessary. (Public Works - R.P. Streets)
 8. Discussion and consideration of declaring two pieces of equipment from the Sanitation Department surplus property and authorizing their disposal by sealed bid, public auction, or by other means as necessary. (Public Works - R.P. Streets)

- C. NEW BUSINESS/PUBLIC DISCUSSION. The purpose of the "Public Discussion Section" of the Agenda is for members of the public to speak to the Authority on any Subject not scheduled on the Regular Agenda. The Authority shall make no decision or take any action, except to direct the City Manager to take action, or to schedule the matter for discussion at a later date. Pursuant to the Oklahoma Open Meeting Act, the Authority will not engage in any discussion on the matter until that matter has been placed on an agenda for discussion. **THOSE ADDRESSING THE AUTHORITY ARE REQUESTED TO STATE THEIR NAME AND ADDRESS PRIOR TO SPEAKING TO THE AUTHORITY.**
- E. ADJOURNMENT.





CONSENT AGENDA



A notice for the regular Midwest City Municipal Authority was filed for the calendar year with the City Clerk of Midwest City. Public notice of this agenda was accessible at least 24 hours before this meeting at City Hall and on the Midwest City website (www.midwestcityok.org).

Midwest City Municipal Authority Minutes

April 23, 2019 – 6:01 PM

This meeting was held in the Midwest City Council Chamber in City Hall, 100 N. Midwest Boulevard, Midwest City, County of Oklahoma, State of Oklahoma.

Chairman Matt Dukes called the meeting to order at 7:00 PM with the following members present: Trustees Susan Eads, Pat Byrne, Española Bowen, Sean Reed, Christine Allen, and Jeff Moore; and Secretary Sara Hancock, City Attorney Heather Poole, and City Manager Guy Henson. Absent: none.

CONSENT AGENDA. Eads made a motion to approve the Consent Agenda, as submitted, seconded by Allen. Voting aye: Eads, Byrne, Bowen, Reed, Allen, Moore and Chairman Dukes. Nay: none. Absent: none. Motion carried.

1. Discussion and consideration to approve the minutes of the regular meeting of April 9, 2019, as submitted.
2. Discussion and consideration of accepting the report on the current financial condition of the Sheraton Midwest City Hotel at the Reed Center for the period ending March 31, 2019.
3. Discussion and consideration of the appointment of Tim Lyon as City Manager effective June 13, 2019, and acceptance of the terms of the proposed employment contract between the City of Midwest City and Tim Lyon.

NEW BUSINESS/PUBLIC DISCUSSION.

There was no new business or public discussion.

ADJOURNMENT.

There being no further business, Chairman Dukes closed the meeting at 7:01 PM.

ATTEST:

MATT DUKES, Chairman

SARA HANCOCK, Secretary



Finance Department

100 N. Midwest Boulevard
Midwest City, OK 73110
cbarron@midwestcity.org
Office: 405-739-1245
www.midwestcityok.org

TO: Honorable Chairman and Trustees
Midwest City Municipal Authority

FROM: Christy Barron, City Treasurer/Finance Director

DATE: May 14, 2019

SUBJECT: Discussion and consideration of supplemental budget adjustments to the following fund for FY 2018-2019, increase: Capital Improvement Revenue Bond Fund, revenue/Transfers In (00) \$224,971. Surplus Property Fund, expenses/Surplus Property (26) \$2,500. Water Fund, revenue/Transfers In (00) \$5,278. Capital Improvement Revenue Bond Fund, expenses/Transfers Out (00) \$224,971. Capital Improvement Revenue Bond Fund, revenue/Transfers In (00) \$135,403. Decrease: 2018 G.O. Bonds Municipal Authority Fund, expenses/John Conrad Regional Golf (47) \$81,125.

The first supplement is needed to increase transfer into Capital Improvement Revenue Bond Fund from General Fund due to sales tax revenue for fiscal year exceeding original estimate. The second supplement is needed to cover estimated utilities/communications expenses to end of fiscal year. The third supplement is needed to increase transfer into Water Fund from Customer Deposits Fund due to interest on customer utility deposits exceeding original fiscal year estimate. The fourth supplement is needed to increase transfers out of Capital Improvement Revenue Bond Fund to General Fund due to increase in sales tax revenue for fiscal year over original estimate. The fifth supplement is needed to increase transfer into Capital Improvement Revenue Bond Fund from Sales Tax Capital Improvements Fund due to sales tax revenue for fiscal year exceeding original estimate. The decrease is needed to reduce G.O. Bond Project budget due to revision of project management fee contract.

Christy Barron

Christy Barron
Finance Director

SUPPLEMENTS

May 14, 2019

Fund CAPITAL IMPROVEMENT REVENUE BOND (250)		BUDGET AMENDMENT FORM Fiscal Year 2018-2019			
		Estimated Revenue		Budget Appropriations	
<u>Dept Number</u>	<u>Department Name</u>	<u>Increase</u>	<u>Decrease</u>	<u>Increase</u>	<u>Decrease</u>
00	Transfers In	224,971			
		224,971	0	0	0
Explanation: To increase transfer in from General Fund due to sales tax revenue for fiscal year exceeding original estimate.					

Fund SURPLUS PROPERTY (081)		BUDGET AMENDMENT FORM Fiscal Year 2018-2019			
		Estimated Revenue		Budget Appropriations	
<u>Dept Number</u>	<u>Department Name</u>	<u>Increase</u>	<u>Decrease</u>	<u>Increase</u>	<u>Decrease</u>
26	Surplus Property			2,500	
		0	0	2,500	0
Explanation: To increase budget to cover estimated utilities/communications expenses to end of fiscal year. Funding to come from fund balance.					

Fund WATER (191)		BUDGET AMENDMENT FORM Fiscal Year 2018-2019			
		Estimated Revenue		Budget Appropriations	
<u>Dept Number</u>	<u>Department Name</u>	<u>Increase</u>	<u>Decrease</u>	<u>Increase</u>	<u>Decrease</u>
00	Transfers In	5,278			
		5,278	0	0	0
Explanation: To increase transfer in from Customer Deposits Fund due to interest on customer utility deposits exceeding original fiscal year estimate.					

Fund CAPITAL IMPROVEMENT REVENUE BOND (250)		BUDGET AMENDMENT FORM Fiscal Year 2018-2019			
		Estimated Revenue		Budget Appropriations	
<u>Dept Number</u>	<u>Department Name</u>	<u>Increase</u>	<u>Decrease</u>	<u>Increase</u>	<u>Decrease</u>
00	Transfers Out			224,971	
		0	0	224,971	0
Explanation: To increase budgeted transfers out to General Fund due to increase in sales tax revenue for fiscal year over original estimate. Funding to come from fund balance.					

SUPPLEMENTS

May 14, 2019

Fund CAPITAL IMPROVEMENT REVENUE BOND (250)		BUDGET AMENDMENT FORM Fiscal Year 2018-2019			
		Estimated Revenue		Budget Appropriations	
<u>Dept Number</u>	<u>Department Name</u>	<u>Increase</u>	<u>Decrease</u>	<u>Increase</u>	<u>Decrease</u>
00	Transfers In	135,403			
		135,403	0	0	0
Explanation:					
To increase transfer in from Sales Tax Capital Improvements Fund due to sales tax revenue for fiscal year exceeding original estimate.					

DECREASE

Fund 2018 G.O. BONDS MUNICIPAL AUTHORITY (271)		BUDGET AMENDMENT FORM Fiscal Year 2018-2019			
		Estimated Revenue		Budget Appropriations	
<u>Dept Number</u>	<u>Department Name</u>	<u>Increase</u>	<u>Decrease</u>	<u>Increase</u>	<u>Decrease</u>
47	JC Regional Golf				81,125
		0	0	0	81,125
Explanation:					
To decrease GO Bond Project budget due to revision of project management fee contract.					



Public Works Administration
Vaughn Sullivan, Director
vsullivan@midwestcityok.org
R. Paul Streets, Assistant Director
rstreets@midwestcityok.org
8730 S.E. 15th Street,
Midwest City, Oklahoma 73110
O: 405-739-1066 /Fax: 405-739-1090

Memorandum

To: Honorable Chairman and Trustees
Midwest City Municipal Authority

From: R. Paul Streets, Assistant Public Works Director

Date: May 14, 2019

Subject: Discussion and consideration of awarding the bid and entering into a contract with Midwest Wrecking in the amount of \$5,115.00 for the Demolition Services at 3200 N Air Depot Blvd., Midwest City, Oklahoma.

On Tuesday, April 23, 2019 at 2:00 p.m. the Midwest City Municipal Authority opened bids for demolition services at 3200 N Air Depot Blvd., Midwest City, Oklahoma. Bids were submitted by Midwest Wrecking and M & M Wrecking. Midwest Wrecking submitted the lowest and best bid in the amount of \$5,115.00. As such, we recommend awarding the bid and entering into a contract with Midwest Wrecking for demolition services at 3200 N Air Depot Blvd., Midwest City, Oklahoma.

This structure is located just west of the Water Resource Recovery Facility (WRRF), formerly known as the Waste Water Treatment Plant. The structure was included as part of a land acquisition, made necessary for a plant expansion project, in the early 1980s. Over the years, it has been used for a variety of municipal purposes; however, the structure is now in a state of disrepair and needs to be removed.

Funds for the demolition services are available in the WRRF Capital Outlay Account.

Staff recommends approval.

R. Paul Streets
Assistant Public Works Director

Attachment: Bid Tabulation Sheet

DEMOLITION SERVICES OF
3200 N AIR DEPOT BLVD
BID TAB

VENDOR

BID AMOUNT

Midwest Wrecking Co.
10200 N 1-35 Service Rd.
Oklahoma City, OK 73131
405-478-8833

\$ 5,115.00

M & M Wrecking
860 County Line Rd
Blanchard, OK 73010
405-392-4362

\$ 5,658.00

Total Demolition Services
16301 N Rockwell Ave.
Edmond, OK 73013
405-562-2994

\$ NO BID

Invitation for Sealed Bids

MIDWEST CITY MUNICIPAL AUTHORITY

100 N. MIDWEST BLVD.
MIDWEST CITY, OKLAHOMA 73110

Write legibly in ink or use typewriter.

Published In
Journal Record

Dates Advertised
Friday, April 5, 2019
Friday, April 12, 2019

Bids must be in the Office of the Secretary By:
Tuesday, April 23, 2019 no later than 2:00 p.m.

IMPORTANT: Bid envelope must indicate bid item enclosed and date of bid opening.

Description	Unit Price	Total Net Price
Demolition Services at 3200 N Air Depot Blvd., Midwest City, Oklahoma	\$ <u>5,115.00</u>	\$ <u>5,115.00</u>

THE MIDWEST CITY MUNICIPAL AUTHORITY IS EXEMPT FROM PAYMENT OF OKLAHOMA SALES TAX AND FEDERAL EXCISE TAX.

I have examined the specifications and agree, provided I am awarded a contract within thirty (30) days from the date fixed for opening bids, to provide the above described items for the sum shown, in accordance with the terms and conditions attached to this sheet as "Agreement By Bidder."

DEMOLITION WILL BE COMPLETED IN 15 DAYS OR LESS FROM DATE OF ORDER. DATED THIS _____ DAY OF _____, 2019.

FIRM Midwest Wrecking BY Chris Kates

ADDRESS P.O. Box 14668 OKC, OK 73113 TITLE V.P.

Accepted by the MIDWEST CITY MUNICIPAL AUTHORITY this _____ day of _____, 2019.

MATTHEW D. DUKES, II, Chairman

SARA HANCOCK, Secretary

Approved as to form this _____ day of _____, 2019.

HEATHER POOLE, City Attorney



Public Works Administration
Vaughn Sullivan, Director
vsullivan@midwestcityok.org
R. Paul Streets, Assistant Director
rstreets@midwestcityok.org
8730 S.E. 15th Street,
Midwest City, Oklahoma 73110
O: 405-739-1060 /Fax: 405-739-1090

Memorandum

TO: Honorable Chairman and Trustees, Midwest City Municipal Authority

FROM: Vaughn Sullivan, Public Works Director

DATE: May 14, 2019

SUBJECT: Discussion and consideration of approving and entering into an agreement in the amount of \$12,000 with Dr. Irvin L. Wagner, Professor of Music at University of Oklahoma, for a 50-piece concert band to provide the headliner entertainment in Regional Park as part of the 2019 Tribute to Liberty 4th of July celebration.

The Tribute to Liberty event will be similar to last year, with live music and an evening finale of fireworks choreographed to patriotic music. Staff has successfully negotiated an agreement again this year with Dr. Irvin L. Wagner, David Ross Boyd and Regents Professor of Music at University of Oklahoma, in the amount of \$12,000 for a 50-piece concert band to provide the evening's headliner entertainment. Last year was Dr. Wagner's sixth year to perform at the Tribute to Liberty event and his band's performance received great reviews from attendees of all ages.

Staff recommends approval.

Vaughn Sullivan
Public Works Director

Attachment: Dr. Irv Wagner Agreement



Public Works Administration
Vaughn Sullivan, Director
vsullivan@midwestcityok.org
R. Paul Streets, Assistant Director
rstreets@midwestcityok.org
8730 S.E. 15th Street,
Midwest City, Oklahoma 73110
O: 405-739-1060 /Fax: 405-739-1090

Tribute to Liberty Musical Entertainment Services Agreement

The Midwest City Municipal Authority (the "MCMA") would like to provide musical entertainment during the 2019 Tribute to Liberty where members of Dr. Irv Wagner's Concert Band (the "Band") will play a patriotically themed concert in a designated area of Joe B. Barnes Regional Park on Wednesday, July 4, 2019 from 8:30 p.m. until 9:45 p.m. The MCMA and the Band each agree to be responsible for the following tasks ensuring successful event execution:

The MCMA will:

1. Provide the location; and
2. Provide assistance with local publicity and public relations; and
3. Provide staging, sound and lighting; and
4. Provide electricity; and
5. Provide designated parking areas for Band members; and
6. Provide a tented area for Band members and equipment; and
7. Provide port-a-potties near tent area; and
8. Provide assistance in resolving other support issues that might arise; and
9. Provide compensation of \$12,000 to the Band.

The Band will:

1. Provide a concert band; and
2. Provide all musical instruments, chairs, music stands and stand lighting; and
3. Play patriotically themed music from 8:30 p.m. until 9:45 p.m. on July 4, 2019; and
4. Clean the area used when the event ends; and
5. Address and/or resolve other situations that might arise.

Matthew D. Dukes II, Chairman Date
MCMA

Dr. Irv Wagner Date
Dr. Irv Wagner's Concert Band

Attest:

Secretary

APPROVED as to form and legality this _____ day of _____, 2019.

City Attorney



Public Works Administration
Vaughn Sullivan, Director
vsullivan@midwestcityok.org
R. Paul Streets, Assistant Director
rstreets@midwestcityok.org
8730 S.E. 15th Street,
Midwest City, Oklahoma 73110
O: 405-739-1060 /Fax: 405-739-1090

Memorandum

TO: Honorable Chairman and Trustees, Midwest City Municipal Authority

FROM: Vaughn Sullivan, Public Works Director

DATE: May 14, 2019

SUBJECT: Discussion and consideration of approving and entering into an agreement with Western Enterprises, Inc. in the amount of \$22,500 to provide a fireworks production for the 4th of July celebration (Tribute to Liberty) at Joe B. Barnes Regional Park on July 4, 2019.

In observance of the 2019 July 4th holiday, the City of Midwest City wishes to once again provide a fireworks production located in Regional Park as part of the Tribute to Liberty event. In addition there will be live music and an evening finale of fireworks choreographed to patriotic music.

Western Enterprises provided an outstanding fireworks display during last year's Independence Day celebration at Joe B. Barnes Regional Park assisting staff in creating a festive atmosphere appealing to patrons of all ages.

Staff recommends approval.

Vaughn Sullivan
Public Works Director

Attachment: Western Enterprises Agreement

FIREWORKS PRODUCTION CONTRACT

1 of 2

1. This Contract is entered into this _____ day of _____, 20____, by and between **WESTERN ENTERPRISES, INC.**, designated herein as the "**SELLER**", and **THE MIDWEST CITY ECONOMIC DEVELOPMENT AUTHORITY AND THE MIDWEST CITY MUNICIPAL AUTHORITY**, designated herein as the "**PURCHASER**" for a fireworks production to be held on **JULY 4, 2019**.

2. **SELLER** will secure, prepare, **design, deliver and stage** said fireworks as outlined in "Attachment A", or will make necessary substitutions of equal or greater value. **SELLER** will include the services of a Pyrotechnic Operator to take charge of, set up and fire the display, along with such help as he deems necessary to perform the fireworks display safely, and in accordance with such Federal, State or Local laws that might be applicable.

3. **SELLER** agrees that the Operator and Assistant(s) are to check the display area after the presentation of the fireworks display for any "duds" or other material that might not have ignited. Any such material, found by any person other than the Operator, shall be returned to the Operator for safe handling or disposal of said material.

4. **PURCHASER** will furnish the secured minimum safety distances established by the **SELLER** after an on-site inspection of the proposed firing location. **PURCHASER** will provide adequate police protection and/or other adequate security to maintain these distances. **PURCHASER** also agrees to have a fire truck available on location during the display.

5. A Certificate of Insurance covering the fireworks display will be provided by the **SELLER** upon signing of the contract, for coverage in the amount of **FIVE MILLION DOLLARS (\$5,000,000.00)** broad form, bodily injury and property damage liability, Statutory Workers Compensation Coverage, Comprehensive Automobile Liability in the amount of **FIVE MILLION DOLLARS (\$5,000,000.00)** Combined Single Limit. **PURCHASER** agrees to provide a complete list of all additional insureds to be named on the certificate. Those entities/individuals listed on the certificate of insurance shall be deemed as additional insured per this contract.

6. It is agreed and understood that the **PURCHASER** will pay to the **SELLER** the sum of **TWENTY-TWO THOUSAND FIVE DOLLARS & NO/100 (\$22,500.00)** to be paid **within thirty (30) days after the date of the display**. **HOWEVER**, if payment is made in full by April 17, 2019, a five percent (5%) discount (**\$1,200.00**) will apply. That discount can either be deducted from the total contract price, or the **PURCHASER** may elect to receive that amount of extra pyrotechnic product in lieu of the discount. Unpaid accounts are subject to one percent (1%) interest charge per month after **thirty** days.

7. In the event of inclement weather or other adverse conditions, so as to cause postponement of the display it is agreed and understood that **PURCHASER** will notify **SELLER** regarding the postponement date, normally the following night, or at some future date within the calendar year. If the **PURCHASER** will not re-schedule the display within the calendar year, or completely cancels the display, **the PURCHASER agrees and understands that a 30% cancellation fee (\$6,750.00) of the full contract amount will apply. This amount will be deemed as full payment for cancellation of the display.** If the **PURCHASER** has exercised the "Early-Payment Option" for discount; the difference between the 30% cancellation fee and the early-payment amount will be refunded to the **PURCHASER**.

It is understood and agreed that **SELLER** shall be solely responsible for failure of the performance of the fireworks display for any reason under **SELLERS** control.

FIREWORKS PRODUCTION CONTRACT

2 of 2

8. Witness whereof, we have caused our signatures to be affixed to this Document, on this _____ day of _____, 20__.

WESTERN ENTERPRISES, INC.
SELLER

MIDWEST CITY
ECOMONIC DEVELOPMENT AUTHORITY
PURCHASER

BY: _____
Authorized agent

BY: _____
CHAIRMAN, Matthew D. Dukes II

MIDWEST CITY MUNICIPAL AUTHORITY
PURCHASER

BY: _____
CHAIRMAN, Matthew D. Dukes II

(SIG) _____
Notary Public

Notary Public in and for the State of Oklahoma

My Commission Expires: _____

My Commission #: _____

ATTEST:

SECRETARY, Sara Hancock

APPROVED as to form and legality this _____ day of _____, 2019.

AUTHORITY COUNSEL, Heather Poole



Public Works Administration
Vaughn Sullivan, Director
vsullivan@midwestcityok.org
R. Paul Streets, Assistant Director
rstreets@midwestcityok.org
8730 S.E. 15th Street,
Midwest City, Oklahoma 73110
O: 405-739-1060 /Fax: 405-739-1090

Memorandum

TO: Honorable Chair and Trustees

FROM: Vaughn Sullivan, Public Works Director

DATE: May 14, 2019

SUBJECT: Discussion and consideration of approving and entering into an agreement in the amount of \$6,000 with Production Essentials, LLC to provide a sound system and sound system services associated with entertainment in Regional Park as part of the 2019 Tribute to Liberty 4th of July celebration.

The Tribute to Liberty event will be similar to last year's event with Dr. Irvine Wagner's 50 piece concert band as headliner entertainment. Once again, the evening's grand finale will be fireworks choreographed to patriotic music. Staff has successfully negotiated an agreement with Production Essentials, LLC in the amount of \$6,000 for sound system rental and sound system services associated with the performance of the 50-piece concert band.

Staff recommends approval.

Vaughn Sullivan
Public Works Director

Attachment: Production Essentials Agreement



Public Works Administration
Vaughn Sullivan, Director
vsullivan@midwestcityok.org
R. Paul Streets, Assistant Director
rstreets@midwestcityok.org
8730 S.E. 15th Street,
Midwest City, Oklahoma 73110
O: 405-739-1060 /Fax: 405-739-1090

Tribute to Liberty Sound Services

Agreement

The Midwest City Municipal Authority (the "MCMA") would like to provide musical entertainment during the 2019 Tribute to Liberty where members of Production Essentials, LLC (the "Sound") will provide the sound services for musical entertainment in a designated area of Joe B. Barnes Regional Park on Wednesday, July 4, 2019 from 6:00 p.m. until 10:30 p.m. The MCMA and the Sound each agree to be responsible for the following tasks ensuring successful event execution:

The MCMA will:

1. Provide the location; and
2. Provide assistance with local publicity and public relations; and
3. Provide staging, sound and lighting; and
4. Provide electricity; and
5. Provide designated parking areas for Sound members; and
6. Provide a tented area for Sound members and equipment; and
7. Provide port-a-potties near tent area; and
8. Provide fireworks show soundtrack up to three days prior to show date of July 4, 2019; and
9. Provide assistance in resolving other support issues that might arise; and
10. Provide compensation of \$6,000 to Sound upon the completion of the event.

The Sound will:

1. Provide sound equipment including speakers and speaker towers, mics, mic stands, sound boards and sound staff; and
2. Provide proof of insurance; and
3. Provide concert related sound services for opening acoustic duo from 6:00 p.m. until 7:50 p.m. and headline 50 piece concert band from 8:30 p.m. until 9:45 p.m. on July 4, 2019; and
4. Provide sound services for fireworks show from 9:45 p.m. until 10:30 p.m.; and
5. Clean the area used when the event ends; and
6. Address and/or resolve other situations that might arise.

Matthew D. Dukes II, Chairman Date
MCMA

David Brecheen Date
Production Essentials, LLC

Attest:

Secretary

APPROVED as to form and legality this _____ day of _____, 2019.

Authority Counsel



Public Works Administration
Vaughn Sullivan, Director
vsullivan@midwestcityok.org
R. Paul Streets, Assistant Director
rstreets@midwestcityok.org

8730 S.E. 15th Street,
Midwest City, Oklahoma 73110
O: 405-739-1060 /Fax: 405-739-1090

Memo

To: Honorable Chairman and Trustees
Midwest City Municipal Authority

From: R. Paul Streets, Assistant Public Works Director

Date: May 14, 2019

Subject: Discussion and consideration of declaring various items from Line Maintenance, Water Plant and Water Resource Recovery Facility surplus property and authorizing their disposal by sealed bid, public auction, or by other means as necessary.

The various items listed below has been or will be removed from service and have no other operational value or applications. Recommend declaring these various items surplus property and authorizing their disposal by sealed bid, public auction or by other means as necessary.

Line Maintenance:

- (63) Sixty-Three fluorescent light fixtures
- (1) One 30"x 36" locking wood cabinet with (3) shelves
- (1) One Dwyer kitchenette
- (1) One Peerless 150,000 BTU natural gas space heater without blower motor, Model #UH150A
- (1) One 48" tan file cabinet
- (1) One computer desk with shelves
- (1) One 30" Sony Trinitron TV, Model # KV32FS120
- (1) One Magnavox VHS VCR, model # VR9510AT01
- (1) One Mitsubishi VHS VCR, model # HS-U20
- (1) One 42" black Bretford TV stand with (2) doors
- (1) One toilet seat with bowl
- (1) One particle board computer office desk with shelves
- (1) One box of random sized nuts and bolts
- (1) One 55 gallon green drum of random sized nuts and bolts
- (1) One RCA Camcorder with plastic carry case with (1) battery charger, (1) rechargeable battery, model # DSP3
- (1) One Honda dewatering trash pump disassembled and does not run
- (1) One Honda generator 5.5hp
- (1) One Husky generator with Honda Engine, 4550 starting watts,3650 running watts, does not run

- (1) One Stihl chainsaw, model # 025, no chain, does not run
- (1) One Stihl chainsaw, model # M5250, disassembled
- (1) One Makita chop saw, does not run
- (1) One HP printer Model 5550

Water Plant:

- (12) Twelve Symax Racks and miscellaneous parts for the SCADA system
- (1) One 2003 John Deere GX345 riding mower equipment # 42-04-02 (no longer works)
- (1) One Radio Tower and associated antennas, wiring and equipment (no longer works)
- (1) One 3000 Ft. of 2 gauge wire cut and stripped
- (1) One 7.5 HP Yeoman sludge pump serial # 9801991-B
- (1) One Liftmaster 1hp gate operator serial # unreadable
- (1) One Roots rotary lobe air blower serial # 8465836
- (1) One Tuttnauer 2540E autoclave serial # 18010459
- (1) One GE TOC analyzer serial # 1009-4268
- (1) One Hach turbidimeter serial # 950400000515
- (1) One Ouebec model 3330 colony counter no serial number
- (9) Nine wood framed cushioned chairs
- (1) One U-shaped desk City of MWC # 1380
- (1) One 20hp motor and pump serial # R6FM20T-C39330
- (2) Two 10hp Magniteck hydraulic pump motors no serial number
- (1) One Electric motor serial # E817A-T03T008R023F
- (9) Nine Hach 1720C turbidimeters serial #'s 950800011373, 960400014110, 950800011378, 950800011380, 950800011377, 950800011382, 950800011379 and (2) Two without serial numbers.

Water Resource Recovery Facility:

- (1) One Thermo Barnstead water purification model #D11931 Serial #1370090217595
- (1) One Thermo centrifuge model #8456 serial #84640350
- (1) One Corning hot plate model #6795-410D serial #023407138201
- (1) One Precision hot water bath model #182 serial #604011665
- (1) One Thermo incubator model #TFFU2065FWA serial #WB12459307
- (1) One Label Shop label maker model #Labelshop serial #2010M
- (1) One HP printer cartridge 80X Black
- (1) One Hanna portable digital thermometer model #HI 9060
- (1) One Labconco TKN micro distillation unit glassware, no electrical
- (1) One GE vacuum pump model #5KH32REG 550AS serial #0774
- (1) One GE vacumm pump model #0211-145N-G8CX serial #0885
- (1) One Campbell Hausfeld portable air compressor has 2 serial numbers on this item serial # L6/7/1999-00367 & serial # VT470000KB

Staff recommends approval.



R. Paul Streets
Assistant Public Works Director



Public Works Administration
Vaughn Sullivan, Director
vsullivan@midwestcityok.org
R. Paul Streets, Assistant Director
rstreets@midwestcityok.org

8730 S.E. 15th Street,
Midwest City, Oklahoma 73110
O: 405-739-1060 /Fax: 405-739-1090

Memo

To: Honorable Chairman and Trustees
Midwest City Municipal Authority

From: **R. Paul Streets, Assistant Public Works Director**

Date: May 14, 2019

Subject: Discussion and consideration of declaring two pieces of equipment, unit #41-03-23 and #41-03-24, from the Sanitation Department surplus property and authorizing their disposal by sealed bid, public auction, or by other means as necessary.

The equipment listed below has or will be removed from service when a replacement arrives and have no other operational value or applications. As such, and in accordance with guidelines set forth in two separate Association of Central Oklahoma Governments (ACOG) grant applications, we recommend declaring both of these items surplus property and authorizing their disposal by sealed bid, public auction or by other means as necessary.

1. Unit # 41-03-23 VIN# 3BPZH58XXAF108304, A 2010 Heil Automated Side Loading (ASL) body mounted on a 2010 single-axle Peterbilt truck chassis estimated value of under \$9,999.00. *This unit will remain in service until we receive the new equipment ordered as a part of the ACOG grant.*
2. Unit # 41-03-24 VIN# 3BPZH58XXAF108305, A 2010 Bridgeport ASL body mounted on a 2010 single-axle Peterbilt truck chassis estimated value of under \$9,999.00.

Staff recommends approval.

R. Paul Streets
Assistant Public Works Director



NEW BUSINESS/
PUBLIC DISCUSSION





MEMORIAL HOSPITAL AUTHORITY AGENDA



The 6:00 PM meetings will be shown live on Channel 20 and streamed live on YouTube.



The recorded video will be available on YouTube and the City's website within 48 hours at www.youtube@midwestcityok.org.



The meeting minutes and video can be found on the City's website in the Agenda Center: <https://midwestcityok.org/AgendaCenter>.



To make a special assistance request, call 739-1215 or email pmenefee@midwestcityok.org no less than 24 hours prior to the start of a meeting. If special assistance is needed during a meeting, call 739-1388.



The Council will go directly into the City meetings down in the Council Chambers of City Hall at 6:00 PM. However, they will informally gather at or after 5:00 PM in the second floor conference room for dinner, but no City Council business will be discussed or acted upon and the room will be open to the public. Meals will only be provided to the City Council and staff.



MIDWEST CITY MEMORIAL HOSPITAL AUTHORITY AGENDA

City Hall - Midwest City Council Chambers, 100 N. Midwest Boulevard

May 14, 2019 - 6:02 PM

- A. CALL TO ORDER.
- B. CONSENT AGENDA. These items are placed on the Consent Agenda so that the Trustees, by unanimous consent, can approve routine agenda items by one motion. If any item proposed does not meet with approval of all Trustees, or members of the audience wish to discuss an item, it will be removed and heard in regular order.
1. Discussion and consideration of approving the minutes of the regular meeting of April 23, 2019, as submitted. (City Clerk - S. Hancock)
 2. Discussion and consideration of supplemental budget adjustments to the following fund for FY 2018-2019, increase: Hospital Authority Fund, revenue/Transfers In (90) \$39,679; revenue /Investment Interest (90) \$54; expenses/Transfers Out (90) \$39,679. Hospital Authority Fund, expenses/Hospital Authority (90) \$6,308. (Finance - C. Barron)
- C. DISCUSSION ITEM.
1. Discussion and consideration of accepting the Hospital Authority Investment Performance Review for the period ending March 31, 2019 and action to reallocate assets, change fund managers or make changes in the Statement of Investment Policy, Guidelines and Objectives. (City Manager - G. Henson)
- D. NEW BUSINESS/PUBLIC DISCUSSION. The purpose of the "Public Discussion Section" of the Agenda is for members of the public to speak to the Authority on any Subject not scheduled on the Regular Agenda. The Authority shall make no decision or take any action, except to direct the City Manager to take action, or to schedule the matter for discussion at a later date. Pursuant to the Oklahoma Open Meeting Act, the Authority will not engage in any discussion on the matter until that matter has been placed on an agenda for discussion. **THOSE ADDRESSING THE AUTHORITY ARE REQUESTED TO STATE THEIR NAME AND ADDRESS PRIOR TO SPEAKING TO THE AUTHORITY.**
- E. ADJOURNMENT.



CONSENT AGENDA



A notice for the regular Midwest City Memorial Hospital Authority was filed for the calendar year with the City Clerk of Midwest City. Public notice of this agenda was accessible at least 24 hours before this meeting at City Hall and on the Midwest City website (www.midwestcityok.org).

Midwest City Memorial Hospital Authority Minutes

April 23, 2019 – 6:02 pm

This meeting was held in the Midwest City Council Chambers at City Hall, 100 North Midwest Boulevard, Midwest City, County of Oklahoma, State of Oklahoma.

Chairman Matt Dukes called the meeting to order at 7:02 PM with the following members present: Trustees: Susan Eads, Pat Byrne, Española Bowen, Sean Reed, Christine Allen, and Jeff Moore; and Secretary Sara Hancock, City Attorney Heather Poole, and City Manager Guy Henson. Absent: none.

CONSENT AGENDA. Allen made a motion to approve the Consent Agenda, as submitted, seconded by Eads. Voting aye: Eads, Byrne, Bowen, Reed, Allen, Moore and Chairman Dukes. Nay: none. Absent: none. Motion carried.

1. Discussion and consideration to approve the minutes of the regular meeting of April 9, 2019, as submitted.
2. Discussion and consideration of renewing the Lease Agreement with Independent School District No. 52 of Oklahoma County, Oklahoma to lease the ArtzPlace building, located at 1730 Center Drive, for \$5,168 per month for fiscal year 2019-20.
3. Discussion and consideration of the appointment of Tim Lyon as City Manager effective June 13, 2019, and acceptance of the terms of the proposed employment contract between the City of Midwest City and Tim Lyon.

DISCUSSION ITEM.

1. **Discussion and consideration of action to reallocate assets, change fund managers or make changes in the Statement of Investment Policy, Guidelines and Objectives.** No action taken.

NEW BUSINESS/PUBLIC DISCUSSION.

There was no new business or public discussion.

ADJOURNMENT.

There being no further business, Chairman Dukes adjourned the meeting at 7:03 PM.

ATTEST:

MATT DUKES, Chairman

SARA HANCOCK, Secretary



Midwest City Memorial Hospital Authority

100 North Midwest Boulevard
Midwest City, Oklahoma 73110
(405) 739-1207 Fax (405) 739-1208 TDD (405) 739-1359
E-mail: ghenson@midwestcityok.org

MEMORANDUM

TO: Honorable Chairman and Trustees

FROM: Christy Barron, Treasurer/Finance Director

DATE: May 14, 2019

SUBJECT: Discussion and consideration of supplemental budget adjustments to the following fund for FY 2018-2019, increase: Hospital Authority Fund, revenue/Transfers In (90) \$39,679; revenue/Investment Interest (90) \$54; expenses/Transfers Out (90) \$39,679. Hospital Authority Fund, expenses/Hospital Authority (90) \$6,308.

The first supplement is needed to increase budget for interest revenue and intrafund transfer due to 2% compounded principal and loan reserve interest exceeding original fiscal year estimates. The second supplement is needed to cover contractual expenses to end of fiscal year.

Christy Barron

Christy Barron
Finance Director

SUPPLEMENTS

May 14, 2019

Fund HOSPITAL AUTHORITY (425)		BUDGET AMENDMENT FORM Fiscal Year 2018-2019			
		Estimated Revenue		Budget Appropriations	
<u>Dept Number</u>	<u>Department Name</u>	<u>Increase</u>	<u>Decrease</u>	<u>Increase</u>	<u>Decrease</u>
90	Transfers In	39,679			
90	Investment Interest	54			
90	Transfers Out			39,679	
		39,733	0	39,679	0
		39,733	0	39,679	0

Explanation:
Increase budget for intrafund transfers due to 2% compounded principal (\$39,625) and loan reserve interest (\$54) exceeding original fiscal year estimates.

Fund HOSPITAL AUTHORITY (425)		BUDGET AMENDMENT FORM Fiscal Year 2018-2019			
		Estimated Revenue		Budget Appropriations	
<u>Dept Number</u>	<u>Department Name</u>	<u>Increase</u>	<u>Decrease</u>	<u>Increase</u>	<u>Decrease</u>
90	Hospital Authority			6,308	
		0	0	6,308	0
		0	0	6,308	0

Explanation:
Increase budget to cover contractual expenses to end of fiscal year. Funding to come from fund balance.



DISCUSSION ITEM





Midwest City Memorial Hospital Authority
100 North Midwest Boulevard
Midwest City, Oklahoma 73110
Office (405) 739-1207/Fax (405) 739-1208
www.midwestcityok.org

MEMORANDUM

To: Honorable Chairman and Trustees

From: Sara Hancock, Secretary

Date: May 14, 2019

Subject: Discussion and consideration of accepting the Hospital Authority Investment Performance Review for the period ending March 31, 2019 and action to reallocate assets, change fund managers or make changes in the Statement of Investment Policy, Guidelines and Objectives.

Jim Garrels, President, Fiduciary Capital Advisors, will be present at the meeting to present the Performance Review. Any need to reallocate assets, change fund managers or make changes to the Investment Policy Guidelines and Objectives will be addressed at the meeting.

Action is at the discretion of the Authority.

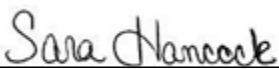
Sara Hancock, Secretary

**MIDWEST CITY
MEMORIAL HOSPITAL AUTHORITY
INVESTMENT PERFORMANCE REVIEW
PERIODS ENDING
MARCH 31, 2019**

**MIDWEST CITY MEMORIAL HOSPITAL AUTHORITY
COMPOSITE VS. POLICY PORTFOLIO
PERIODS ENDING 3-31-19**

	QTR		YTD		1 Year		3 Years	
	Return	Rank	Return	Rank	Return	Rank	Return	Rank
Total Fund Composite	10.39	49	10.39	49	6.75	35	10.79	27
Policy Portfolio*	10.21	52	10.21	52	7.85	24	9.69	41

	5 Years		10 Years		From 12-31-96		From 9-30-96	
	Return	Rank	Return	Rank	Return	Rank	Return	Rank
Total Fund Composite	7.88	19	11.47	48	7.56	23	7.69	23
Policy Portfolio*	7.13	30	11.22	54	7.06	36	7.26	34

* 75% S&P 500, 10% BARCLAYS CAPITAL AGG, 15% 90-day U.S. T-bill

This report is based on information we believe to be reliable but can in no way guarantee as to its accuracy or completeness. Past performance is no guarantee of future results.

**MIDWEST CITY MEMORIAL HOSPITAL AUTHORITY
RETURN SUMMARY
PERCENTILE RANKS
PERIODS ENDING 3-31-19**

	QTR		YTD		1 Year		3 Years		5 Years		10 Years		From 12-31-96	
	Return	Rank	Return	Rank	Return	Rank	Return	Rank	Return	Rank	Return	Rank	Return	Rank
Vs. 100% Equity Universe														
Total Equity	13.99	47	13.99	47	8.22	35	14.25	25	10.95	17	15.59	38	7.87	63
Active - Equity	14.50	40	14.50	40	6.33	47	15.54	18	10.99	16	15.17	48	7.30	78
Passive - Equity	13.66	51	13.66	51	9.54	25	13.50	30	10.92	17	15.91	30	8.22	50
S&P 500	13.65	51	13.65	51	9.50	25	13.51	30	10.91	17	15.92	29	8.23	50
Vs. 100% Fixed Income Universe														
Total Fixed Income	2.99	48	2.99	48	4.52	21	1.93	68	2.69	46	3.55	63	5.03	34
Passive - Fixed	2.99	48	2.99	48	4.58	20	2.11	63	2.84	41	3.91	59	5.04	33
BBC Aggregate	2.94	50	2.94	50	4.48	22	2.03	65	2.74	44	3.77	60	5.04	33
BBC G/C	3.26	42	3.26	42	4.48	22	2.12	63	2.78	43	3.92	59	5.09	31
90 Day US T-Bill	0.60	98	0.60	98	2.11	88	1.17	89	0.72	96	0.41	99	2.12	99
Total Cash	0.59	--	0.59	--	2.08	--	*1.75	(6/30/17)						
BlackRock Shrt Tm Inv Fnd	0.66	--	0.66	--	2.38	--	*2.00	(6/30/17)						
Federated MMF	0.55	--	0.55	--	1.94	--	*1.54	(6/30/17)						
90 Day US T-Bill	0.60	--	0.60	--	2.11	--	*1.72	(6/30/17)						
Average U.S. MMF (Morningstar)	0.46	--	0.46	--	1.58	--	*1.33	(6/30/17)						

**MIDWEST CITY MEMORIAL HOSPITAL AUTHORITY
RETURN SUMMARY
PERIODS ENDING 3-31-19**

	QTR		YTD		1 Year		3 Years		5 Years		10 Years		Fr 12-31-96	
	Return	Rank	Return	Rank	Return	Rank	Return	Rank	Return	Rank	Return	Rank	Return	Rank
Vs. 100% Equity Universe														
Growth Funds														
Harbor Capital Appreciation	17.54	15	17.54	15	11.52	16	18.49	7	13.94	3	*16.82	*3	(12/31/12)	--
T. Rowe Price New America	15.76	28	15.76	28	12.28	13	18.88	6	13.97	3	*16.70	*4	(12/31/12)	--
S&P 500	13.65	51	13.65	51	9.50	25	13.51	30	10.91	17	*13.96	*20	(12/31/12)	--
Vs. 100% Equity Universe														
Vanguard Mid Cap Growth	20.74	5	20.74	5	12.22	13	13.71	29	9.38	33	15.98	28	*9.57	*17 (12/03)
S&P 500	13.65	51	13.65	51	9.50	25	13.51	30	10.91	17	15.92	29	*8.54	*41 (12/03)
PrimeCap Odyssey Agg. Growth	14.36	42	14.36	42	-4.57	95	17.96	9	13.09	6	*19.22	*1	(12/31/12)	--
S&P 500	13.65	51	13.65	51	9.50	25	13.51	30	10.91	17	*13.96	*20	(12/31/12)	--
Vs. 100% Equity Universe														
Value Funds														
Dodge & Cox Stock	10.29	92	10.29	92	4.31	58	14.10	26	8.65	43	*15.55	*18	(9/30/11)	--
S&P 500	13.65	51	13.65	51	9.50	25	13.51	30	10.91	17	*15.43	*19	(9/30/11)	--
Vanguard Equity Income	11.11	85	11.11	85	7.58	39	11.26	55	9.38	33	*12.49	*41	(12/31/12)	--
S&P 500	13.65	51	13.65	51	9.50	25	13.51	30	10.91	17	*13.96	*20	(12/31/12)	--

MIDWEST CITY MEMORIAL HOSPITAL AUTHORITY
RETURN SUMMARY
PERIODS ENDING 3-31-19
UNIVERSES BETA ADJUSTED

	QTR		YTD		1 Year		3 Year		5 Year		10 Year		From 12-31-03	
	Return	Rank	Return	Rank	Return	Rank	Return	Rank	Return	Rank	Return	Rank	Return	Rank
Vs. 100% Large Cap Growth Universe (Hi-Beta)														
Harbor Capital Appreciation	17.54	56	17.54	56	11.52	46	18.49	28	13.94	17	*16.82	*14	(12/31/12)	--
Russell 1000 Growth	16.10	81	16.10	81	12.75	29	16.53	45	13.50	22	*16.11	*23	(12/31/12)	--
Average Large Cap Growth	15.98	83	15.98	83	10.81	56	14.90	69	10.82	28	*13.93	*66	(12/31/12)	--
Vs. 100% Large Cap Growth Universe (Mid-Beta)														
T. Rowe Price New America	15.76	54	15.76	54	12.28	30	18.88	6	13.97	11	*16.70	*9	(12/31/12)	--
Russell 1000 Growth	16.10	42	16.10	42	12.75	24	16.53	27	13.50	16	*16.11	*18	(12/31/12)	--
Average Large Cap Growth	15.98	45	15.98	45	10.81	51	14.90	52	10.82	61	*13.93	*61	(12/31/12)	--
Vs. 100% Mid Cap Growth Universe (Mid-Beta)														
Vanguard Mid Cap Growth	20.74	3	20.74	3	12.22	11	13.71	61	9.38	35	15.98	61	*9.57	*37 (12/03)
Russell Mid Growth	19.62	23	19.62	23	11.51	13	15.06	51	10.89	17	17.60	15	*10.11	*23 (12/03)
Average Mid Cap Growth	17.33	36	17.33	36	8.28	38	15.55	46	8.84	52	16.26	52	*9.33	*51 (12/03)
Vs. 100% Mid Cap Growth Universe (Hi-Beta)														
PrimeCap Odyssey Agg. Growth	14.36	99	14.36	99	-4.57	99	17.96	55	13.09	6	*19.22	*1	(12/31/12)	--
Russell Mid Growth	19.62	55	19.62	55	11.51	39	15.06	73	10.89	22	*14.44	*35	(12/31/12)	--
Average Mid Cap Growth	17.33	82	17.33	82	8.28	73	15.55	71	8.84	55	*12.93	*65	(12/31/12)	--
Vs. 100% Large Cap Value Universe (Hi-Beta)														
Dodge & Cox Stock	10.29	96	10.29	96	4.31	29	14.10	5	8.65	24	*15.55	*6	(9/30/11)	--
Russell 1000 Value	11.93	75	11.93	75	5.67	19	10.45	60	7.72	46	*13.77	*42	(9/30/11)	--
Average Large Cap Value	12.19	72	12.19	72	4.31	29	10.55	58	7.55	48	*13.12	*60	(9/30/11)	--
Vs. 100% Large Cap Value Universe (Lo-Beta)														
Vanguard Equity Income	11.11	40	11.11	40	7.58	36	11.26	24	9.38	11	*12.49	*16	(12/31/12)	--
Russell 1000 Value	11.93	26	11.93	26	5.67	52	10.45	40	7.72	48	*11.56	*37	(12/31/12)	--
Average Large Cap Value	12.19	19	12.19	19	4.31	67	10.55	37	7.55	55	*11.34	*44	(12/31/12)	--

**MIDWEST CITY MEMORIAL HOSPITAL AUTHORITY
PERIODS ENDING 3-31-19**

MIDWEST CITY COMPOSITE VS. POLICY PORTFOLIO

	1 Year	3 Years	5 Years	10 Years	From 9-30-96
Alpha	-0.25	0.27	0.19	0.07	0.10
Beta	1.03	1.03	1.04	1.03	1.00
R - squared	1.00	0.99	0.99	0.99	0.98
STD for Composite	15.41	9.37	8.66	10.88	11.78
STD for Policy Portfolio*	14.96	9.08	8.32	10.53	11.65

* 75% S&P 500, 10% BARCLAYS CAPITAL AGG, 15% 90-day U.S. T-bill

MIDWEST CITY COMPOSITE VS. S&P 500

	1 Year	3 Years	5 Years	10 Years	From 9-30-96
Alpha	-0.89	-0.72	-0.79	-1.13	-0.38
Beta	0.76	0.76	0.79	0.78	0.70
R - squared	1.00	0.98	0.97	0.97	0.96
STD for Composite	15.41	9.37	8.66	10.88	11.78
STD for S&P 500	20.21	12.21	10.77	13.67	16.44

**MIDWEST CITY MEMORIAL HOSPITAL AUTHORITY
ASSET ALLOCATION
PERIOD ENDED 3-31-19**

	Domestic Equity	Foreign Equity	US Bond	Cash	Total	Percent of Total	Target	Range
Blackrock Equity Index	45,028,398				45,028,398	44.8%		
Harbor Capital Appreciation	4,873,868				4,873,868	4.8%		
T. Rowe Price New America Gr.	4,194,039				4,194,039	4.2%		
Primecap Odyssey Agg Growth	5,321,753				5,321,753	5.3%		
Vanguard Mid Growth	4,032,255				4,032,255	4.0%		
Dodge & Cox Stock	5,805,923				5,805,923	5.8%		
Vanguard Equity Income	4,955,871				4,955,871	4.9%		
TOTAL US EQUITY	74,212,106				74,212,106	73.8%	70.0%	20.0 - 85.0%
Blackrock US Debt Index			8,832,318		8,832,318	8.8%		
TOTAL US BOND			8,832,318		8,832,318	8.8%	30.0%	2.5 - 80.0%
Black Rock STIF				4,621,463	4,621,463	4.6%		
Federated Cash				12,865,111	12,865,111	12.8%		
TOTAL CASH				17,486,575	17,486,575	17.4%	0.0%	0.0 - 20.0%
TOTAL	74,212,106 73.8%	0 0.0%	8,832,318 8.8%	17,486,575 17.4%	100,530,999 100.0%		100.0%	

**MIDWEST CITY MEMORIAL HOSPITAL AUTHORITY
PERIOD ENDED 3-31-19**

ALLOCATION CHANGE			
	December 31, 2018	March 31, 2019	Change
Domestic Equity	65,105,513	74,212,106	9,106,593
Domestic Bond	8,575,781	8,832,318	256,537
Cash	17,393,983	17,486,575	92,592
TOTAL FUND	91,075,277	100,530,999	9,455,722

ACTUAL vs. POLICY PORTFOLIO			
	Actual Allocation	Policy Allocation	Allocation Range
Domestic Equity	73.8%	70.0%	20 - 85%
Domestic Bond	8.8%	30.0%	2.5 - 80%
Cash	17.4%	0.0%	0 - 20%

**MIDWEST CITY MEMORIAL HOSPITAL AUTHORITY
ASSET ALLOCATION
PERIOD ENDED 3-31-19**

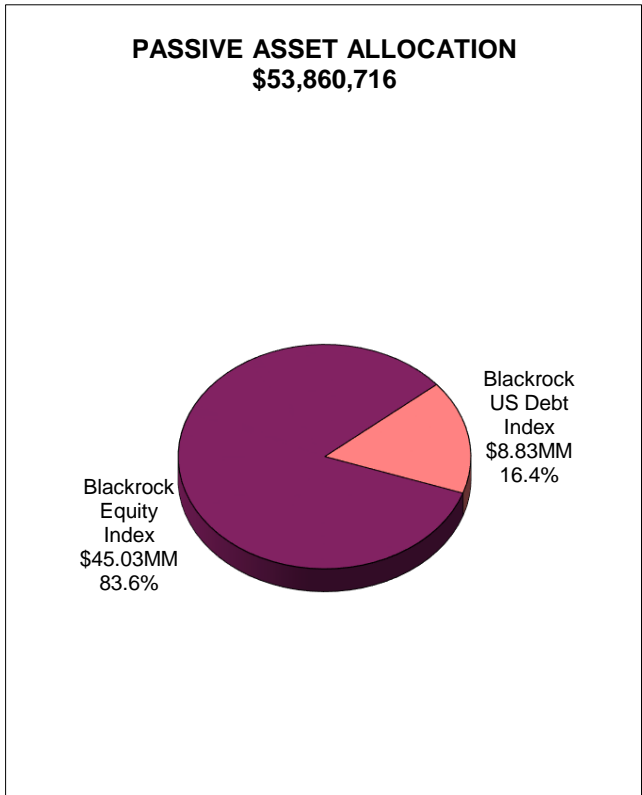
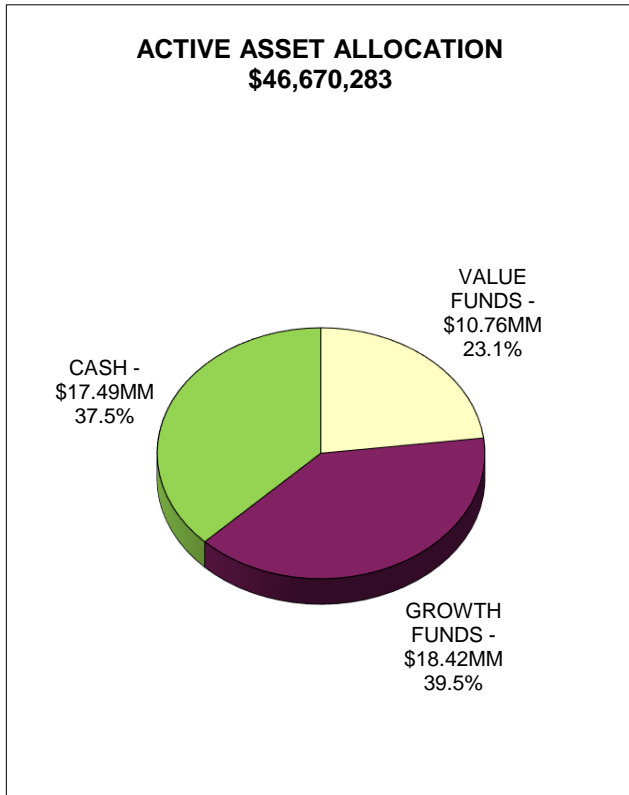
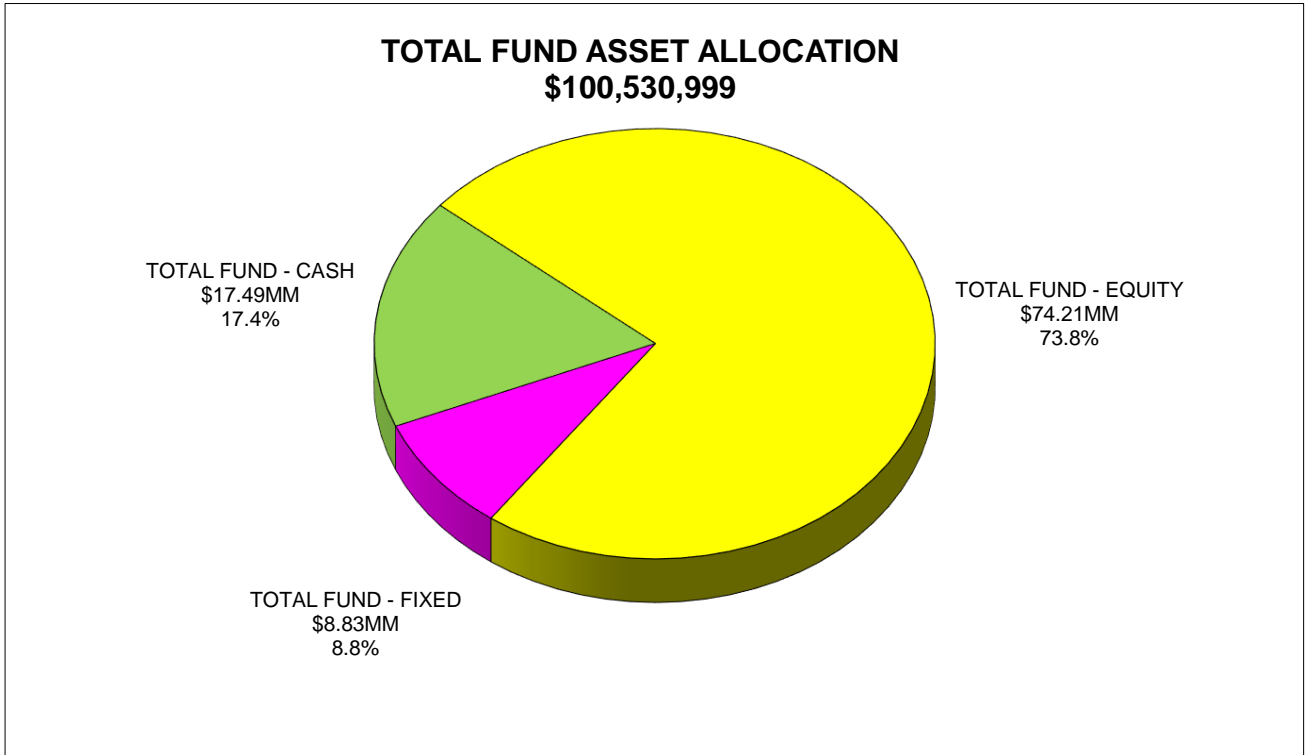

**MIDWEST CITY MEMORIAL HOSPITAL AUTHORITY
PERIOD ENDED 3-31-19**

**LARGE GROWTH FUNDS COMPOSITE ASSET ALLOCATION
\$9,067,907**

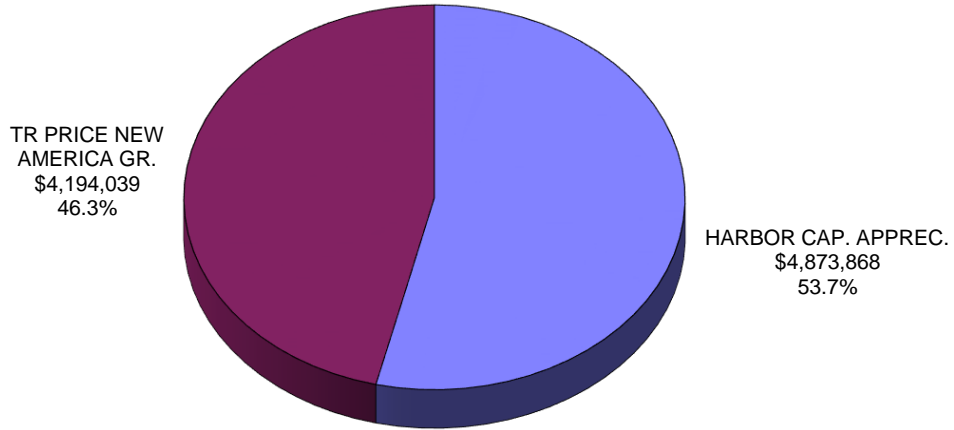

LARGE GROWTH EQUITY CHARACTERISTICS v. S&P 500

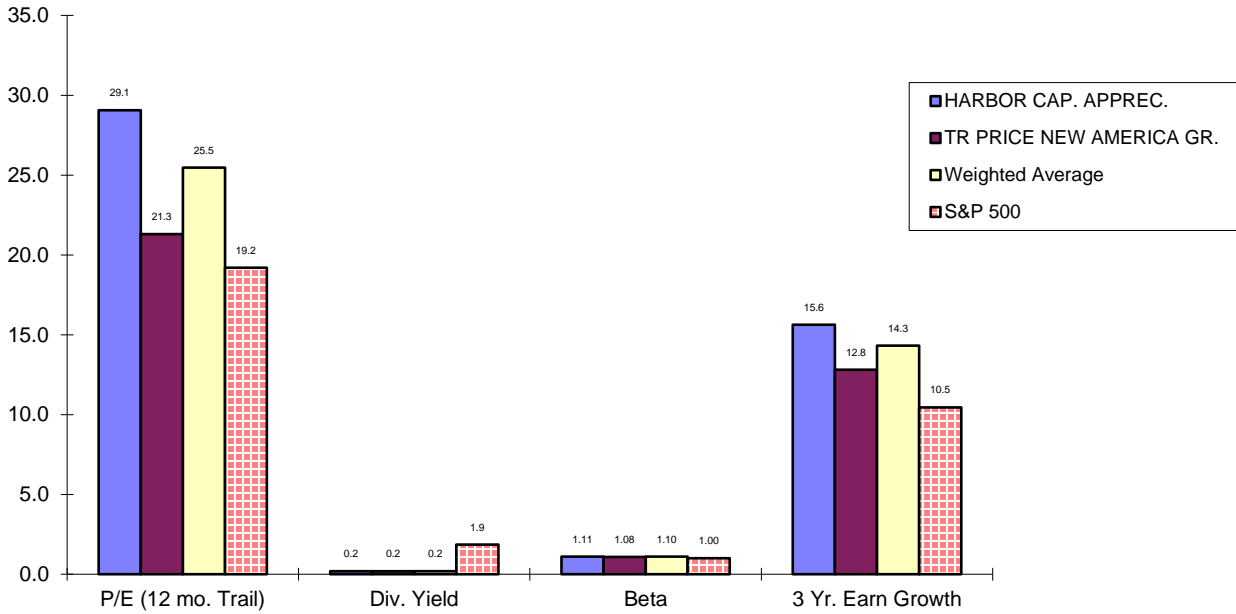

**MIDWEST CITY MEMORIAL HOSPITAL AUTHORITY
PERIODS ENDED 3-31-19**

**MID GROWTH FUNDS COMPOSITE ASSET ALLOCATION
\$9,354,007**

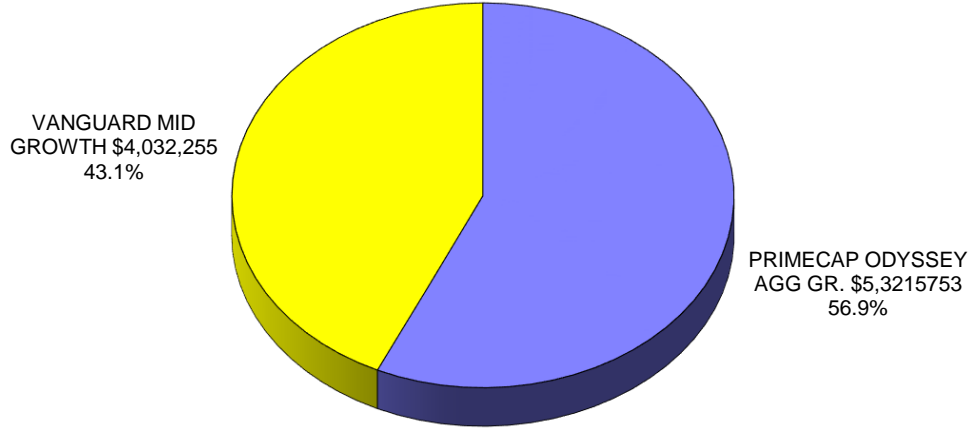

MID GROWTH EQUITY CHARACTERISTICS v. S&P 500

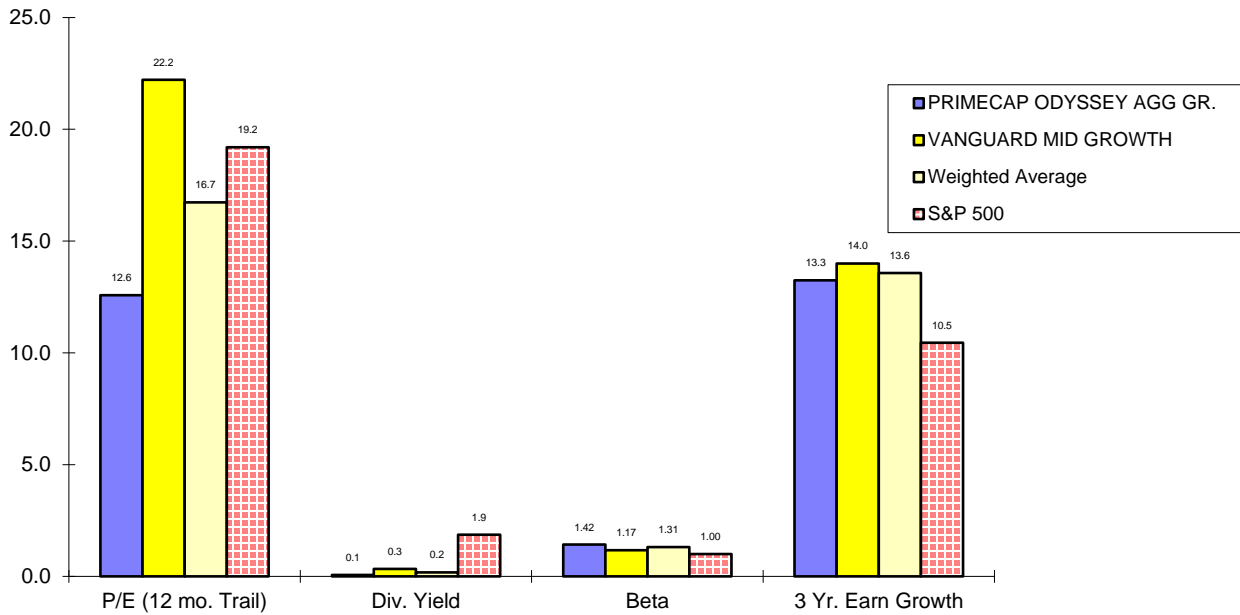

MIDWEST CITY MEMORIAL HOSPITAL AUTHORITY
PERIOD ENDED 3-31-19

VALUE FUNDS COMPOSITE ASSET ALLOCATION
\$10,761,794

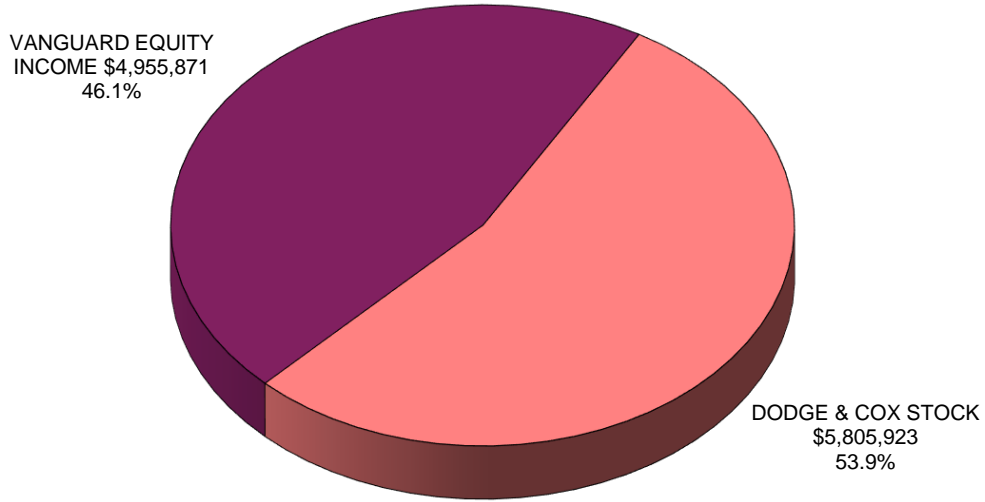

VALUE EQUITY CHARACTERISTICS v. S&P 500

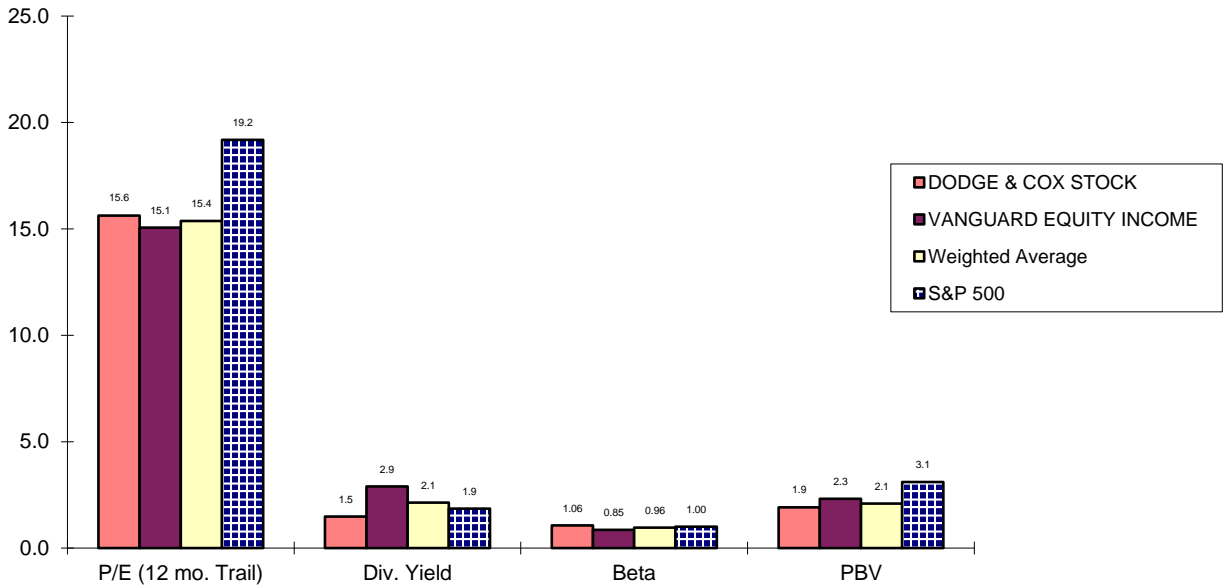

Midwest City Memorial Hospital Authority

Market Value of Fund Plus Real Estate Investments

	Begin MV	Contributions	Gains/(Losses)	PERIOD Distributions For Real Estate Investments	PERIOD Real Estate Sales	Investment End of Period	% ROR	NET Distributions/Sales For Real Estate Investments	Total MV Including Real Estate
1996	0.00	40,000,000	1,894,724			41,894,724	5.00		41,894,724
1997	41,894,724	6,500,000	9,149,906			57,544,631	21.43		57,544,631
1998	57,544,631		10,313,934			67,858,566	17.96		67,858,566
1999	67,858,566		9,842,497	(892,504)		76,808,558	14.66	892,504	77,701,062
2000	76,808,558		1,255,636	(7,530,000)		70,534,196	1.61	8,422,504	78,956,700
2001	70,534,196		(3,474,570)	(17,000,001)	881,724	50,941,348	(4.96)	24,540,781	75,482,129
2002	50,941,348		(6,288,441)	(3,000,000)		41,645,681	(12.42)	27,540,781	69,186,462
2003	41,645,681		8,377,102	(7,000,000)	2,000,000	45,006,531	24.06	32,540,781	77,547,312
2004	45,006,531		5,328,106	(2,000,000)		48,318,461	12.32	34,540,781	82,859,242
2005	48,318,461		3,559,195	(27,212,736)	27,006,977	51,651,524	5.88	34,746,540	86,398,063
2006	51,651,524		7,786,194			59,433,416	15.11	34,746,540	94,179,956
2007	59,433,416		4,280,658	(3,300,000)		60,414,074	7.30	38,046,540	98,460,614
2008	60,414,074		(17,021,674)			43,392,400	(28.12)	38,046,540	81,438,940
2009	43,392,400		8,759,495			52,151,895	21.30	38,046,540	90,198,435
2010	52,151,895		6,528,733	(1,800,000)		56,880,628	9.32	39,846,540	96,727,168
2011	56,880,628		(1,072,322)			55,808,306	(1.79)	39,846,540	95,654,846
2012	55,808,306		7,553,650			63,361,956	13.60	39,846,540	103,208,496
2013	63,361,956		13,845,096			77,207,052	21.94	39,846,540	117,053,592
2014	77,207,052		5,844,036	(5,650,000)		77,401,088	8.46	45,496,540	122,897,628
2015	77,401,088		(143,659)			77,257,429	(0.12)	45,496,540	122,753,969
2016	77,257,429		5,782,378	(5,900,000)		77,139,807	7.84	51,396,540	128,536,347
2017	77,139,807		13,940,808			91,080,615	18.16	51,396,540	142,477,155
2018	91,080,615	2,817,155	(2,862,493)			91,035,277	(2.91)	51,396,540	142,431,817
1q19	91,035,277		9,455,722			100,530,999	10.39	51,396,540	151,927,539
TOTAL		49,317,155	102,634,711	(81,285,240)	29,888,701	100,530,999		51,396,540	151,927,539
						9/30/96 INCEPTION ROR:	7.69%		



NEW BUSINESS/
PUBLIC DISCUSSION





ECONOMIC DEVELOPMENT AUTHORITY AGENDA



The 6:00 PM meetings will be shown live on Channel 20 and streamed live on YouTube.



The recorded video will be available on YouTube and the City's website within 48 hours at www.youtube@midwestcityok.org.



The meeting minutes and video can be found on the City's website in the Agenda Center: <https://midwestcityok.org/AgendaCenter>.



To make a special assistance request, call 739-1215 or email pmeneff@midwestcityok.org no less than 24 hours prior to the start of a meeting. If special assistance is needed during a meeting, call 739-1388.



The Council will go directly into the City meetings down in the Council Chambers of City Hall at 6:00 PM. However, they will informally gather at or after 5:00 PM in the second floor conference room for dinner, but no City Council business will be discussed or acted upon and the room will be open to the public. Meals will only be provided to the City Council and staff.



MIDWEST CITY ECONOMIC DEVELOPMENT AUTHORITY AGENDA

City Hall - Midwest City Council Chambers, 100 N. Midwest Boulevard

May 14, 2019 - 6:03 PM

A. CALL TO ORDER.

B. CONSENT AGENDA.

1. Discussion and consideration of approving the minutes of the special meeting of March 26, 2019, as submitted. (City Clerk - S. Hancock)
2. Discussion and consideration of approving and entering into an agreement with Western Enterprises, Inc. in the amount of \$22,500 to provide a fireworks production for the 4th of July celebration (Tribute to Liberty) at Joe B. Barnes Regional Park on July 4, 2019. (Parks & Recreation - F. Gilles)

C. NEW BUSINESS/PUBLIC DISCUSSION.





CONSENT AGENDA



Notice for the Midwest City Economic Development Authority meeting was filed for the calendar year with the City Clerk of Midwest City. Public notice of this agenda was accessible at least 24 hours before this meeting at City Hall and on the Midwest City website (www.midwestcityok.org).

Midwest City Economic Development Authority Meeting Minutes

March 26, 2019 – 6:03 PM

This meeting was held in the Midwest City Council Chambers, in City Hall, 100 N. Midwest Boulevard, Midwest City, County of Oklahoma, State of Oklahoma.

Chairman Matt Dukes called the meeting to order at 6:58 PM with the following members present: Trustees: Pat Byrne, Española Bowen, Sean Reed, Christine Allen, and Jeff Moore; and Secretary Sara Hancock, City Attorney Heather Poole, and City Manager Guy Henson. Absent: Trustee Susan Eads.

DISCUSSION ITEM.

1. **Discussion and consideration of approving the minutes of the special meeting of February 12, 2019, as submitted.** Reed made a motion to approve the minutes, as submitted, seconded by Byrne. Voting aye: Byrne, Bowen, Reed, Allen, Moore, and Chairman Dukes. Nay: none. Absent: Eads. Motion carried.

NEW BUSINESS/PUBLIC DISCUSSION.

There was no new business or public discussion.

EXECUTIVE SESSION.

1. **Discussion and consideration of 1) entering into executive session, as allowed under 25 O.S. § 307(B)(3), to discuss the purchase or appraisal of real property; and 2) in open session, authorizing the general manager/administrator to take action as appropriate based on the discussion in executive session.** No executive session was needed.

ADJOURNMENT.

There being no further business, Chairman Dukes adjourned the meeting at 6:59 PM.

ATTEST:

MATT DUKES, Chairman

SARA HANCOCK, Secretary



Public Works Administration
Vaughn Sullivan, Director
vsullivan@midwestcityok.org
R. Paul Streets, Assistant Director
rstreets@midwestcityok.org
8730 S.E. 15th Street,
Midwest City, Oklahoma 73110
O: 405-739-1060 /Fax: 405-739-1090

Memorandum

TO: Honorable Chair and Trustees

FROM: Vaughn Sullivan, Public Works Director

DATE: May 14, 2019

SUBJECT: Discussion and consideration of approving and entering into an agreement with Western Enterprises, Inc. in the amount of \$22,500 to provide a fireworks production for the 4th of July celebration (Tribute to Liberty) at Joe B. Barnes Regional Park on July 4, 2019.

In observance of the 2019 July 4th holiday, the City of Midwest City wishes to once again provide a fireworks production located in Regional Park as part of the Tribute to Liberty event. In addition, there will be live music and an evening finale of fireworks choreographed to patriotic music.

Western Enterprises provided an outstanding fireworks display during last year's Independence Day celebration at Joe B. Barnes Regional Park assisting staff in creating a festive atmosphere appealing to patrons of all ages.

Staff recommends approval.

Vaughn Sullivan
Public Works Director

Attachment: Western Enterprises Agreement

FIREWORKS PRODUCTION CONTRACT

1 of 2

1. This Contract is entered into this _____ day of _____, 20____, by and between **WESTERN ENTERPRISES, INC.**, designated herein as the "**SELLER**", and **THE MIDWEST CITY ECONOMIC DEVELOPMENT AUTHORITY AND THE MIDWEST CITY MUNICIPAL AUTHORITY**, designated herein as the "**PURCHASER**" for a fireworks production to be held on **JULY 4, 2019**.

2. **SELLER** will secure, prepare, **design, deliver and stage** said fireworks as outlined in "Attachment A", or will make necessary substitutions of equal or greater value. **SELLER** will include the services of a Pyrotechnic Operator to take charge of, set up and fire the display, along with such help as he deems necessary to perform the fireworks display safely, and in accordance with such Federal, State or Local laws that might be applicable.

3. **SELLER** agrees that the Operator and Assistant(s) are to check the display area after the presentation of the fireworks display for any "duds" or other material that might not have ignited. Any such material, found by any person other than the Operator, shall be returned to the Operator for safe handling or disposal of said material.

4. **PURCHASER** will furnish the secured minimum safety distances established by the **SELLER** after an on-site inspection of the proposed firing location. **PURCHASER** will provide adequate police protection and/or other adequate security to maintain these distances. **PURCHASER** also agrees to have a fire truck available on location during the display.

5. A Certificate of Insurance covering the fireworks display will be provided by the **SELLER** upon signing of the contract, for coverage in the amount of **FIVE MILLION DOLLARS (\$5,000,000.00)** broad form, bodily injury and property damage liability, Statutory Workers Compensation Coverage, Comprehensive Automobile Liability in the amount of **FIVE MILLION DOLLARS (\$5,000,000.00)** Combined Single Limit. **PURCHASER** agrees to provide a complete list of all additional insureds to be named on the certificate. Those entities/individuals listed on the certificate of insurance shall be deemed as additional insured per this contract.

6. It is agreed and understood that the **PURCHASER** will pay to the **SELLER** the sum of **TWENTY-TWO THOUSAND FIVE DOLLARS & NO/100 (\$22,500.00)** to be paid **within thirty (30) days after the date of the display**. **HOWEVER**, if payment is made in full by April 17, 2019, a five percent (5%) discount (**\$1,200.00**) will apply. That discount can either be deducted from the total contract price, or the **PURCHASER** may elect to receive that amount of extra pyrotechnic product in lieu of the discount. Unpaid accounts are subject to one percent (1%) interest charge per month after **thirty** days.

7. In the event of inclement weather or other adverse conditions, so as to cause postponement of the display it is agreed and understood that **PURCHASER** will notify **SELLER** regarding the postponement date, normally the following night, or at some future date within the calendar year. If the **PURCHASER** will not re-schedule the display within the calendar year, or completely cancels the display, **the PURCHASER agrees and understands that a 30% cancellation fee (\$6,750.00) of the full contract amount will apply. This amount will be deemed as full payment for cancellation of the display.** If the **PURCHASER** has exercised the "Early-Payment Option" for discount; the difference between the 30% cancellation fee and the early-payment amount will be refunded to the **PURCHASER**.

It is understood and agreed that **SELLER** shall be solely responsible for failure of the performance of the fireworks display for any reason under **SELLERS** control.

FIREWORKS PRODUCTION CONTRACT

2 of 2

8. Witness whereof, we have caused our signatures to be affixed to this Document, on this _____ day of _____, 20__.

WESTERN ENTERPRISES, INC.
SELLER

MIDWEST CITY
ECOMONIC DEVELOPMENT AUTHORITY
PURCHASER

BY: _____
Authorized agent

BY: _____
CHAIRMAN, Matthew D. Dukes II

MIDWEST CITY MUNICIPAL AUTHORITY
PURCHASER

BY: _____
CHAIRMAN, Matthew D. Dukes II

(SIG) _____
Notary Public

Notary Public in and for the State of Oklahoma

My Commission Expires: _____

My Commission #: _____

ATTEST:

SECRETARY, Sara Hancock

APPROVED as to form and legality this _____ day of _____, 2019.

AUTHORITY COUNSEL, Heather Poole



NEW BUSINESS/
PUBLIC DISCUSSION

