







MIDWEST CITY COUNCIL MEETING

AGENDA FOR

February 12, 2019

-  6:00 PM meetings will be shown live on Channel 20.
-  The recorded video will be available on Youtube and the City's website within 48 hours at www.youtube@midwestcityok.org.
-  The meeting minutes and video can be found on the City's website in the Agenda Center: <https://midwestcityok.org/AgendaCenter>.
-  To make a special assistance request, call 739-1215 or email pmenefee@midwestcityok.org no less than 24 hours prior to the start of a meeting. If special assistance is needed during a meeting, call 739-1388.



CITY OF MIDWEST CITY COUNCIL AGENDA

City Hall - Midwest City Council Chambers, 100 N. Midwest Boulevard

February 12, 2019 – 6:00 PM

A. **CALL TO ORDER.**

B. **OPENING BUSINESS.**

- Invocation by Public Works Director Vaughn Sullivan
- Pledge of Allegiance by Carl Albert Jr. ROTC Cadets Mercedes Hirsch and Curtis Eckart
- Community-related announcements and comments

C. **CONSENT AGENDA.** These items are placed on the Consent Agenda so the Council, by unanimous consent, can approve routine agenda items by one motion. If any item proposed does not meet with the approval of all Council, or members of the audience wish to discuss an item, it will be removed and heard in a regular order.

1. Discussion and consideration of approving the minutes of the regular meeting of January 22, 2019, as submitted. (City Clerk - S. Hancock)
2. Discussion and consideration of supplemental budget adjustments to the following funds for FY 2018-2019, increase: Park & Recreation Fund, revenue/Miscellaneous \$22,089; expenses/Park & Rec (06) \$22,089. General Gov't Sales Tax Fund, expenses/General Gov't (14) \$28,934. (Finance - C. Barron)
3. Discussion and consideration of approving and entering into a contract with RSM US, LLP to perform a compilation of the 2018 SA&I Form 2643. (C. Barron - Finance)
4. Discussion and consideration of the acceptance of and making a matter of record Permit No. SL000055180751 from the State Department of Environmental Quality for the 10225 East Reno Avenue Sewer Line Connection, Midwest City, Oklahoma. (Community Development - P. Menefee)
5. Discussion and consideration of the acceptance of and making a matter of record Permit No. WL000055180734 from the State Department of Environmental Quality for the S.E. 29th Street Water Line Extension Project (Oak Avenue to Post Road), Midwest City, Oklahoma. (Community Development - P. Menefee)
6. Discussion and consideration of approving the following sidewalk projects for potential construction in calendar year 2019 and utilizing the Sidewalk Fee and Sidewalk/Trails Fee Funds. (Community Development - P. Menefee)
7. Discussion and consideration of entering into a project agreement for Federal-aid Project Number STP-155E(919)EH, State Job Number 28817(04), with the Oklahoma Department of Transportation to receive federal funds in the amount of \$600,000.00 to construct the Midwest City Mid-America Park Trail. (Community Development - P. Menefee)

8. Discussion and consideration of entering into a project agreement for Federal-aid Project Number STP-255B(461)AG, State Job Number 31548(04) with the Oklahoma Department of Transportation to receive federal funds in the amount of \$2,984,000.00 to construct the Midwest City Reconstruction of SE 29th Street from Midwest Boulevard to Douglas Boulevard including the SE 29th Street Midwest Boulevard intersection, but not the Douglas Boulevard SE 29th Street intersection. (Community Development - P. Menefee)
9. Discussion and consideration of entering into a project agreement for Federal-aid Project Number NHPP-255N(496) AG, State Job Number 31546(04), with the Oklahoma Department of Transportation to receive federal funds in the amount of \$1,760,000.00 to mill, resurface, and reconstruct the sidewalk on Douglas Boulevard from SE 4th Street to NE 10th Street. (Community Development - P. Menefee)
10. Discussion and consideration of entering into a project agreement for Federal-aid Project Number STPG-255F(482)AG, State Job Number 33739(04), with the Oklahoma Department of Transportation to receive federal funds in the amount of \$466,000.00 to construct the Midwest City Signals to be installed at the following two intersections: Douglas Boulevard and Orchard Boulevard and Air Depot at the Rail with Trail crossing. (Community Development - B. Harless)
11. Discussion and consideration of declaring ninety-seven (97) firearms of various calibers as surplus and authorizing their disposal by trade-in toward future purchases with GT Distributors, Austin, Texas for a trade-in amount of \$7,010.00. (Police - B. Clabes)
12. Discussion and consideration of 1) declaring various computer equipment obsolete items of city property on the attached list surplus; and 2) authorizing their disposal by public auction or sealed bid. (Information Technology - R. Rushing)

D. DISCUSSION ITEMS.

1. Consider the award of the sale of General Obligation Bonds of the City of Midwest City, Oklahoma, in the amount of Twenty Million and no/100s dollars (\$20,000,000.00) to the lowest bidder. (City Clerk - S. Hancock)
2. Consider and adopt Ordinance 3359 providing for the issuance of General Obligation Bonds in the sum of twenty million and no/100s dollars (\$20,000,000.00) by the City of Midwest City, Oklahoma authorized at an election duly called and held for such purpose; prescribing form of bonds; providing for registration thereof; providing for a system of registration for uncertificated registered public obligations; providing levy of an annual tax for payment of principal and interest on the same; fixing other details of the issue; and declaring an emergency. (City Clerk - S. Hancock)
3. Consider and vote to approve a resolution relating to the incurring of indebtedness by the Trustees of the Midwest City Municipal Authority; waiving competitive bidding; approving a sales tax agreement; and containing other provisions relating thereto. (S. Hancock - City Clerk)

4. Discussion and consideration of accepting the Oklahoma Spartans Youth Organization (OSYO) FY 2017-18 revised financial statement. (Parks and Rec. - F. Gilles)
 5. Discussion and consideration of the approval of the Collective Bargaining Agreement between the City of Midwest City and the International Association of Firefighters Local (IAFF) #2066 as negotiated to be effective from July 1, 2018 to June 30, 2020. (Human Resources - C. Wilson)
- E. NEW BUSINESS/PUBLIC DISCUSSION. The purpose of the "Public Discussion Section" of the Agenda is for members of the public to speak to the City Council on any Subject not scheduled on the Regular Agenda. The Council shall make no decision or take any action, except to direct the City Manager to take action, or to schedule the matter for discussion at a later date. Pursuant to the Oklahoma Open Meeting Act, the Council will not engage in any discussion on the matter until that matter has been placed on an agenda for discussion. THOSE ADDRESSING THE COUNCIL ARE REQUESTED TO STATE THEIR NAME AND ADDRESS PRIOR TO SPEAKING TO THE COUNCIL.
- F. EXECUTIVE SESSION.
1. Discussion and consideration of entering into executive session, as allowed under 25 O.S., Section 307(B)(4), to discuss Robert Toney, et al., v. City of Midwest City, case No. CJ-2015-3307, and (2) in open session, authorizing the city manager to take action as appropriate based on the discussion in executive session.
- G. FURTHER INFORMATION.
1. Minutes of the January 22, 2019 Sidewalk Committee Meeting. (Community Development - P. Menefee)
 2. Discussion and consideration of passing an ordinance amending the Midwest City Code, Chapter 28, Offenses – Miscellaneous, Article IV, Offenses Against Property, Section 28-57.1, False checks, to include violations less than \$1,000 in the definition of a misdemeanor; and providing for repealer and severability. (City Prosecutor - J. Horn)
 3. Discussion and consideration of passing an ordinance amending the Midwest City Code, Chapter 24, Motor Vehicles, Article II, Administration and Enforcement, Division 2, Vehicle Impoundment, Section 24-44, Authorized, to permit the Police Department to tow a vehicle when the license plate has been altered or the officer has probable cause to believe the vehicle is not insured; and providing for repealer and severability. (City Prosecutor - J. Horn)
 4. Discussion and consideration of passing and approving an ordinance amending the Midwest City Municipal Code, Chapter 18, Garbage and Refuse, by amending Article I, in General Section 18-8 Bulk Waste Collection; Article II, Municipal Collection and Disposal Service, Section 18-22(c), City to Furnish Service, Section 18-25(b) and 18-25(f), Container Required, Duty to Use; Section 18-27(a), Residential Service Fees; Special Provisions for Mobile Home Parks; Section 18-28, Business and Commercial Service Fees; Section 18-31, Special Charge for Restoration of Service to Commercial Establishments; and providing for repealer and severability. (Public Works - R. Paul Streets)
- H. ADJOURNMENT.



CONSENT AGENDA



A notice for the Midwest City Council was filed for the calendar year with the City Clerk of Midwest City. Public notice of this agenda was accessible at least 24 hours before this meeting at City Hall and on the Midwest City website (www.midwestcityok.org).

Midwest City Council Minutes

January 22, 2019 – 6:00 PM

This meeting was held in the Midwest City Council Chambers at City Hall, 100 N. Midwest Boulevard, Midwest City, County of Oklahoma, State of Oklahoma.

Mayor Matt Dukes called the meeting to order at 6:01 PM with the following members present: Councilmembers Susan Eads, Española Bowen, Sean Reed, and Christine Allen with City Clerk Sara Hancock, City Attorney Heather Poole, and Acting City Manager Tim Lyon. Absent: Pat Byrne and Jeff Moore.

Opening Business. Public Works Director Vaughn Sullivan opened with the invocation, followed by the Pledge of Allegiance led by Councilmember Reed. Council and Staff made community-related announcements.

Consent Agenda. Eads made a motion to approve the consent agenda, as submitted, seconded by Reed. Voting aye: Eads, Bowen, Reed, Allen, and Mayor Dukes. Nay: none. Absent: Byrne and Moore. Motion carried.

1. Discussion and consideration of approving the minutes of the regular meeting of January 8, 2019, as submitted.
2. Discussion and consideration of supplemental budget adjustments to the following funds for FY 2018-2019, increase: 2018 Election G.O. Bonds Fund, expenses/ Animal Welfare (10) \$305,000. Grants Fund, revenue/Intergovernmental (21) \$20,000; expenses/Transfers Out (21) \$20,000. Emergency Operations Fund, revenue/Transfers In (00) \$20,000.
3. Discussion and consideration of accepting the City Manager's Report for the month of December, 2018.
4. Discussion and consideration of accepting the monthly report on the City of Midwest City Employees' Health Benefits Plan by the City Manager and action as deemed necessary by the Council to maintain the plan.
5. Discussion and consideration of approving the Mayor's appointments of Gary Bachman, David Howell and Adam Bush as Municipal Judges and Alternate Judges.
6. Discussion and consideration of a quarterly update on the progress of the execution of the Bond projects.
7. Discussion and consideration of granting award to Safety Com, Inc. In the amount of \$330,250.00 for (10), outdoor warning Sirens, including poles and related hardware.
8. Discussion and consideration of the Monthly Neighborhood Services report for December 2018.

9. Discussion and consideration of the acceptance of and making a matter of record Permit No. WL000055180976 from the State Department of Environmental Quality for the N.E. 23rd Street Water Line Improvement Project, Midwest City, Oklahoma.
10. Discussion and consideration of accepting a Waterline Easement for the construction of a public water main extension located at and across 9601 S.E. 29th Street. The easement is located within the corporate limits of the City of Midwest City, located in the Southeast Quarter of Section Twelve (12), Township Eleven (11) North, Range Two (2) West of the Indian Meridian, Oklahoma County, Oklahoma.
11. Discussion and consideration of approving Resolution 2019-03 relating to the reimbursement to the City of Midwest City Police Department 020 Fund of approximately \$305,000.00 of the total animal welfare center bond project for payment of professional architectural services to create a scope design and construction documents associated with the new animal welfare center.
12. Discussion and consideration of withdrawing Councilmember Allen's citizen nominee to the Animal Ordinance Review Committee Ronald Still and nominating Ronald Demas as Ward 5 nominee.
13. Discussion and consideration of withdrawing Councilmember Bowen's nominee, Mr. Thomas Galbraith, from the Parks and Recreation Board.
14. Discussion and consideration of declaring as surplus property One (1) Exterior Lights, Cooper Lighting MFG. model #HPNK-Y76-100-MT part #7360168001 volts 120/208/240/277, One (1) Stihl chain saw MS260 serial #7360168001 equipment # 09- 09-46, One (1) Stihl chain saw 036 PRO serial #241094654, equipment # 09-09-06, One (1) Stihl chain saw MS261C serial #501717016 equipment # 09-07-130 and Two (2) Life Guard chairs.
15. Discussion and consideration of 1) declaring the various obsolete items of city property on the attached list surplus; and 2) authorizing their disposal by public auction or sealed bid.

Discussion Items.

1. **(PC – 1976) Discussion and consideration of approval of the Preliminary Plat of Florence Estates for the property described as a part of the NE/4 of Section 1, T-11-N, R-1-W, located in the 400 block of S. Post Road. This item was continued from the October 2, 2018 and November 6, 2018 Planning Commission meetings and the October 23, 2018 and November 27, 2018 Council meetings.** No action needed.
2. **Discussion and consideration of the final report concerning the implementation of the ESCI study.** Chief Norton addressed the Council and after discussion, Eads made a motion to accept the report, as submitted, seconded by Reed. Voting aye: Eads, Bowen, Reed, Allen, and Mayor Dukes. Nay: none. Absent: Byrne and Moore. Motion carried.
3. **Discussion and consideration regarding the final Matrix implementation progress report based on the Midwest City Police Department study conducted from July 2016 through January 2017 by Matrix Consulting Group.** Chief Clabes and Major Cornelison addressed the Council and after discussion, Allen made a motion to accept the report, as submitted, seconded by Eads. Voting aye: Eads, Bowen, Reed, Allen, and Mayor Dukes. Nay: none. Absent: Byrne and Moore. Motion carried.

4. **A resolution for the city council of the City of Midwest City relating to supporting the “Smart on Crime Approach”, developed by the Oklahoma Department of Mental Health and Substance Abuse Services (ODMHSAS), which could create an opportunity for the state and Midwest City to avoid millions of dollars in future law enforcement and criminal justice expenses, along with other expenses that result from untreated brain disease, in addition to improving the lives of thousands upon thousands of Oklahoma families.** Jeff Dismukes, ODMHSAS Representative, Staff and Council had discussion, after which, Eads made a motion to approve Resolution 2019-02, seconded by Bowne. Voting aye: Eads, Bowen, Reed, Allen, and Mayor Dukes. Nay: none. Absent: Byrne and Moore. Motion carried.

New Business/Public Discussion.

Further Information.

1. **Discussion and consideration of reviewing the results of the community questionnaire regarding bulky item disposal preferences.** Staff and Council had discussion,

At 6:45 PM, Reed made a motion to recess, seconded by Eads. Voting aye: Eads, Bowen, Reed, Allen, and Mayor Dukes. Nay: none. Absent: Byrne and Moore. Motion carried.

The Council reconvened at 6:50 PM with a motion by Eads, seconded by Reed. Voting aye: Eads, Bowen, Reed, Allen, and Mayor Dukes. Nay: none. Absent: Byrne and Moore. Motion carried.

Executive Session.

1. **Discussion and consideration of entering into executive session as allowed under 25 O.S., § 307(B)(7) to be briefed on information where public disclosure will violate confidentiality requirements.**

At 6:51 PM, Allen made a motion to enter into executive session, seconded by Eads. Voting aye: Eads, Bowen, Reed, Allen, and Mayor Dukes. Nay: none. Absent: Byrne and Moore. Motion carried.

At 7:21 PM, Allen made a motion to return to open session, seconded by Bowen. Voting aye: Eads, Bowen, Reed, Allen, and Mayor Dukes. Nay: none. Absent: Byrne and Moore. Motion carried. No action was taken.

Adjournment. There being no further business, Mayor Dukes adjourned the meeting at 7:22 PM.

ATTEST:

MATTHEW D. DUKES II, Mayor

SARA HANCOCK, City Clerk



The City of MIDWEST CITY

100 N. MIDWEST BLVD * MIDWEST CITY, OKLAHOMA 73110
(405) 739-1245 * FAX (405) 739-1247 * TDD (405) 739-1359

Memorandum

TO: Honorable Mayor and Council

FROM: Christy Barron, Finance Director

DATE: February 12, 2019

Subject: Discussion and consideration of supplemental budget adjustments to the following funds for FY 2018-2019, increase: Park & Recreation Fund, revenue/Miscellaneous (06) \$22,089; expenses/Park & Rec (06) \$22,089. General Gov't Sales Tax Fund, expenses/General Gov't (14) \$28,934.

The first supplement is needed to budget insurance recovery from damaged skate park equipment and expenses for replacement equipment. The second supplement is needed to budget expense for City Strategic Plan approved by Council January 8th, 2019.

Christy Barron
Finance Director

SUPPLEMENTS

February 12, 2019

Fund PARK & RECREATION (123)		BUDGET AMENDMENT FORM Fiscal Year 2018-2019			
		Estimated Revenue		Budget Appropriations	
<u>Dept Number</u>	<u>Department Name</u>	<u>Increase</u>	<u>Decrease</u>	<u>Increase</u>	<u>Decrease</u>
06	Miscellaneous	22,089			
06	Park & Rec			22,089	
		22,089	0	22,089	0
Explanation:					
To budget insurance recovery from damaged skate park equipment and expense for replacement equipment.					

Fund GENERAL GOV'T SALES TAX (009)		BUDGET AMENDMENT FORM Fiscal Year 2018-2019			
		Estimated Revenue		Budget Appropriations	
<u>Dept Number</u>	<u>Department Name</u>	<u>Increase</u>	<u>Decrease</u>	<u>Increase</u>	<u>Decrease</u>
14	General Gov't			28,934	
		0	0	28,934	0
Explanation:					
To budget expense for City Strategic Plan approved by Council January 8th, 2019. Funding to come from fund balance					



The City of MIDWEST CITY

100 N. MIDWEST BLVD * MIDWEST CITY, OKLAHOMA 73110
(405) 739-1245 * FAX (405) 739-1247 * TDD (405) 739-1359

Memorandum

TO: Honorable Mayor and Council

FROM: Christy Barron, Finance Director

DATE: February 12, 2018

SUBJECT: Discussion and consideration of approving and entering into a contract with RSM US, LLP to perform a compilation of the 2018 SA&I Form 2643.

The Finance Department has been in communication with Mike Gibson of RSM US, LLP concerning the compilation of the SA&I (State Auditor and Inspector) Form 2643 which we are statutorily required to file on a yearly basis according to 11 O.S. §17-105. There are no costs associated with this agreement, because the costs were included in the amount paid for the 2018 Financial Statement audit.

It is recommended that the attached engagement letter be approved.

Christy Barron
Finance Director

Attachments: SA&I Form 2643 Compilation Engagement Letter



July 10, 2018

Mr. Matt Dukes
Mayor
100 N. Midwest Boulevard
Midwest City, OK 73140

RSM US LLP

210 Park Avenue
Suite 1725
Oklahoma City, OK 73102
T +1 405 239 7961
F +1 405 235 0042
www.rsmus.com

Attention: Mr. Dukes:

This letter is to confirm our understanding of the terms and objectives of our engagement and the nature and limitations of the services we will provide.

We will perform the following services:

We will compile, from information you provide, the 2018 Annual Survey of City and Town Finances (SA&I Form 2643), and issue an accountant's report thereon in accordance with Statements on Standards for Accounting and Review Services (SSARs) issued by the American Institute of Certified Public Accountants (AICPA).

The objective of a compilation is to assist you in presenting financial information in the prescribed form. We will utilize information that is your representation without undertaking to obtain or provide any assurance that there are no material modifications that should be made to the financial information in the prescribed form in order for the Annual Survey (SA&I Form 2643) to be in conformity with the basis of accounting prescribed by Oklahoma State Auditor and Inspector pursuant to Section 17-105.1 of Title 11 of the Oklahoma Statutes.

You are responsible for

- a. the preparation and fair presentation of the financial information in Annual Survey (SA&I Form 2643) in accordance with the basis of accounting prescribed by Oklahoma State Auditor and Inspector pursuant to Section 17-105.1 of Title 11 of the Oklahoma Statutes.
- b. designing, implementing, and maintaining internal control relevant to the preparation and fair presentation of the financial information in the prescribed form.
- c. preventing and detecting fraud
- d. identifying and ensuring that the entity complies with the laws and regulations applicable to its activities.
- e. making all financial records and related information available to us.

We are responsible for conducting the engagement in accordance with SSARs issued by the AICPA.

THE POWER OF BEING UNDERSTOOD
AUDIT | TAX | CONSULTING

A compilation differs significantly from a review or an audit of financial statements. A compilation does not contemplate performing inquiry, analytical procedures, or other procedures performed in a review. Additionally, a compilation does not contemplate obtaining an understanding of the entity's internal control; assessing fraud risk; testing accounting records by obtaining sufficient appropriate audit evidence through inspection, observation, confirmation, or the examination of source documents (for example, cancelled checks or bank images); or other procedures ordinarily performed in an audit. Accordingly, we will not express an opinion or provide any assurance regarding the financial information included in the Annual Survey (SA&I Form 2643).

Our engagement cannot be relied upon to disclose errors, fraud, or illegal acts. However, we will inform the appropriate level of management of any material errors, and of any evidence or information that comes to our attention during the performance of our compilation procedures that fraud may have occurred. In addition, we will report to you any evidence or information that comes to our attention during the performance of our compilation procedures regarding illegal acts that may have occurred, unless they are clearly inconsequential.

Because RSM US, LLP will rely on the City of Midwest City and its management to discharge the foregoing responsibilities, the City of Midwest City holds harmless and releases RSM US, LLP, its partners, and employees from all claims, liabilities, losses, and costs arising in circumstances where has been a known misrepresentation by a member of the City of Midwest City's management, which has caused, in any respect, RSM US, LLP's breach of contract or negligence. This provision shall survive the termination of this arrangement for services.

We will render such accounting and bookkeeping assistance as we find necessary for the preparation of the compilation of the Annual Survey (SA&I Form 2643) and as may be arranged with you or your authorized employees. You will be responsible for overseeing such services, evaluating the adequacy and accepting the results of these services, and for making all management decisions with respect to the services.

If, for any reason, we are unable to complete the compilation of the Annual Survey (SA&I Form 2643), we will not issue a report on such statements as a result of this engagement.

During the course of our engagement, we may accumulate records containing data that should be reflected in your books and records. You will determine that all such data will be so reflected. Accordingly, you will not expect us to maintain copies of such records in our possession.

The assistance to be supplied by your personnel in the preparation of schedule and analyses of accounts has been discussed and coordinated with you. The timely and accurate completion of this work is an essential condition to our completion of the engagement and issuance of our compilation report.

Our fees for these services are based on the time required by individuals assigned to the engagement, plus direct expenses.

In the event we are requested or authorized by the City of Midwest City or are required by government regulation, subpoena, or other legal process to produce our documents or our personnel as witnesses with respect to our engagements for the City of Midwest City, the City of Midwest City will, so long as we are not party to the proceeding in which the information is sought, reimburse us for our professional time and expenses, as well as the fees and expenses of our counsel, incurred in responding to such requests.

The City of Midwest City and RSM US, LLP agree that no claim arising out of services rendered pursuant to this agreement shall be filed more than two years after the date of the report issued by RSM US, LLP or the date of this arrangement letter if no report has been issued. The City of Midwest City waives any claim for punitive damages. RSM US, LLP's liability for all claims, damages, and costs of the City of

Mayor
City of Midwest City
July 10, 2018
Page 3

Midwest City arising from this engagement is limited to the amount of fees paid by the City of Midwest City to RSM US, LLP for the services rendered under this arrangement letter.

This letter constitutes the complete and exclusive statement of the agreement between RSM US, LLP, superseding all proposals oral or written and all other communications, with respect to the terms of the engagement between parties.

We will be pleased to discuss this letter with you at any time. If the foregoing is in accordance with your understanding, please sign this letter in the space provided and return it to us.

RSM US LLP

A handwritten signature in black ink, appearing to read "Mike Gibson", with a long horizontal line extending to the right.

Mike Gibson, Partner

Acknowledged:

City of Midwest City, Oklahoma

Mayor

ATTEST:

Sara Hancock, City Clerk

Approved as to form and legality this ____ day of
February, 2019

Heather Poole, City Attorney



The City of
MIDWEST CITY
COMMUNITY DEVELOPMENT DEPARTMENT -
ENGINEERING DIVISION

Billy Harless, Community Development Director
Patrick Menefee, P.E., City Engineer

ENGINEERING DIVISION
Patrick Menefee, City Engineer
CURRENT PLANNING DIVISION
Kellie Gilles, Manager
COMPREHENSIVE PLANNING
, Comprehensive Planner
BUILDING INSPECTION DIVISION
Christine Brakefield, Building Official
GIS DIVISION
Greg Hakman, GIS Coordinator

To: Honorable Mayor and Council

From: Patrick Menefee, P.E., City Engineer

Date: February 12th, 2019

Subject: Discussion and consideration of the acceptance of and making a matter of record Permit No. SL000055180751 from the State Department of Environmental Quality for the 10225 East Reno Avenue Sewer Line Connection, Midwest City, Oklahoma.

Permit No. SL000055180751 is for the construction of 925 L.F. of eight inch (8") sewer line to serve the 10225 East Reno Avenue Sewer Line Connection, Midwest City, Oklahoma.

Staff recommends acceptance as this is consistent with past policy.

Patrick Menefee, P.E.
City Engineer



SCOTT A. THOMPSON
Executive Director

OKLAHOMA DEPARTMENT OF ENVIRONMENTAL QUALITY

MARY FALLON
Governor

December 28, 2018

Mr. Tim Lyon, Acting City Manager
City of Midwest City
100 North Midwest Boulevard
Midwest City, Oklahoma 73110

Re: Permit No. SL000055180751
10225 East Reno Avenue Sewer Line Connection
Facility No. S-20541

Dear Mr. Lyon:

Enclosed is Permit No. SL000055180751 for the construction of 925 linear feet of eight (8) inch PVC sanitary sewer line and all appurtenances to serve the 10225 East Reno Avenue Sewer Line Connection, in Oklahoma County, Oklahoma.

The project authorized by this permit should be constructed in accordance with the plans approved by this Department on December 28, 2018. Any deviations from the approved plans and specifications affecting capacity, flow or operation of units must be approved, in writing, by the Department before changes are made.

Receipt of this permit should be noted in the minutes of the next regular meeting of the City of Midwest City, after which it should be made a matter of permanent record.

We are returning one (1) set of the approved plans to you, one (1) set to your engineer and retaining one (1) set for our files.

Respectfully,

A handwritten signature in blue ink, appearing to read "Robert Walker", is written over a light blue circular stamp.

Robert Walker
Construction Permit Section
Water Quality Division

RBW/RR/RC/ag

Enclosure

c Travis Mensik, Regional Manager, DEQ
OKLAHOMA CITY DEQ OFFICE
David H. Recht, DHR Engineering, Inc.
E.D. Hill, Senior, E.D Hill Surveying & Engineering Co.





SCOTT A. THOMPSON
Executive Director

OKLAHOMA DEPARTMENT OF ENVIRONMENTAL QUALITY

MARY FALLIN
Governor

PERMIT TO CONSTRUCT

December 28, 2018

Pursuant to O.S. 27A 2-6-304, the City of Midwest City is hereby granted this Tier I Permit to construct 925 linear feet of eight (8) inch PVC sanitary sewer line and all appurtenances to serve the 10225 East Reno Avenue Sewer Line Connection, located in the S 1/2, SW1/4, SE 1/4, SW 1/4 of Section 31, T-12-S, R-1-W, Oklahoma County, Oklahoma, in accordance with the plans approved December 28, 2018.

By acceptance of this permit, the permittee agrees to operate and maintain the facilities in accordance with the "Oklahoma Pollutant Discharge Elimination System Standards - OPDES" (OAC 252:606) rules and to comply with the state certification laws, Title 59, Section 1101-1116 O.S. and the rules and regulations adopted thereunder regarding the requirements for certified operators.

This permit is issued subject to the following provisions and conditions.

- 1) That the recipient of the permit is responsible that the project receives supervision and inspection by competent and qualified personnel.
- 2) That construction of all phases of the project will be started within one year of the date of approval or the phases not under construction will be resubmitted for approval as a new project.
- 3) That no significant information necessary for a proper evaluation of the project has been omitted or no invalid information has been presented in applying for the permit.
- 4) That wherever water and sewer lines are constructed with spacing of 10 feet or less, sanitary protection will be provided in accordance with OAC 252:656-5-4(c)(3) of the standards for Water Pollution Control Facility Construction.
- 5) That tests will be conducted as necessary to insure that the construction of the sewer lines will prevent excessive infiltration and that the leakage will not exceed 10 gallons per inch of pipe diameter per mile per day.
- 6) That the Oklahoma Department of Environmental Quality shall be kept informed of occurrences which may affect the eventual performance of the works or that will unduly delay the progress of the project.
- 7) That the permittee will take steps to assure that the connection of house services to the sewers is done in such a manner that the functioning of the sewers will not be impaired and that earth and ground water will be excluded from the sewers when the connection is completed.



SCOTT A. THOMPSON
Executive Director

OKLAHOMA DEPARTMENT OF ENVIRONMENTAL QUALITY

MARY FALLIN
Governor

PERMIT TO CONSTRUCT

- 8) That any deviations from approved plans or specifications affecting capacity, flow or operation of units must be approved by the Department before any such deviations are made in the construction of this project.
- 9) That the recipient of the permit is responsible for the continued operation and maintenance of these facilities in accordance with rules and regulations adopted by the Environmental Quality Board, and that this Department will be notified in writing of any sale or transfer of ownership of these facilities.
- 10) The issuance of this permit does not relieve the responsible parties of any obligations or liabilities which the permittee may be under pursuant to prior enforcement action taken by the Department.
- 11) That the permittee is required to inform the developer/builder that a DEQ Storm Water Construction Permit is required for a construction site that will disturb one (1) acre or more in accordance with OPDES, 27A O.S. 2-6-201 *et seq.* For information or a copy of the GENERAL PERMIT (OKR10) FOR STORM WATER DISCHARGES FROM CONSTRUCTION ACTIVITIES, Notice of Intent (NOi) form, Notice of Termination (NOT) form, or guidance on preparation of a Pollution Prevention Plan, contact the Storm Water Unit of the Water Quality Division at P.O. Box 1677, Oklahoma City, OK 73101-1677 or by phone at (405) 702-8100.
- 12) That all manholes shall be constructed in accordance with the standards for Water Pollution Control Facility Construction (OAC 252:656-5-3), as adopted by the Oklahoma Department of Environmental Quality.
- 13) That when it is impossible to obtain proper horizontal and vertical separation as stipulated in Water Pollution Control Facility Construction OAC 252:656-5-4(c)(1) and OAC 252:656-5-4(c)(2), respectively, the sewer shall be designed and constructed equal to water pipe, and shall be pressure tested using the ASTM air test procedure with no detectable leakage prior to backfilling, in accordance with the standards for Water Pollution Control Facility Construction OAC 252:656-5-4(c)(3).

Failure to appeal the conditions of this permit in writing within 30 days from the date of issue will constitute acceptance of the permit and all conditions and provisions.

AR

Rocky Chen, P.E., Engineering Manager, Construction Permit Section
Water Quality Division

THE CITY OF MIDWEST CITY

M. J. Hanku
Mayor

Susan Fads,
Mayor



Pat Byrne,
Mayor



L. Manola Bowen,
Mayor

of 0

Tr. Moore,
Mayor

J. J. Henson,
City Manager

Sara Hancock,
City Clerk

SANITARY SEWER QUANTITY SUMMARY

Item	Quantity	Unit
1. 4" PVC 10' length	1	Lf.
14. 4" Bellows	1	EA
1. 4" Trench	1	LF

SANITARY SEWER- PLANS FOR 10225 E. RENO AVENUE

STATE OF OKLAHOMA OF MIDWEST, OKLAHOMA COUNTY, OK
DEPARTMENT OF ENVIRONMENTAL QUALITY

APPROVED

DEC 28 2018

Rocky W. Chen, P.E.
Water Quality Division

B. W. Klker

Copy

Sanitary Sewer Standards - Construction Standards - Watertight Covers
In accordance with OAC 252:656-5-4(g)(8), use watertight covers on manholes with rim elevations below the 100-year flood elevation, or otherwise subject to surface storm water submergence.

Sanitary Sewer Standards - Construction Standards - Manholes - Leakage Tests
In accordance with OAC 252:656-5-4(g)(7), conduct leakage tests on all new manholes in accordance with latest version of ASTM C 969 or 1244.

Sanitary Sewer Standards - Construction Standards - 100' Minimum Cover Test
In accordance with OAC 252:656-5-5(b), leakage tests are required for all gravity lines. Hydrostatic tests must be in accordance with the ASTM standard for the test to be used. Use a 2-foot test bead and leakage inward or outward must not exceed 30 gallons per inch of pipe diameter per mile per day. The procedures listed in the Handbook of PVC Pipe, Uni-Bell PVC Pipe Association, 2001 may be used for PVC pipe.

DEC 21 2018
WATER QUALITY DIVISION
NEW 01 11-11-2018

GENERAL CONSTRUCTION NOTES

- G1. The Contractor shall provide for the protection of all existing utility lines located within the project limits. The Contractor shall verify the location and depth of all existing utility lines (including water, gas, electric, fiber optic, and sewer) prior to construction. If any utility lines are located within the project limits, the Contractor shall provide appropriate protection and shall be responsible for any damage to such lines. A record of all utility lines located within the project limits shall be provided to the City of Midwest City.
- G2. The Contractor shall be responsible for the protection of all existing utility lines located within the project limits. The Contractor shall verify the location and depth of all existing utility lines (including water, gas, electric, fiber optic, and sewer) prior to construction. If any utility lines are located within the project limits, the Contractor shall provide appropriate protection and shall be responsible for any damage to such lines. A record of all utility lines located within the project limits shall be provided to the City of Midwest City.
- G3. The Contractor shall be responsible for the protection of all existing utility lines located within the project limits. The Contractor shall verify the location and depth of all existing utility lines (including water, gas, electric, fiber optic, and sewer) prior to construction. If any utility lines are located within the project limits, the Contractor shall provide appropriate protection and shall be responsible for any damage to such lines. A record of all utility lines located within the project limits shall be provided to the City of Midwest City.
- G4. The Contractor shall be responsible for the protection of all existing utility lines located within the project limits. The Contractor shall verify the location and depth of all existing utility lines (including water, gas, electric, fiber optic, and sewer) prior to construction. If any utility lines are located within the project limits, the Contractor shall provide appropriate protection and shall be responsible for any damage to such lines. A record of all utility lines located within the project limits shall be provided to the City of Midwest City.
- G5. The Contractor shall be responsible for the protection of all existing utility lines located within the project limits. The Contractor shall verify the location and depth of all existing utility lines (including water, gas, electric, fiber optic, and sewer) prior to construction. If any utility lines are located within the project limits, the Contractor shall provide appropriate protection and shall be responsible for any damage to such lines. A record of all utility lines located within the project limits shall be provided to the City of Midwest City.
- G6. The Contractor shall be responsible for the protection of all existing utility lines located within the project limits. The Contractor shall verify the location and depth of all existing utility lines (including water, gas, electric, fiber optic, and sewer) prior to construction. If any utility lines are located within the project limits, the Contractor shall provide appropriate protection and shall be responsible for any damage to such lines. A record of all utility lines located within the project limits shall be provided to the City of Midwest City.
- G7. The Contractor shall be responsible for the protection of all existing utility lines located within the project limits. The Contractor shall verify the location and depth of all existing utility lines (including water, gas, electric, fiber optic, and sewer) prior to construction. If any utility lines are located within the project limits, the Contractor shall provide appropriate protection and shall be responsible for any damage to such lines. A record of all utility lines located within the project limits shall be provided to the City of Midwest City.
- G8. The Contractor shall be responsible for the protection of all existing utility lines located within the project limits. The Contractor shall verify the location and depth of all existing utility lines (including water, gas, electric, fiber optic, and sewer) prior to construction. If any utility lines are located within the project limits, the Contractor shall provide appropriate protection and shall be responsible for any damage to such lines. A record of all utility lines located within the project limits shall be provided to the City of Midwest City.
- G9. The Contractor shall be responsible for the protection of all existing utility lines located within the project limits. The Contractor shall verify the location and depth of all existing utility lines (including water, gas, electric, fiber optic, and sewer) prior to construction. If any utility lines are located within the project limits, the Contractor shall provide appropriate protection and shall be responsible for any damage to such lines. A record of all utility lines located within the project limits shall be provided to the City of Midwest City.
- G10. The Contractor shall be responsible for the protection of all existing utility lines located within the project limits. The Contractor shall verify the location and depth of all existing utility lines (including water, gas, electric, fiber optic, and sewer) prior to construction. If any utility lines are located within the project limits, the Contractor shall provide appropriate protection and shall be responsible for any damage to such lines. A record of all utility lines located within the project limits shall be provided to the City of Midwest City.
- G11. The Contractor shall be responsible for the protection of all existing utility lines located within the project limits. The Contractor shall verify the location and depth of all existing utility lines (including water, gas, electric, fiber optic, and sewer) prior to construction. If any utility lines are located within the project limits, the Contractor shall provide appropriate protection and shall be responsible for any damage to such lines. A record of all utility lines located within the project limits shall be provided to the City of Midwest City.
- G12. The Contractor shall be responsible for the protection of all existing utility lines located within the project limits. The Contractor shall verify the location and depth of all existing utility lines (including water, gas, electric, fiber optic, and sewer) prior to construction. If any utility lines are located within the project limits, the Contractor shall provide appropriate protection and shall be responsible for any damage to such lines. A record of all utility lines located within the project limits shall be provided to the City of Midwest City.
- G13. The Contractor shall be responsible for the protection of all existing utility lines located within the project limits. The Contractor shall verify the location and depth of all existing utility lines (including water, gas, electric, fiber optic, and sewer) prior to construction. If any utility lines are located within the project limits, the Contractor shall provide appropriate protection and shall be responsible for any damage to such lines. A record of all utility lines located within the project limits shall be provided to the City of Midwest City.
- G14. The Contractor shall be responsible for the protection of all existing utility lines located within the project limits. The Contractor shall verify the location and depth of all existing utility lines (including water, gas, electric, fiber optic, and sewer) prior to construction. If any utility lines are located within the project limits, the Contractor shall provide appropriate protection and shall be responsible for any damage to such lines. A record of all utility lines located within the project limits shall be provided to the City of Midwest City.
- G15. The Contractor shall be responsible for the protection of all existing utility lines located within the project limits. The Contractor shall verify the location and depth of all existing utility lines (including water, gas, electric, fiber optic, and sewer) prior to construction. If any utility lines are located within the project limits, the Contractor shall provide appropriate protection and shall be responsible for any damage to such lines. A record of all utility lines located within the project limits shall be provided to the City of Midwest City.
- G16. The Contractor shall be responsible for the protection of all existing utility lines located within the project limits. The Contractor shall verify the location and depth of all existing utility lines (including water, gas, electric, fiber optic, and sewer) prior to construction. If any utility lines are located within the project limits, the Contractor shall provide appropriate protection and shall be responsible for any damage to such lines. A record of all utility lines located within the project limits shall be provided to the City of Midwest City.
- G17. The Contractor shall be responsible for the protection of all existing utility lines located within the project limits. The Contractor shall verify the location and depth of all existing utility lines (including water, gas, electric, fiber optic, and sewer) prior to construction. If any utility lines are located within the project limits, the Contractor shall provide appropriate protection and shall be responsible for any damage to such lines. A record of all utility lines located within the project limits shall be provided to the City of Midwest City.
- G18. The Contractor shall be responsible for the protection of all existing utility lines located within the project limits. The Contractor shall verify the location and depth of all existing utility lines (including water, gas, electric, fiber optic, and sewer) prior to construction. If any utility lines are located within the project limits, the Contractor shall provide appropriate protection and shall be responsible for any damage to such lines. A record of all utility lines located within the project limits shall be provided to the City of Midwest City.
- G19. The Contractor shall be responsible for the protection of all existing utility lines located within the project limits. The Contractor shall verify the location and depth of all existing utility lines (including water, gas, electric, fiber optic, and sewer) prior to construction. If any utility lines are located within the project limits, the Contractor shall provide appropriate protection and shall be responsible for any damage to such lines. A record of all utility lines located within the project limits shall be provided to the City of Midwest City.
- G20. The Contractor shall be responsible for the protection of all existing utility lines located within the project limits. The Contractor shall verify the location and depth of all existing utility lines (including water, gas, electric, fiber optic, and sewer) prior to construction. If any utility lines are located within the project limits, the Contractor shall provide appropriate protection and shall be responsible for any damage to such lines. A record of all utility lines located within the project limits shall be provided to the City of Midwest City.

SANITARY SEWER LINE MATERIALS AND CONSTRUCTION NOTES

- S91. All 4" pipe shall be installed in accordance with the requirement of Oklahoma Administrative Code (OAC) 252:656-5-4, depth 60" Water Pollution Control Administration Standard 252:656-5. All 4" pipe shall be installed in accordance with the requirement of Oklahoma Administrative Code (OAC) 252:656-5-4, depth 60".
- S92. Manhole depth shall be as shown on the plans. Manhole depth shall be as shown on the plans.
- S93. All 4" pipe shall be installed in accordance with the requirement of Oklahoma Administrative Code (OAC) 252:656-5-4, depth 60". All 4" pipe shall be installed in accordance with the requirement of Oklahoma Administrative Code (OAC) 252:656-5-4, depth 60".
- S94. All 4" pipe shall be installed in accordance with the requirement of Oklahoma Administrative Code (OAC) 252:656-5-4, depth 60". All 4" pipe shall be installed in accordance with the requirement of Oklahoma Administrative Code (OAC) 252:656-5-4, depth 60".
- S95. All 4" pipe shall be installed in accordance with the requirement of Oklahoma Administrative Code (OAC) 252:656-5-4, depth 60". All 4" pipe shall be installed in accordance with the requirement of Oklahoma Administrative Code (OAC) 252:656-5-4, depth 60".
- S96. All 4" pipe shall be installed in accordance with the requirement of Oklahoma Administrative Code (OAC) 252:656-5-4, depth 60". All 4" pipe shall be installed in accordance with the requirement of Oklahoma Administrative Code (OAC) 252:656-5-4, depth 60".
- S97. All 4" pipe shall be installed in accordance with the requirement of Oklahoma Administrative Code (OAC) 252:656-5-4, depth 60". All 4" pipe shall be installed in accordance with the requirement of Oklahoma Administrative Code (OAC) 252:656-5-4, depth 60".
- S98. All 4" pipe shall be installed in accordance with the requirement of Oklahoma Administrative Code (OAC) 252:656-5-4, depth 60". All 4" pipe shall be installed in accordance with the requirement of Oklahoma Administrative Code (OAC) 252:656-5-4, depth 60".
- S99. All 4" pipe shall be installed in accordance with the requirement of Oklahoma Administrative Code (OAC) 252:656-5-4, depth 60". All 4" pipe shall be installed in accordance with the requirement of Oklahoma Administrative Code (OAC) 252:656-5-4, depth 60".
- S100. All 4" pipe shall be installed in accordance with the requirement of Oklahoma Administrative Code (OAC) 252:656-5-4, depth 60". All 4" pipe shall be installed in accordance with the requirement of Oklahoma Administrative Code (OAC) 252:656-5-4, depth 60".

Sanitary Sewer Standards - Material - Manholes
In accordance with OAC 252:656-5-3(d), the use of bricks and/or concrete blocks in manhole construction is prohibited.

Sanitary Sewer Standards - Construction Standards - Sewer
In accordance with OAC 252:656-5-4(g), install metal liner wire with all non-metallic pipe and color code all underground installed pipe.

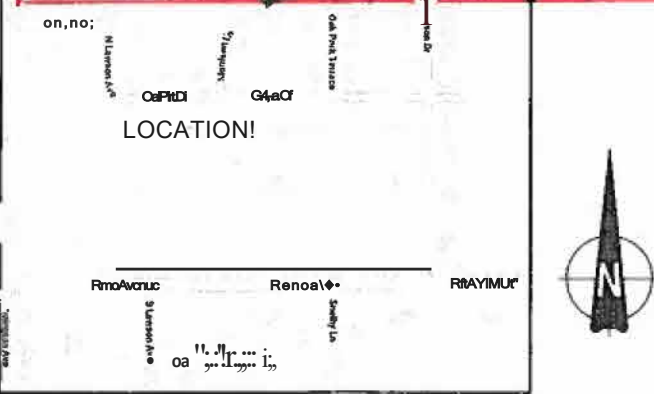

INDEX OF SHEETS	
SHEET #	DESCRIPTION
C-7.0	Title Sheet
C-7.1	Sanitary Sewer Plan
C-7.2	Sanitary Sewer Design Flows
SD-1	Sanitary Sewer Standard Details

UTILITY LOCATION NUMBER

840-5032
1-600-522-6543

This number is for information on the location of most underground utilities.

ff.
Oct 3 2018

am/FLOOR
REC'D

CITY/ACC:

11/11/18

COMMUNITY DEVELOPMENT DEPT.
ENGINEERING DIVISION

Sheet 1a of 1

11/28/2018 10:30 AM PLOT: 11-11-18-307

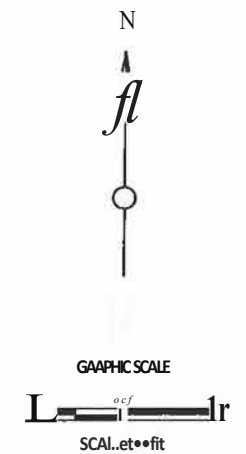
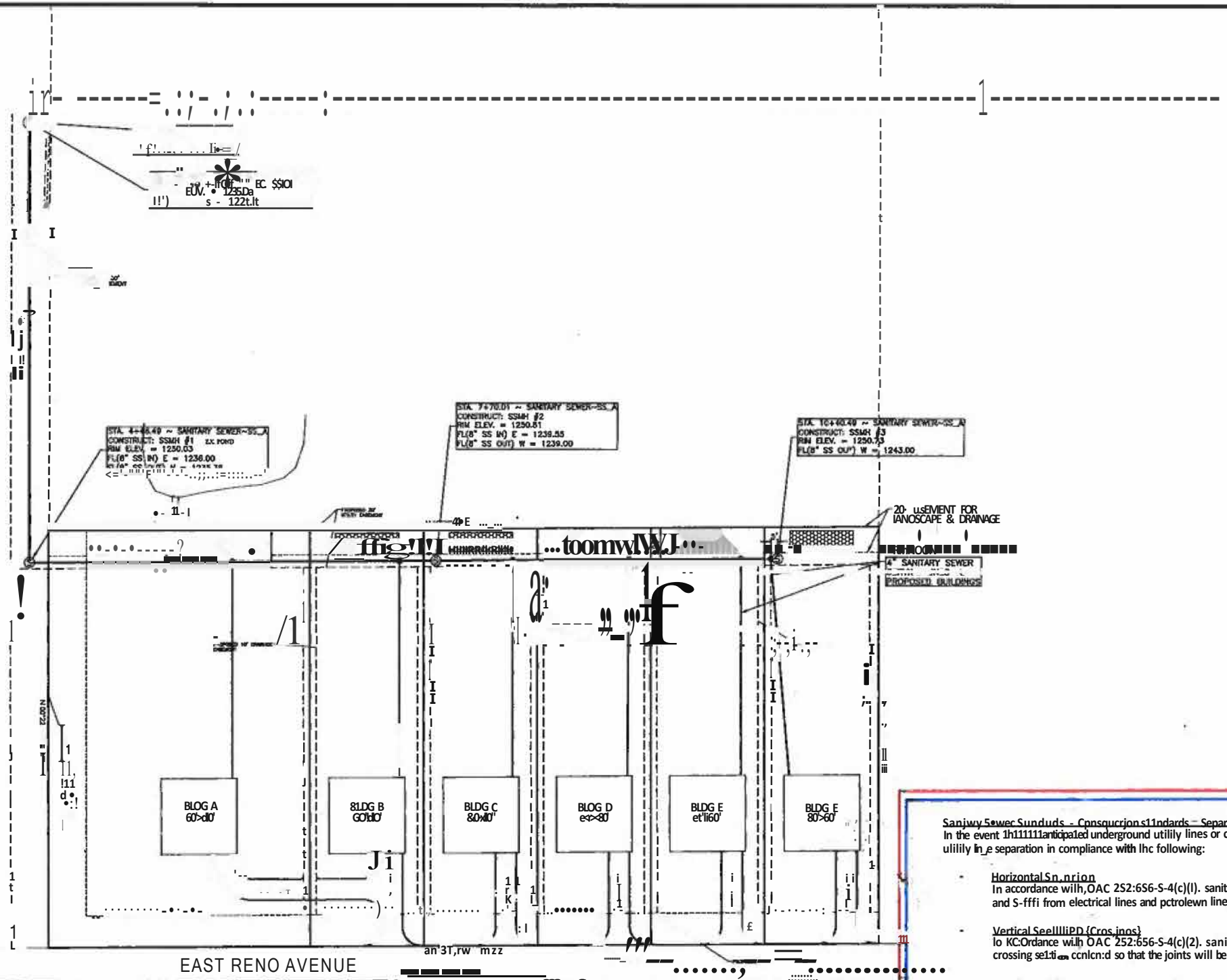

LEGEND	
@	EXISTING SAN. MANHOLE
---	EXISTING SAN. SEWER
---	PROPOSED SAN. SEWER
---	EXISTING WATERLINE
---	EXISTING WATER VALVE
---	PROPOSED WATERLINE
---	PROPOSED WATER VALVE
◆	PROPOSED FIRE HYDRANT
Ⓡ	PROPOSED SANITARY SEWER
---	FIRELANE

Sanitary Sewer Standards - Construction Standards - Separation
 In the event anticipated underground utility lines or conditions are encountered during construction, construct sewer line and other utility line separation in compliance with the following:

- Horizontal Separation**
 In accordance with OAC 252:656-5-4(c)(1), sanitary sewers must be at least 10 feet from any existing or proposed water main, and separated from electrical lines and petroleum lines.
- Vertical Separation (Crossings)**
 In accordance with OAC 252:656-5-4(c)(2), sanitary sewers must cross at least 24 inches above or below water mains, and the crossing shall be constructed so that the joints will be as far as possible from the water mains.
- Special Condition**
 In accordance with OAC 252:656-5-4(c)(3), when it is impossible to obtain proper horizontal and vertical separation as stipulated above, design and construct the sewer line equal to water pipe, and pressure-test it to assure water tightness of joint adjacent to the water line prior to backfilling. Sewer lines shall not be laid in water line trenches. Sec OAC 252:626-19-2(B)(C).

STATE OF OKLAHOMA
 DEPARTMENT OF ENVIRONMENTAL QUALITY
APPROVED

DEC 28 2018
 Rocky W. Chen, P.E.
 Water Quality Division

Robert Walker
 Construction Permitting Section

CDH
E.D. HILL, L.L.C.
 510 COLCORD DRIVE OKLAHOMA CITY, OK 73102
 TELE (405) 232-2208 FAX (405) 232-2229
 CERTIFICATE OF AUTHORIZATION 105
 EXPIRES JUNE 20, 2018
 CA# 105

ISSUE DATE	10/01/2018
SCALE	HORIZONTAL: 1"=30'
CRAWN BY	NM
APPROVED BY	NM
OWNER No.	1000
	C-6.0

10225 E RENO SEWER
 CITY OF MIDWEST, OKLAHOMA COUNTY, OK
SANITARY SEWER PLAN
ENGINEERING, INC.
 Civil Engineers
 3201 FOERDWE
 hwt, TX 3719 USA
 FAX (512) 717-4111 m (512) 717-4100
 1 EXPIRES-10.

HORIZONTAL SCALE: 1" = 40'
VERTICAL SCALE: 1" = 10'

SANITARY SEWER~SS_A: STA. 0+00.00 ~ 11+00.00

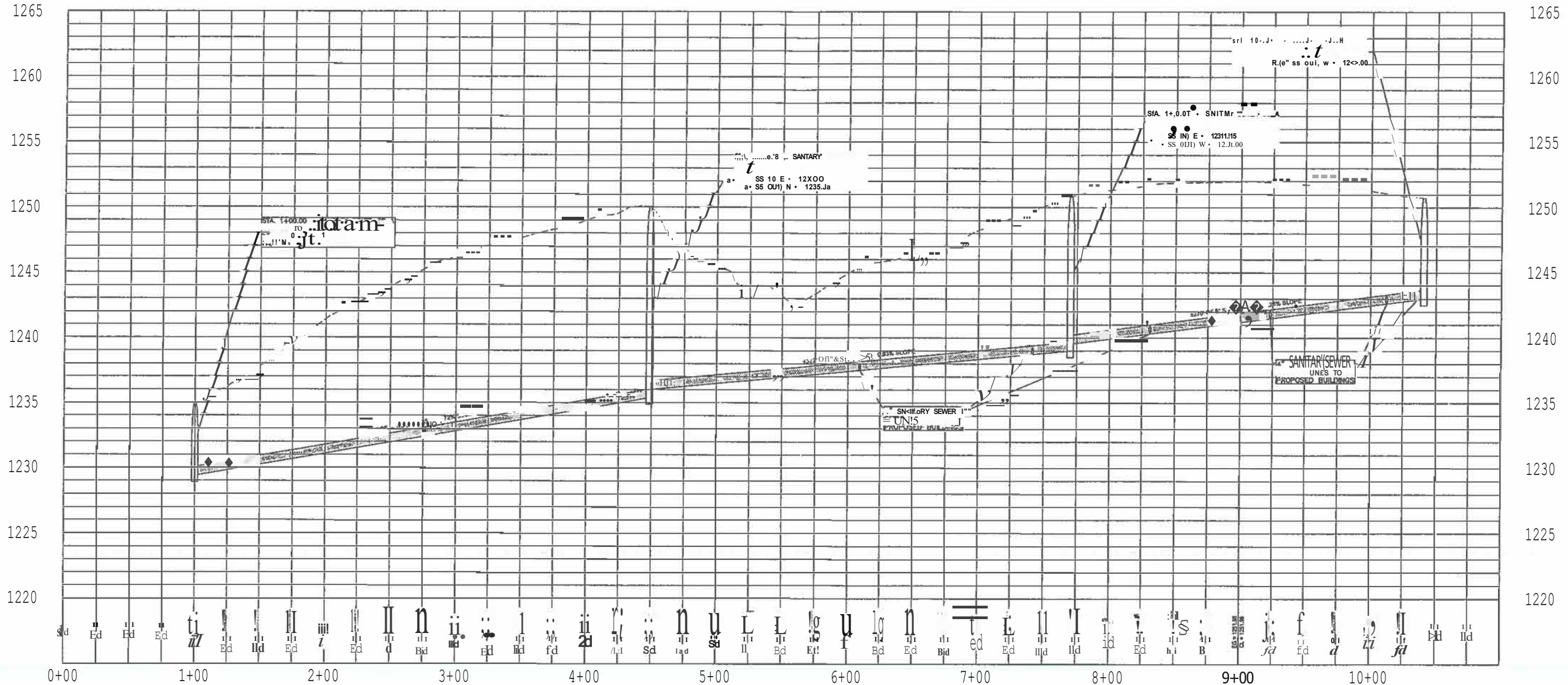

STATE OF OKLAHOMA
DEPARTMENT OF ENVIRONMENTAL QUALITY
APPROVED

DEC 28 2018

Rocky W. Chen, P.E.
Water Quality Division

Robert B. Walker
Construction Printing Section

CDH
E.D. HILL, L.L.C.
510 COLCORD DRIVE OKLAHOMA CITY, OK 73102
TELE (405) 232-2208 FAX (405) 232-2229
CERTIFICATE OF AUTHORIZATION 105
EXPIRES JUNE 20, 2018
CA# 105

ISSUED DATE:	TBO
SCJW:	
HORIZ: 1" = 40'	
DRAWN BY:	NM
APPROVED BY:	NM
OHR JOB NO.:	180770
SHEET:	C-6.1

10225 E RENO SEWER
CITY OF MUSTANG, OKLAHOMA COUNTY, OK
SANITARY SEWER PROFILE

ENGINEERING, INC.
Civil Engineers
12011 ECHERIRVE
1719-TX75062-3719US-
FAX(912)717-0118.(1721717-0118)
CA# 115 EXPIRES 06/20/11

PLOT: 11/16/2018 11:07:36
 PLOT: 11/16/2018 11:07:36

E. RENO SEWER! SANITARY SEWER DESIGN FLOWS																				
SANITARY	COLLECTION		RECEIVING		SANITARY SEWER										DESIGN		REMARKS			
	LINE	INLET	OUTLET	CONDUIT	NO. OF	UNIT	PERSONS	ADDITIONAL	INLET	INLET	INLET	INLET	INLET	INLET	INLET	INLET		INLET	INLET	INLET
	1	2	S		7		0330		1111	0.000	2	120						20	22	
&S-A	NMHR																			
	EXISTING	EXISTING					2310.0		247.5											SEE T&E W. S&A

STATE OF OKLAHOMA
DEPARTMENT OF ENVIRONMENTAL QUALITY
APPROVED

DEC 28 2018

Rocky W. Chen, P.E.
Water Quality Division

Robert Swatker
Construction Permitting Section

GENERAL NOTES

1. Castings shall conform to the ASTM Specifications for Gray-Iron Castings, Serial specification A 48-29
2. Each cover is placed in any position in its oval form, the slope play in any direction shall not exceed one-eighth (1/8") inch.
3. No wording or marking of any kind, other than those shown, on the plan shall be furnished on finished castings.

SCHEDULE OF THICKNESS

THE DIAMETER	THICKNESS
8"	1'-8"
10"	1'-10"
12"	2'-1"
14"	2'-4"
16"	2'-8"
18"	3'-0"
20"	3'-4"
24"	3'-7"

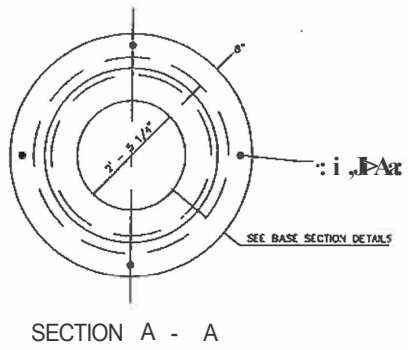
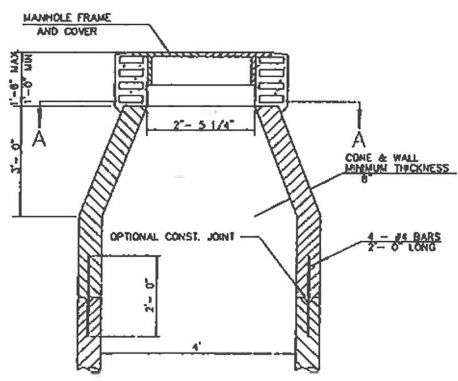

MANHOLE DETAIL

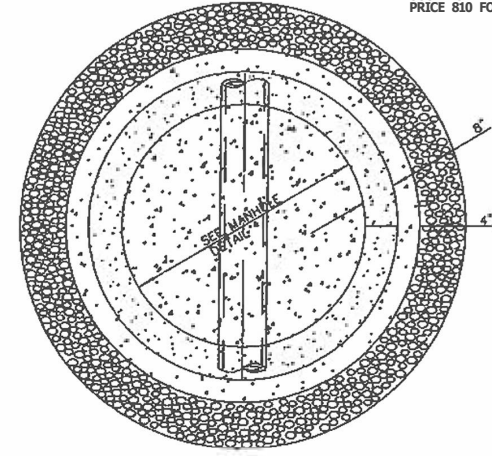
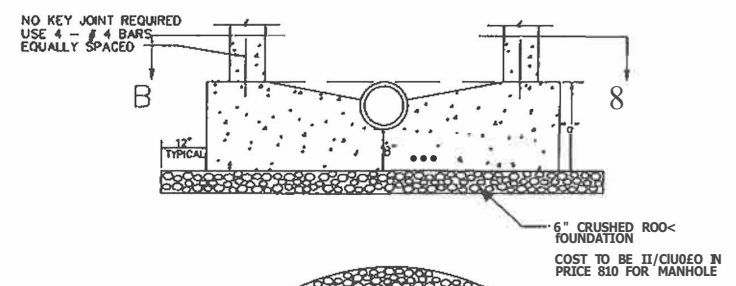

STANDARD DETAIL FOR MANHOLE BASE SECTION

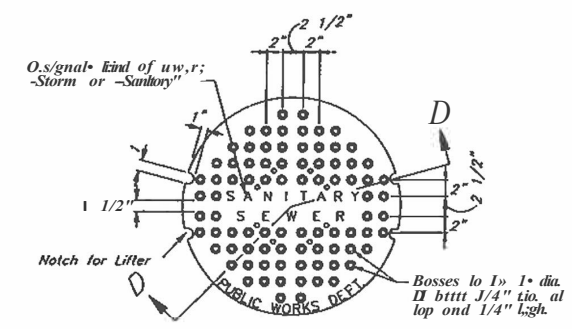

PLAN OF TOP
PLAN OF UNDERSIDE

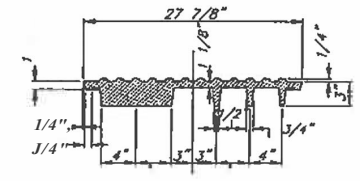

SECTION D - D
STANDARD COVER

NOTE:
1. ALL ARE SHALL BE SMOOTH SURF
2. NEOPRENE FROM BENTONITE COMPOUND
EIGHT SHU MET AM C-21



STATE OF OKLAHOMA
DEPARTMENT OF ENVIRONMENTAL QUALITY

APPROVED

DEC 28 2018

Rocky W. Chen, P.E.
Water Quality Division

Robert B. Walker
Construction, (C) Engineering Section

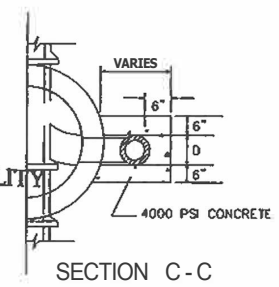

MANHOLE DROP CONNECTION

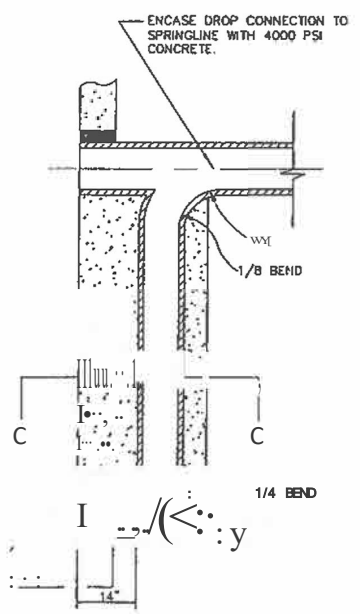

TYPICAL TRENCH SECTION

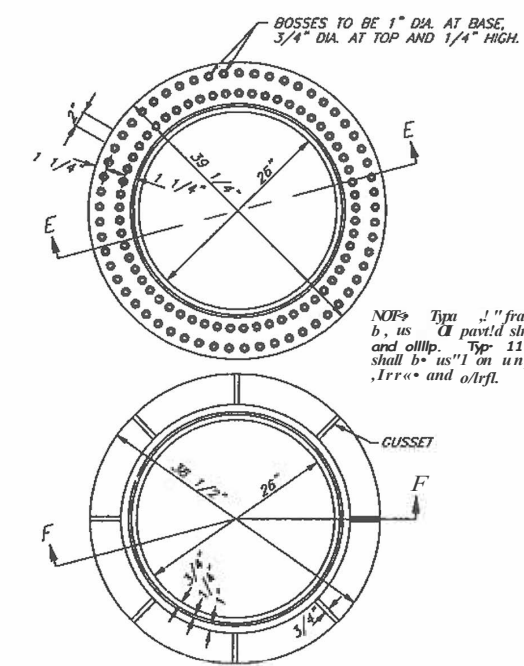

STANDARD
MANHOLE FRAMES

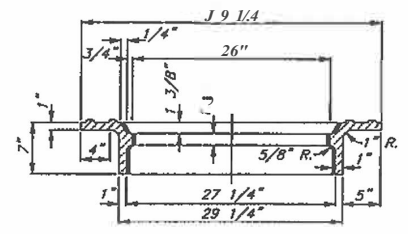

SECTION E - E
STANDARD FRAME

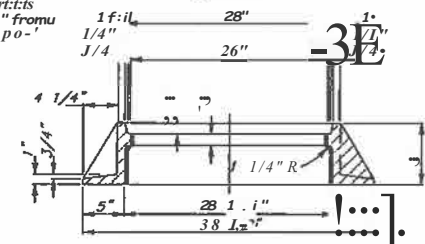

SECTION F - F
STANDARD FRAME

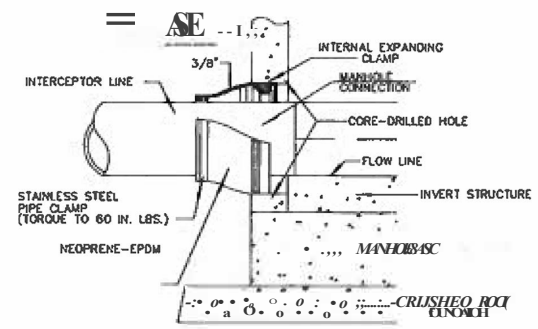

MANHOLE-PIPE CONNECTION

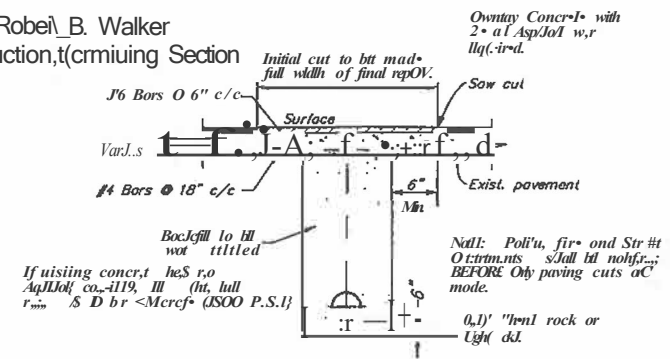

STREET CROSSING

MIDWEST CITY ENGINEERING DEPARTMENT

STANDARD
SEWER LINE
DETAILS

PROJECT-NO SHEET-NO

COUNTY

OATE-STAMP



The City of
MIDWEST CITY
COMMUNITY DEVELOPMENT DEPARTMENT -
ENGINEERING DIVISION

Billy Harless, Community Development Director
Patrick Menefee, P.E., City Engineer

ENGINEERING DIVISION
Patrick Menefee, City Engineer
CURRENT PLANNING DIVISION
Kellie Gilles, Manager
COMPREHENSIVE PLANNING
, Comprehensive Planner
BUILDING INSPECTION DIVISION
Christine Brakefield, Building Official
GIS DIVISION
Greg Hakman, GIS Coordinator

To: Honorable Mayor and Council

From: Patrick Menefee, P.E., City Engineer

Date: February 12th, 2019

Subject: Discussion and consideration of the acceptance of and making a matter of record Permit No. WL000055180734 from the State Department of Environmental Quality for the S.E. 29th Street Water Line Extension Project (Oak Avenue to Post Road), Midwest City, Oklahoma.

Permit No. WL000055180610734 is for the construction of 3375 L.F. of twelve inch (12"), 70 L.F. of six inch (6"), and 20 L.F. of four inch (4") water line serve the S.E. 29th Street Water Line Extension Project (Oak Avenue to Post Road), Midwest City, Oklahoma.

Staff recommends acceptance as this is consistent with past policy.

Patrick Menefee, P.E.
City Engineer



SCOTT A. THOMPSON
Executive Director

OKLAHOMA DEPARTMENT OF ENVIRONMENTAL QUALITY

MARY FALLIN
Governor

January 9, 2019

J. Guy Henson, City Manager
City of Midwest City
100 N. Midwest Blvd.
Midwest City, Oklahoma 73110

Re: Permit No.: WL000055180734
S. E. 29th Street
Water Line Extension Project
(Oak Ave to Post Road)
PWSID No.: 1020806

Dear Mr. Henson:

Enclosed is Permit No.: WL000055180734 for the construction of approximately 20 L. F. of four (4) inch, 70 L. F. of six (6) inch, and 3,375 L. F. of twelve (12) inch water lines and appurtenances to serve the City of Midwest City S. E. 29th Street Water Line Extension Project (Oak Ave to Post Road), Oklahoma County, Oklahoma.

The project authorized by this permit should be constructed in accordance with the plans approved by this Department on January 9, 2019. Any deviations from the approved plans and specifications affecting capacity, flow, or operation of units must be approved, in writing, by the Department before changes are made.

Receipt of this permit should be noted in the minutes of the next regular meeting of the City of Midwest City, after which it should be made a matter of permanent record.

We are returning one (1) set of the approved plans to you and retaining one (1) set for our files.

Respectfully,

A handwritten signature in blue ink, appearing to be 'R. Walker'.

r) IMP--

Robert B. Walker
Construction Permit Section
Water Quality Division

RBW/RC/ag

Enclosure

c: Oklahoma City DEQ Office
Travis Mensik, R. S., Regional Manager, DEQ
Brandon Bundy, P. E., City Engineer, City of Midwest City





SCOTT A. THOMPSON
Executive Director

OKLAHOMA DEPARTMENT OF ENVIRONMENTAL QUALITY

MARY FALUN
Governor

PERMIT NO.: WL000055180734

WATERLINES

PWSID NO.: 1020806

PERMIT TO CONSTRUCT

January 9, 2019

Pursuant to O.S. 27A 2-6-304, the City of Midwest City is hereby granted this Tier I Permit to construct approximately 20 L F. of four (4) inch, 70 L F. of six (6) inch, and 3,375 L F. of twelve (12) inch water lines and appurtenances to serve the City of Midwest City S. E 29th Street Water Line Extension Project (Oak Ave to Post Road), located in part of S-1/2, 5-1/2 of Section 12, T-11-N, R-2-W, L M., Oklahoma County, Oklahoma, in accordance with the plans approved on January 9, 2019.

By acceptance of this permit, the permittee agrees to operate and maintain the facility in accordance with the Public Water Supply Operation rules (OAC 252:631) and to comply with the State Certification laws, Title 59, Section 1101-1116 0.5. and the rules and regulations adopted thereunder regarding the requirements for certified operators.

This permit is issued subject to the following provisions and conditions.

- 1) This water line design is deemed adequate to provide the 2015 International Fire Code minimum fire hydrant fire flow based on submitted City Master Hydraulic Analysis Model information. The fire flow provided is 2,750 gpm.
- 2) That the recipient of the permit is responsible that the project receives supervision and inspection by competent and qualified personnel.
- 3) That construction of all phases of the project will be started within one year of the date of approval, or the phases not under construction will be resubmitted for approval as a new project.
- 4) That no significant information necessary for a proper evaluation of the project has been omitted, or invalid information has been presented in applying for the permit.
- 5) That the Oklahoma Department of Environmental Quality shall be kept informed on occurrences which may affect the eventual performance of the works or that will unduly delay the progress of the project.
- 6) That before placing this facility into service, at least two samples of the water, taken on different days, shall be tested for bacteria to show that it is safe for drinking purposes.
- 7) That any deviations from approved plans or specifications affecting capacity, flow or operation of units must be approved by the Department before any such deviations are made in the construction of this project.

Page 1 of 2





SCOTT A. THOMPSON
Executive Director

OKLAHOMA DEPARTMENT OF ENVIRONMENTAL QUALITY

MARY FALLIN
Governor

PERMIT NO.: WL000055180734

WATERLINES

PWSID NO.: 1020806

PERMIT TO CONSTRUCT

- 8) That the recipient of the permit is responsible for the continued operation and maintenance of these facilities in accordance with rules and regulations adopted by the Environmental Quality Board, and that this Department will be notified in writing of any sale or transfer of ownership of these facilities.
- 9) The issuance of this permit does not relieve the responsible parties of any obligations or liabilities which the permittee may be under pursuant to prior enforcement action taken by the Department.
- 10) That the permittee is required to inform the developer/builder that a DEQ Storm Water Construction Permit is required for a construction site that will disturb one (1) acre or more in accordance with OPDES, 27A O.S. Section 2-6-201 ~~et seq.~~ For information or a copy of the GENERAL PERMIT (OKR10) FOR STORM WATER DISCHARGES FROM CONSTRUCTION ACTIVITIES, Notice of Intent (NOI) form, Notice of Termination (NOT) form, or guidance on preparation of a Pollution Prevention Plan, contact the Storm Water Unit of the Water Quality Division at P.O. Box 1677, Oklahoma City, OK 73101-1677 or by phone at (405) 702-8100.
- 11) That any notations or changes recorded on the official set of plans and specifications in the Oklahoma Department of Environmental Quality files shall be part of the plans as approved.
- 12) That whenever plastic pipe is approved and used for potable water, it shall bear the seal of the National Sanitation Foundation and meet the appropriate commercial standards.
- 13) That when it is impossible to obtain proper horizontal and vertical separation as stipulated in Public Water Supply Construction Standards OAC 252:626-19-2(h)(1) and OAC 252:626-19-2(h)(2), respectively, the sewer shall be designed and constructed equal to water pipe, and shall be pressure tested to the highest pressure obtainable under the most severe head conditions of the collection system prior to backfilling.

Failure to appeal the conditions of this permit in writing within 30 days from the date of issue will constitute acceptance of the permit and all conditions and provisions.

Rocky Chen, P.E., Engineering Manager, Construction Permit Section
Water Quality Division





The City of
MIDWEST CITY
 COMMUNITY DEVELOPMENT DEPARTMENT -
 ENGINEERING DIVISION

Billy Harless, Community Development Director
 Patrick Menefee, P.E., City Engineer

ENGINEERING DIVISION
 Patrick Menefee, City Engineer
 CURRENT PLANNING DIVISION
 Kellie Gilles, Manager
 COMPREHENSIVE PLANNING
 , Comprehensive Planner
 BUILDING INSPECTION DIVISION
 Christine Brakefield, Building Official
 GIS DIVISION
 Greg Hakman, GIS Coordinator

To: Honorable Mayor and Council

From: Patrick Menefee, P.E., City Engineer

Date: February 12th, 2019

Subject: Discussion and consideration of approving the following sidewalk projects for potential construction in calendar year 2019 utilizing the Sidewalk Fee and Sidewalk/Trails Fee Funds.

At the January 22nd, 2019 Sidewalk Committee Meeting, the Committee was updated on the following sidewalk projects listed below and the state of the sidewalk fund balance for the calendar year 2019:

Project #	Location	Description	Linear Feet of Sidewalk
1	NE 10 th St – Douglas to Post	Under Installation	
2	Post Rd – Reno to NE 10 th	Engineering	5280
3	S.E. 29 th St – Douglas to Post	Engineering	5280
4	S.E. 29 th St – Post East	Engineering	5280
5	S Post Road – S E 10 th St to SE 15 th	Concrete plus ramp	1,875
6	W. Fairchild – Air Depot to Jarman Middle School	Concrete only	1,650
7	Adair – Harr Drive to Rose State College	Concrete only (plus right of way)	1,070
8	Felix – SE 15 th St to E Nothrup	Concrete/ ramps	800

The attached Sidewalk Project Status Map shows the proposed sidewalk projects recommended for construction as well as the status of the arterial sidewalk projects for your review.

Approval of sidewalk projects is at the discretion of the Council.

Patrick Menefee, P.E.
 City Engineer

Attachment

Notice of the Midwest City Sidewalk Committee meeting was filed with the Midwest City Clerk and a copy of the agenda for the meeting was posted in the lobby of City Hall at least 24 hours in advance of the meeting.

**MINUTES OF MIDWEST CITY
SIDEWALK COMMITTEE
MEETING
January 22nd, 2019, 5:30 PM**

The meeting of the Midwest City Sidewalk Committee was held in the Community Development Conference Room, Midwest City, Oklahoma County, Oklahoma, on January 22nd, 2019 at 5:00 p.m., with the following members:

Española Bowen, Chair
Sean Reed, Vice Chair
Matt Dukes, Mayor

Staff present: Patrick Menefee, City Engineer
Brandon Bundy, Assistant City Engineer

The meeting was called to order by the Chairman Dawkins.

A. MINUTES

Motion was made by Sean Reed and seconded by Matt Dukes to approve the minutes of the January 23rd, 2018 meeting. Voting aye: all present Nay: none. Motion carried.

B. DISCUSSION ITEMS

1. Discussion and consideration of financial report of Sidewalk Fee Fund and the Sidewalk/Trails Sales Tax Revenue Fund.

Patrick Menefee referred to the memo included in the agenda packet. Reported was the fund balance, what was constructed since last year's meeting, and the anticipated projects upcoming this budget year.

Since the item was information only, no action was taken on this item.

2. Discussion and consideration of a status report of Midwest City's Trail Projects funded through ODOT.

Patrick Menefee referred to the memo included in the agenda packet. Reported on the anticipated projects upcoming this budget year.

Since the item was information only, no action was taken on this item.

3. Discussion and consideration of a status report of the Midwest City ADA Transition Plan.

Patrick Menefee referred to the memo included in the agenda packet. Reported was the fund balance, what was constructed since last year's meeting, and the anticipated projects upcoming this budget year.

Sidewalk Committee Minutes

Since the item was information only, no action was taken on this item.

4. Discussion and consideration of recommending sidewalk projects for construction for calendar year 2018 utilizing the Sidewalk Fee Fund and the Sidewalk/Trails Sales Tax Revenue.

The memo was reviewed from the agenda packet. Current funds were reviewed. It was recommended to continue to following the project list as funds become available.

Discussion continued among the committee members.

Motion was made by Sean Reed, seconded by Matt Dukes, to recommend to the City Council there be no new sidewalk projects this year due to low Sidewalk Fund and Sidewalk /Trails Sales Tax Revenue Fund Fees being available. Voting aye: all present. Nay: none. Motion carried.

C. NEW BUSINESS / PUBLIC DISCUSSION

No further items were discussed.

D. ADJOURNMENT

There being no further business, a motion was made by Sean Reed, seconded by Matt Dukes, to adjourn the meeting. Voting aye: all present. Nay: none. Motion carried. Meeting adjourned at 5:45 p.m.

Espaniola Bowen, Chair

Sidewalk Project Status

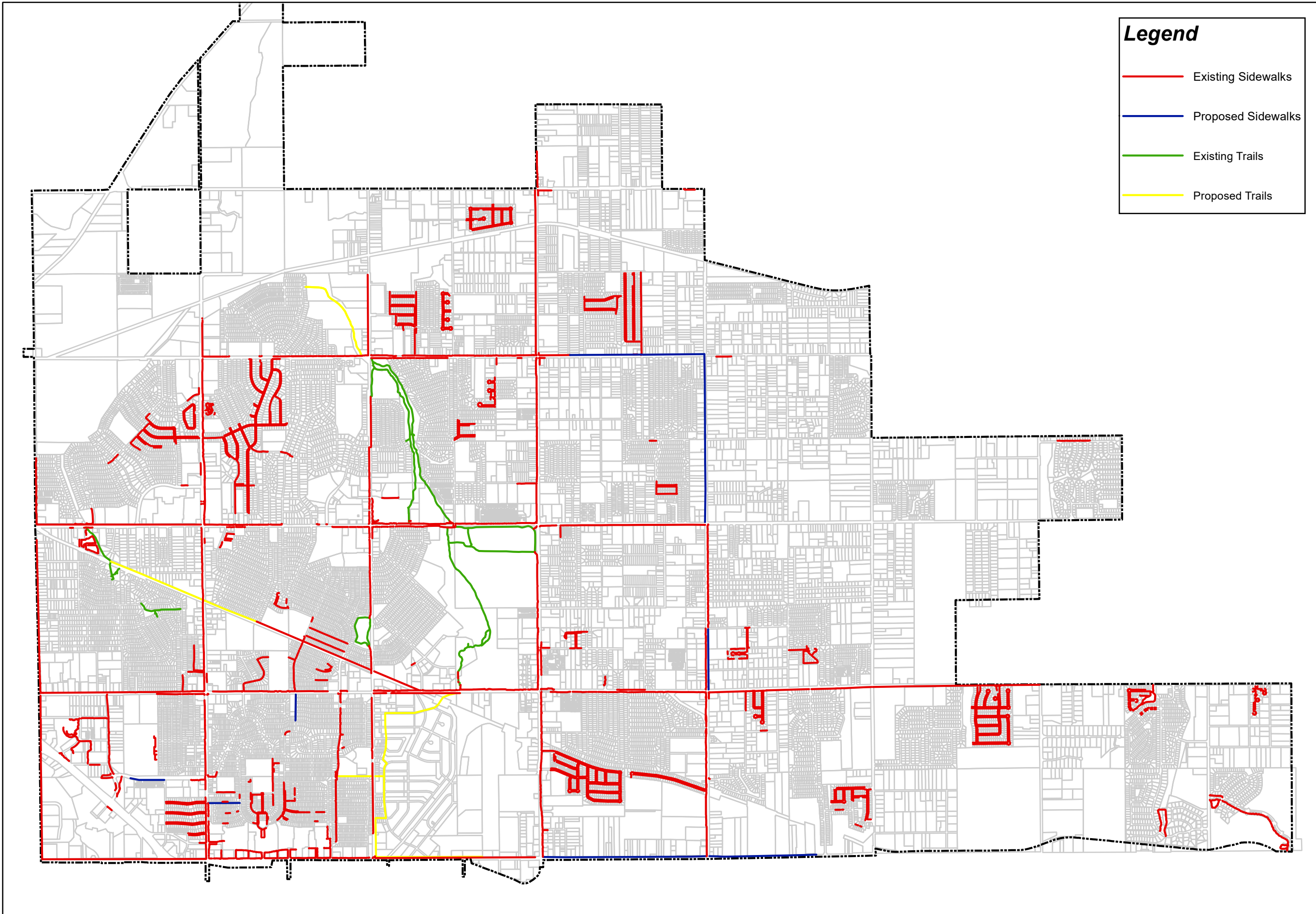

Legend

- Existing Sidewalks
- Proposed Sidewalks
- Existing Trails
- Proposed Trails



1 in = 2,917 ft

when printed actual size
on 11"x17" paper

DISCLAIMER

This map is a general information public resource. The City of Midwest City makes no warranty, representation or guarantee as to the content, accuracy, timeliness or completeness of any of the information provided on this map. Any party's use or reliance on this map, or any information on it, is at that party's own risk and without liability to the City of Midwest City, its officials or its employees for any discrepancies, errors or variances that may exist.



The City of
MIDWEST CITY
COMMUNITY DEVELOPMENT DEPARTMENT -
ENGINEERING DIVISION

Billy Harless, Community Development Director
Patrick Menefee, P.E., City Engineer

ENGINEERING DIVISION
Patrick Menefee, City Engineer
CURRENT PLANNING DIVISION
Kellie Gilles, Manager
COMPREHENSIVE PLANNING
, Comprehensive Planner
BUILDING INSPECTION DIVISION
Christine Brakefield, Building Official
GIS DIVISION
Greg Hakman, GIS Coordinator

TO : Honorable Mayor and Council

FROM : Patrick Menefee, P.E., City Engineer

DATE : February 12th, 2019

SUBJECT : Discussion and consideration of entering into a project agreement for Federal-aid Project Number STP-155E(919)EH, State Job Number 28817(04), with the Oklahoma Department of Transportation to receive federal funds in the amount of \$600,000.00 to construct the Midwest City Mid-America Park Trail.

The federal funds are needed in connection with the proposed construction of the Mid-America Park Trail. The preliminary estimate for the total project cost is \$790,000. This project will be funded by 76% federal funds, 24% local match. The city will be required to contribute \$190,000 to ODOT to cover construction costs as required with the 24% local match provision.

Staff recommends approval.

Patrick Menefee, P.E.,
City Engineer

Attachment

**PROJECT AGREEMENT
BETWEEN
THE OKLAHOMA DEPARTMENT OF TRANSPORTATION
AND
THE CITY OF MIDWEST CITY**

This Project Agreement ("Agreement") is made by and between the Oklahoma Department of Transportation, hereinafter referred to as the "Department," and the City of MIDWEST CITY, hereinafter referred to as the "City," which may be referred to collectively as the "Parties," for the following intents and purposes and subject to the following terms and conditions, to wit:

Project Type	Div	County	JP No	Project No.	Work Type	Description
ENHANCEMENT	04	OKLAHOMA	28817(04)	STP-155E (919) EH	ENHANCEMENT	MIDWEST CITY MID-AMERICA TRAIL

WITNESSETH

WHEREAS, the Department is charged under the laws of the State of Oklahoma with construction and maintenance of State Highways; and,

WHEREAS, the Department is, by terms of agreements with the Federal Highway Administration, responsible for the management and construction of certain federally funded projects within the corporate limits of cities within the State of Oklahoma; and,

WHEREAS, the City has been identified as the beneficiary and sub-recipient of such federally funded project; and,

WHEREAS, receipt of the benefits of this project will require that the City assume certain financial responsibilities; and,

WHEREAS, the City is a municipal corporation created and existing under the constitution and laws of the State of Oklahoma; and,

WHEREAS, the laws and constitution of the State of Oklahoma impose financial restrictions on the City and its ability to ensure financial obligations; and,

WHEREAS, the Parties hereto recognize those financial limitations and agree that the financial obligations assumed by the City, by the terms of this Agreement, are enforceable only to the extent as may be allowed by law or as may be determined by a court of competent jurisdiction; and,

WHEREAS, it is understood that, by virtue of the Article 10, Section 26 of the Oklahoma Constitution, the payment of City funds in the future will be limited to appropriations and available funds in the then current City fiscal year.

NOW THEREFORE, subject to the limitations hereinbefore described, the Department and the City do agree as follows:

1. The City requested that certain street improvements be approved by the Oklahoma Transportation Commission, as were previously programmed by the City and **described as follows:**

Project Type	Div	County	JP No	Project No.	Work Type	Description
ENHANCEMENT	04	OKLAHOMA	28817(04)	STP-155E(919)EH	ENHANCEMENT	MIDWEST CITY MIO.AMERICA TRAIL

2. The City shall prepare, or cause to be prepared, plans for construction of this federal-aid project and agrees that all construction shall be in conformance with the furnished plans, which are incorporated with and made part of this Agreement.
3. The City agrees that the furnished plans at the time of bidding, are at a minimum, in compliance with the current Oklahoma Department of Transportation Standard Specifications for Highway Construction.
4.
 - A. The City shall be responsible for furnishing all right-of-way for this federal-aid project in compliance with all applicable laws, federal regulations, and guidelines established by the USDOT's FHWA's Office of Real Estate Services, including 42 USC, Chapter 6l (The Uniform Act) and 49 CFR Part 24, (Uniform Relocation Assistance and Real Property Acquisition For Federal and Federally Assisted Programs), as well as applicable State Statutes, Oklahoma Administrative Codes, and Department Policy; free and clear of all obstructions and encroachments; and that the City shall, at its sole expense, maintain the project after construction.
 - B. The City shall keep all permanent right-of-way shown on said plans free from any encroachment and take timely action to effect the removal of any encroachments upon notification by the Department, including all necessary legal action when required.
 - C. The City shall acquire all right-of-way, if any, be responsible for the total costs for removing and relocating outdoor advertising signs and for the relocation assistance payments to persons displaced by reason of the acquisition of right-of-way and be responsible for the removal or relocation of all utility lines on public or private rights-of-way to accommodate the construction of this project, and comply with these additional requirements:
 1. Transmit copies of the instruments, including all deeds and easements, to the Department prior to the advertisement of bids for construction.
 2. Comply with the provisions of 42 U.S.C.A. § 4601-4655 and 23 U.S.C.A. § 323 (as amended) and, further comply with 49 C.F.R. Part 24 in the acquisition of all necessary right-of-way and relocation of all displacees.

3. Convey title to the State of Oklahoma on all tracts of land acquired in the name of the City if the project is located on the State Highway System.

D. If the acquisition of right-of-way for this project causes the displacement of any person, business or non-profit organization, the City will provide and be responsible for the Relocation Assistance Program and for all cost associated with the relocation assistance payments. The Department will supply a list of approved service providers qualified to administer the Relocation Assistance Program. The City agrees to employ a service provider from the approved list and comply with all applicable rules, regulations, statutes, policies and procedures of both the United States and the State of Oklahoma. Before any relocation assistance payments are made, (if applicable), all files with parcels requiring relocation shall be audited by the Department. The Department shall be notified in writing within seven (7) days of the date of the offer to the property owner on any parcel which will require relocation assistance. Written notifications of offers to acquire shall be addressed to Project Manager, Right-of-Way Division, Oklahoma Department of Transportation, 200 N. E. 21st Street, Oklahoma City, Oklahoma 73105.

5. The City agrees to the location of the subject project and agrees to adopt the final plans for said project as the official plans of the City for the streets, boulevards, arterial highways and/or other improvements contained therein; and further, *the* City affirmatively states that it has or shall fully and completely examine the plans and shall hereby warrant to the Department, the City's complete satisfaction with these plans and the fitness of the plans to construct aforesaid project.
6. A. The City certifies that the project design plans shall comply, and *the* project when completed will comply, with the requirements of the Americans with Disabilities Act (ADA) of 1990 (42 U.S.C. §§ 12101 - 12213), 49 CFR Parts 27, 37 and 38 and 28 CFR parts 35 and 36. The City shall be exclusively responsible for integrated ADA compliance planning for all City streets, sidewalks and other facilities provided for public administration, use and accommodation, which is required of recipients and sub-recipients by 49 CFR § 27.11. State highways continued through corporate limits of the City shall be included in the City's comprehensive compliance plans.

R The CITY agrees to comply with the **The Americans with Disabilities Act Non-Discrimination Clause** which is incorporated into this agreement as the attached ADA Exhibit.

7. The Parties hereto agree to comply with all applicable laws and regulations meeting Environmental Protection Agency (EPA) requirements for pollution prevention, including discharges from storm water runoff on this project. The Department shall require the contractor who may be awarded the project to meet all Oklahoma Department of Environmental Quality (ODEQ) requirements for storm water runoff on this project. It is agreed that the project plans and specifications, required schedules for accomplishing the temporary and permanent erosion control work, the Storm Water Management Plan (SWMP) sheet and appropriate U.S. Geological Survey (USGS) topographic map contained in the plans constitute the SWMP for the project described previously in this document. Further, if required, the Department shall require the contractor to file a Notice of Intent (NOi) for storm

water discharges associated with construction activity under the Oklahoma Pollutant Discharges Elimination System (OPDES) General Permit with ODEQ, which authorizes the storm water discharges associated with construction activity from the construction site, and to develop, if required, a Storm Water Pollution Prevention Plan (SWPPP).

8. The City agrees that prior to the Department's advertising of the project for bids (as to that part of the project lying within the present corporate limits) it will:
- (a) Grant to the Department and its contractors, the right-of-entry to all existing streets, alleys, and City owned property when required, and other rights-of-way shown on said plans.
 - (b) Remove at its own expense, or cause the removal of, all encroachments on existing streets as shown on said plans, including all signs, buildings, porches, awnings, porticos, fences, gasoline pumps and islands, and any other such private installations.
 - (c) To prohibit parking on that portion of the project within the corporate limits of the City, except as may be indicated in the plans or hereafter approved by agreement with the Department. The City further agrees not to install, or permit to be installed, any signs, signals or markings not in conformance with the standards approved by the Federal Highway Administration and Manual on Uniform Traffic Control Devices (MUTCD).
 - (d) Comply with the Department's standards for construction of driveway entrances from private property to the highway, in accordance with the Department's manual entitled "Policy on Driveway Regulation for Oklahoma Highways", Rev. 5/96, 69 O.S. (2001) § 1210.
 - (e) Maintain all right of way acquired for the construction of this project, as shown on said plans, in a manner consistent with applicable statutes, codes, ordinances and regulations of the Department and the State of Oklahoma.
- (Q The City shall have the authority pursuant to 69 O.S. 2001 § 1001 and 69 O.S. 2001 § 1004 to sell any lands, or interest therein, which were acquired for highway purposes as long as such sale is conducted in accordance with the above cited statutes. Prior written approval by the Chief, Right-of-Way Division for the Department shall be required before any sale is made.
9. The City further agrees and warrants to the Department that, subsequent to the construction of said project, the City will:
- a Erect, maintain and operate traffic control devices, including signals, signs and pavement markings only in accordance with 47 O.S. 2011 §§ 15-104- 15-106, and subject to agreement of the Department:
 - 1) In the event that any traffic signal installed hereunder is no longer needed for the purposes designated herein, then the traffic signal installed hereunder shall not be removed by the City to any other point other than that which is approved by the Department prior to such removal.

- 2) In the event there is no mutually agreed location for the reinstallation, the City will assume complete ownership of the equipment following removal if the installation is ten (10) years old or older. If the installation is less than ten (10) years old and:
 - a) In the event City desires total ownership of the equipment, the City shall reimburse the Department the original federal funding percentage share for the original equipment cost only, amortized for a ten (10) year service life, interest ignored, and assuming straight line depreciation.
 - b) In the event the City does not desire total ownership of the equipment, the City shall sell the equipment at public auction to the highest bidder. The City shall reimburse the Department the original federal funding percentage share of the proceeds of such sale.
- b) Subject to agreement with the Department, regulate and control traffic on said project, including but not limited to, the speed of vehicles, parking, stopping and turns only in accordance with 47 O.S. 2011 §§ 15-104- 15-106, and to make no changes in the provisions thereof without the approval of the Department. It shall be the responsibility of the City to notify the Department of any changes necessary to ensure safety to the traveling public.
- c) Maintain all drainage systems and facilities constructed, installed, modified or repaired in conjunction with this project or as may be otherwise necessary to ensure proper drainage for road surfaces constructed under the terms of this Agreement.
- d) Maintain all curbs and driveways abutting road surfaces constructed under the terms of this Agreement and all sidewalks adjacent thereto.
- e) Maintain all right-of-way areas adjacent to road surfaces, including erosion control and period mowing of vegetation, in a manner consistent with applicable codes, ordinances and regulations.
- f) Make ample provision annually for proper maintenance of items heretofore delineated as the responsibility of the City, including the provision of competent personnel and adequate equipment, and specifically, to provide all required special maintenance of the project during the critical period immediately following constructions.
- g) Keep all permanent right-of-way shown on said plans free from any encroachment and take immediate action to effect the removal of any encroachments upon notification by the Department.
- h) For any portion of the project encompassed under this agreement that is part of the State Highway System, the City shall maintain all that part of said project within the corporate limits of the City between the gutter lines and the right-of-way lines, and if no gutter exists, between the shoulder lines and the right-of-way lines, including storm

sewers, all underground facilities, curbs and mowing, all in accordance with 69 O.S. Supp. 1994 §901 and all other applicable law.

- i On limited access highways where county roads or city streets extend over or under the highway or public roads are constructed on state rights-of-way but there is no immediate ingress and egress from the highway, responsibility shall be as follows:
 - (1) The public roads as defined in OAC 730:35-1-2 shall be maintained by the city or county and shall be included in their roadway mileage inventory.
 - (2) Where county roads or city streets extend over the highway, the roadway, approaches and bridge surfaces, including the deck, shall be maintained by the city or county. The approach guardrail, bridge structure, and highest clearance posting on the structure shall be maintained by the Department.
 - (3) Where county roads or city streets extend under the highway, the roadway approaches and advance signing shall be maintained by the city or county. The Department shall maintain the approach guardrail, bridge structure and surface, and the height clearance posting on the structure.
10. The City further agrees and warrants to the Department concerning any sign and highway facility lighting included as part of this project:
- a. The City will, upon notice from the Department Engineer, provide at its own expense all required electrical energy necessary for all preliminary and operational tests of the highway lighting facilities.
 - b. Upon completion of the construction of said project, the City will be responsible for the maintenance and cost of operation of these highway lighting facilities, including all appurtenances thereto and including the sign lighting facilities.
 - c. It is specifically understood and agreed that the highway lighting and sign lighting facilities specified hereunder shall be continuously operated during the hours of darkness, between sunset and sunrise, and shall not be altered, removed or be allowed to cease operation without the mutual written consent of the Department and the City.
 - d. The City agrees to provide, on a periodic schedule, an inspection, cleaning and re-lamping maintenance program to assure the maximum efficiency of the highway lighting facilities.
 - e. In the event that the highway lighting facilities installed hereunder are no longer needed for the purposes designated herein, then the highway lighting facilities installed hereunder shall not be removed by the City to any point other than which is approved by the Department prior to such removal.

- f In the event there is no mutually agreed location for reinstallation, the City will assume complete ownership of the equipment following removal if the installation is twenty (20) years old or older. If the installation is less than twenty years old and:
- 1) In the event the City desires total ownership of the equipment, the City shall reimburse the Department the original federal funding percentage share of the original equipment costs only, amortized for a twenty (20) year service life, interest ignored, and assuming straight line depreciation.
 - 2) In the event the City does not desire total ownership of the equipment, the City shall sell the equipment at public auction to the highest bidder. The City shall reimburse the Department the original federal funding percentage share of the proceeds of such sale.
11. The City agrees, affirms and warrants to the Department that the City will be responsible, during the period of construction, for any repairs or maintenance to the approved detour route or any other street which may be required as a result of additional traffic.
12. The City agrees to comply with Title VI of the Civil Rights Act of 1964, 78 O.S. § 252.42, 42 U.S.C. §§ 200d et seq., and all requirements imposed by or pursuant to 49 CFR, Part 21, "Nondiscrimination in Federally Assisted Programs of the Department of Transportation - Effectuation of Title VI of the Civil Rights Act of 1964."
13. The City agrees that it will, by resolution, duly authorize the execution of this Agreement by the proper officials and attach copies of such resolution to this Agreement.
14. To the extent permitted by the ***Oklahoma Governmental Tort Claims Act***, Title 51 Oklahoma Statutes, Sections 151 *et seq.* and by Oklahoma Constitution Article 10, section 26 and as otherwise permitted by law, the City shall indemnify and save harmless the Department, its officers and employees, and shall process and defend at its own expense all claims, demands, or suits whether in law or equity brought against the City or the Department arising from the City's execution, performance, or failure to perform, and provisions of this agreement or alleged negligence in the location, design, construction, operation, or maintenance of a portion of the City Street System within the corporate limits of the City. Provided, nothing herein shall require the City to reimburse the Department for damages arising out of bodily injury to persons or damage to property caused by or resulting from the sole negligence of the Department. When any alleged act, omission, negligence, or misconduct may be subject to the limitations, exemptions, or defenses which may be raised under the ***Oklahoma Governmental Tort Claims Act***, 51 O.S. § 151 et seq., all such limitations, exemptions, and defenses shall be available to and may be asserted by City. No liability shall attach to the Department except as expressly provided herein.

15. Based on an estimated total construction cost plus construction inspection cost of Seven-Hundred-Ninety-Thousand-Dollars (\$790,000.00), it is agreed the project referenced above will be financed as follows:
- Federal STP funds shall be used to finance 76% of the federally participating construction costs of Six-Hundred-Thousand-Dollars (\$600,000.00). Federal participation is capped at Six-Hundred-Thousand-Dollars (\$600,000.00).
 - City funds provided by the City shall be provided to finance the balance of the eligible participating project construction costs, estimated at One-Hundred-Ninety-Thousand-Dollars (\$190,000.00). The CITY shall also provide 100% of any federally non-participating costs, estimated at Zero-Dollars (\$0.00). Total City funds are currently estimated at One-Hundred-Ninety-Thousand-Dollars (\$190,000.00). The estimated City funds shall be placed on deposit with the DEPARTMENT upon execution of this agreement and receipt of the Department's invoice, prior to advertising the project for bid.
16. a) It is understood by the City and the Department that the funding participation stipulated herein may be altered due to bid prices, construction supervision costs and federally non-participating costs incurred during construction.
- b) The DEPARTMENT, using its own forces or the services of others, will supervise and inspect all work performed by the construction contractor and will provide such engineering, inspection and testing services as may be required to ensure that the construction of the project is accomplished in accordance with the approved PS&E. Actual supervision and inspection costs shall be charged to the project and financed as described in PARAGRAPH 15 of this agreement.
- c) The City will be responsible for payment of estimated local funding prior to advertising the project for bid. Upon final acceptance of this project, the amount of federal funds and the amount previously deposited by the City will be deducted from the total cost and a refund will be made by the Department to the City or additional funding will be requested from the City. The City agrees to make arrangements for payment of any Department invoice within 45 days of receipt.
17. It is understood by the City that only those DEPARTMENT administered funding sources specified in Paragraph 15 of this agreement shall be made available for the financing of this project. All other costs are the responsibility of the CITY. No STATE funds are allocated to this project.
18. Upon approval of this Agreement and the plans, specifications and estimates by the City, Department and the Federal Highway Administration, if applicable, the Department shall agree to advertise and let the contract for this project in the usual and customary legal manner. It is agreed that the project herein described is proposed to be financed as previously set forth, and that this Agreement, all plans, specifications, estimates of costs, acceptance of work, payments and procedures in general hereunder are subject in all things at all times to all federal laws, regulations, orders and approvals as may be applicable hereto.

19. The Department agrees to construct said project in strict accordance with the plans furnished and approved by the City, provided that upon consultation with and agreement by the City, the Department shall have the right to make such changes in the plans and specifications as are necessary for the proper construction of the project. The Department shall provide competent supervision at all times that the work is in progress. The City shall have inspectors on the project site as the City determines necessary to ensure construction of the project to the satisfaction of the City and shall have representatives available for consultation with the Department representatives to cooperate fully to the end of obtaining work strictly in accordance with the City's approved plans and specifications.
20. The City agrees that it will intervene as a party defendant in all actions where a contractor may allege delay due to failure of the City to accomplish timely utility relocations, site conditions which are not represented on the plans or plan errors which impact on project constructability, whether in the District Court or in an alternative dispute resolution forum, will defend all such actions and will pay all damages relating to delay as may be assessed by such court or alternative dispute resolution forum against the City for its adjudged failure.
21. Failure by the City to fulfill its responsibilities under this Agreement will disqualify the City from future participation in any Federal-aid project. Federal funds are to be withheld until such time as the deficiencies in regulations have been corrected or the improvements to be constructed under this Agreement are brought to a satisfactory condition of maintenance.
22. It is further specifically agreed between the City and the Department that the project will be built in accordance with the plans and specifications, and upon final acceptance by the City and the Department of this project, the City does hereby accept full, complete and total responsibility for maintenance of this project as provided in this Agreement. The City does not waive any rights against any contractor(s) with respects to defects, hidden or otherwise, in materials or workmanship. The City does not, pursuant to this provision or any other provision in this Agreement, waive its sovereign immunity or any exemption from, exception to or limitation of liability as provided in the Governmental Tort Claims Act.
23. The Secretary of the Department may terminate this Agreement in whole or, from time to time, in part whenever:
 - a. The requisite federal funding becomes unavailable through failure of appropriation or otherwise.
 - b. The contractor is prevented from proceeding with the work as a direct result of an Executive Order of the President with respect to the prosecution of war or in the interest of national defense or an Executive Order of the President or Governor of the State with respect to the preservation of energy resources.
 - c. The contractor is prevented from proceeding with the work by reason of a preliminary, special or permanent restraining order of a court of competent jurisdiction where the issuance of such order is primarily caused by the acts or omissions of persons or agencies other than the contractor.

- d. The Secretary determines that such termination is in the best interest of the State.

REMAINDER OF PAGE INTENTIONALLY BLANK

IN WITNESS WHEREOF, the Deputy Director of the Department of Transportation, pursuant to authority vested in him by the State Transportation Commission, has hereunto subscribed his name as Deputy Director of the Department of Transportation and the City has executed same pursuant to authority prescribed by law for the City.

The City, _____ on this __ of _____, 2019, and the Department on the __ day of _____, 2019.

The City of Midwest City,
an Oklahoma Municipal Corporation

Mayor

(SEAL)

ATTEST:

City Clerk

Approved as to Form and Legality:

City Attorney

STATE OF OKLAHOMA
DEPARTMENT OF TRANSPORTATION

Recommended for Approval

Local Government Division Manager

Director of Capital Programs

APPROVED AS TO FORM
AND LEGALITY

APPROVED

General Counsel

Deputy Director

OKLAHOMA DEPARTMENT OF TRANSPORTATION

INVOICE

Make check PAYABLE, and MAIL TO:

**Oklahoma Department of Transportation
 Comptroller Division
 200 N.E. 21st Street
 Oklahoma City, Oklahoma 73105-3204**

To: The City of Midwest City

Department Invoice No 28817(04)
 January 23, 2019

Description - Explanation of Charge	Quantity	Price Each	Total
Due Date: <u>Upon Receipt</u>			
Project Number: STP-155E(919)EH Job Number: 28817(04)			
Total Estimated Cost including Inspection Cost:			\$ 790,000.00
Less Federal Share			(\$ 600,000.00)
Less Sponsor Initial Deposit			(\$ 0,00.00)
Local Share Due			<hr/> \$ 190,000.00
Accounting Use Only		Invoice Total	\$ 190,000.00

Distribution:

City
 Remit with Payment
 Division Project File
 Comptroller Division



The City of
MIDWEST CITY
COMMUNITY DEVELOPMENT DEPARTMENT-
ENGINEERING DIVISION

Billy Harless, Community Development Director
Patrick Menefee, P.E., City Engineer

ENGINEERING DIVISION
Patrick Menefee, City Engineer
CURRENT PLANNING DIVISION
Kellie Gilles, Manager
COMPREHENSIVE PLANNING
• Comprehensive Planner
BUILDING INSPECTION DIVISION
Christine Brakefield, Building Official
GJS DIVISION
Greg Hakman, GIS Coordinator

TO: Honorable Mayor and Council

FROM: Patrick Menefee, P.E., City Engineer

DATE: February 12th, 2019

SUBJECT : Discussion and consideration of entering into a project agreement for Federal-aid Project Number STP-255B(461)AG, State Job Number 31548(04), with the Oklahoma Department of Transportation to receive federal funds in the amount of \$2,984,000.00 to construct the Midwest City Reconstruction of S.E. 29th Street from Midwest Boulevard to Douglas Boulevard including the S.E. 29th Street Midwest Boulevard intersection but not the Douglas Boulevard S.E. 29th Street intersection.

The federal funds are needed in connection with the proposed construction of the Mid-America Park Trail. The preliminary estimate for the total project cost is \$3,730,000. This project will be funded by 80% federal funds, 20% local match. The city will be required to contribute \$746,000 to ODOT to cover construction costs as required with the 20% local match provision.

Staff recommends approval.

Patrick Menefee, P.E.,
City Engineer

Attachment

**PROJECT AGREEMENT
BETWEEN
THE OKLAHOMA DEPARTMENT OF TRANSPORTATION
AND
THE CITY OF MIDWEST CITY**

This Project Agreement (“Agreement”) is made by and between the Oklahoma Department of Transportation, hereinafter referred to as the “Department,” and the City of MIDWEST CITY, hereinafter referred to as the “City,” which may be referred to collectively as the “Parties,” for the following intents and purposes and subject to the following terms and conditions, to wit:

Project Type	DIV	County	JP No	Project No.	Work Type	Description
CITY STREET	04	OKLAHOMA	31548(04)	STP -255B (461) AG	RECONSTRUCT - NO ADDED LANES	MIDWEST CITY RECONST SE 29TH FR MIDWEST BLVD TO DOUGLAS BLVD INC SE 29TH/ MIDWEST BLVD INTERSEC BUT NOT SE 29TH & DOUGLAS.

WITNESSETH

WHEREAS, the Department is charged under the laws of the State of Oklahoma with construction and maintenance of State Highways; and,

WHEREAS, the Department is, by terms of agreements with the Federal Highway Administration, responsible for the management and construction of certain federally funded projects within the corporate limits of cities within the State of Oklahoma; and,

WHEREAS, the City has been identified as the beneficiary and sub-recipient of such federally funded project; and,

WHEREAS, receipt of the benefits of this project will require that the City assume certain financial responsibilities; and,

WHEREAS, the City is a municipal corporation created and existing under the constitution and laws of the State of Oklahoma; and,

WHEREAS, the laws and constitution of the State of Oklahoma impose financial restrictions on the City and its ability to ensure financial obligations; and,

WHEREAS, the Parties hereto recognize those financial limitations and agree that the financial obligations assumed by the City, by the terms of this Agreement, are enforceable only to the extent as may be allowed by law or as may be determined by a court of competent jurisdiction; and,

WHEREAS, it is understood that, by virtue of the Article 10, Section 26 of the Oklahoma Constitution, the payment of City funds in the future will be limited to appropriations and available funds in the then current City fiscal year.

NOW THEREFORE, subject to the limitations hereinbefore described, the Department and the City do agree as follows:

1. The City requested that certain street improvements be approved by the Oklahoma Transportation Commission, as were previously programmed by the City and **described as follows:**

Project Type	DIV	County	JP No	Project No.	Work Type	Description
CITVSTREET	04	OKLAHOMA	31548(04)	STP-255B (461)AG	RECONSTRUCT - NO ADDED LANES	MIDWEST CIV RECONST SE 29TH RR MIDWEST BLVD TO DOUGLAS BLVD INC SE 29TH/ MIDWEST BLVD INTERSEC BUT NOT SE 29TH & DOUGLAS.

2. The City shall prepare, or cause to be prepared, plans for construction of this federal-aid project and agrees that all construction shall be in conformance with the furnished plans, which are incorporated with and made part of this Agreement.
3. The City agrees that the furnished plans at the time of bidding, are at a minimum, in compliance with the current Oklahoma Department of Transportation Standard Specifications for Highway Construction.
4.
 - A. The City shall be responsible for furnishing all right-of-way for this federal-aid project in compliance with all applicable laws, federal regulations, and guidelines established by the USDOT's FHWA's Office of Real Estate Services, including 42 USC, Chapter 61 (The Uniform Act) and 49 CFR Part 24, (Uniform Relocation Assistance and Real Property Acquisition For Federal and Federally Assisted Programs), as well as applicable State Statutes, Oklahoma Administrative Codes, and Department Policy; free and clear of all obstructions and encroachments; and that the City shall, at its sole expense, maintain the project after construction.
 - B. The City shall keep all permanent right-of-way shown on said plans free from any encroachment and take timely action to effect the removal of any encroachments upon notification by the Department, including all necessary legal action when required.
 - C. The City shall acquire all right-of-way, if any, be responsible for the total costs for removing and relocating outdoor advertising signs and for the relocation assistance payments to persons displaced by reason of the acquisition of right-of-way and be responsible for the removal or relocation of all utility lines on public or private rights-of-way to accommodate the construction of this project, and comply with these additional requirements:
 1. Transmit copies of the instruments, including all deeds and easements, to the Department prior to the advertisement of bids for construction.
 2. Comply with the provisions of 42 U.S.C.A. § 4601-4655 and 23 U.S.C.A. § 323 (as amended) and, further comply with 49 C.F.R. Part 24 in the acquisition of all necessary right-of-way and relocation of all displacees.

3. Convey title to the State of Oklahoma on all tracts of land acquired in the name of the City if the project is located on the State Highway System.

D. If the acquisition of right-of-way for this project causes the displacement of any person, business or non-profit organization, the City will provide and be responsible for the Relocation Assistance Program and for all cost associated with the relocation assistance payments. The Department will supply a list of approved service providers qualified to administer the Relocation Assistance Program. The City agrees to employ a service provider from the approved list and comply with all applicable rules, regulations, statutes, policies and procedures of both the United States and the State of Oklahoma. Before any relocation assistance payments are made, (if applicable), all files with parcels requiring relocation shall be audited by the Department. The Department shall be notified in writing within seven (7) days of the date of the offer to the property owner on any parcel which will require relocation assistance. Written notifications of offers to acquire shall be addressed to Project Manager, Right-of-Way Division, Oklahoma Department of Transportation, 200 N. E. 21st Street, Oklahoma City, Oklahoma 73105.

5. The City agrees to the location of the subject project and agrees to adopt the final plans for said project as the official plans of the City for the streets, boulevards, arterial highways and/or other improvements contained therein; and further, the City affirmatively states that it has or shall fully and completely examine the plans and shall hereby warrant to the Department, the City's complete satisfaction with these plans and the fitness of the plans to construct aforesaid project.
6. A. The City certifies that the project design plans shall comply, and the project when completed will comply, with the requirements of the Americans with Disabilities Act (ADA) of 1990 (42 U.S.C. §§ 12101 - 12213), 49 CFR Parts 27, 37 and 38 and 28 CFR parts 35 and 36. The City shall be exclusively responsible for integrated ADA compliance planning for all City streets, sidewalks and other facilities provided for public administration, use and accommodation, which is required of recipients and sub-recipients by 49 CFR § 27.11. State highways continued through corporate limits of the City shall be included in the City's comprehensive compliance plans.

B. The CITY agrees to comply with the **The Americans with Disabilities Act Non-Discrimination Clause** which is incorporated into this agreement as the attached ADA Exhibit.
7. The Parties hereto agree to comply with all applicable laws and regulations meeting Environmental Protection Agency (EPA) requirements for pollution prevention, including discharges from storm water runoff on this project. The Department shall require the contractor who may be awarded the project to meet all Oklahoma Department of Environmental Quality (ODEQ) requirements for storm water runoff on this project. It is agreed that the project plans and specifications, required schedules for accomplishing the temporary and permanent erosion control work, the Storm Water Management Plan (SWMP) sheet and appropriate U.S. Geological Survey (USGS) topographic map contained in the plans constitute the SWMP for the project described previously in this document. Further, if required, the Department shall require the contractor to file a Notice of Intent (NOi) for storm

water discharges associated with construction activity under the Oklahoma Pollutant Discharges Elimination System (OPDES) General Permit with ODEQ, which authorizes the storm water discharges associated with construction activity from the construction site, and to develop, if required, a Storm Water Pollution Prevention Plan (SWPPP).

8. The City agrees that prior to the Department's advertising of the project for bids (as to that part of the project lying within the present corporate limits) it will:
- (a) Grant to the Department and its contractors, the right-of-entry to all existing streets, alleys, and City owned property when required, and other rights-of-way shown on said plans.
 - (b) Remove at its own expense, or cause the removal of, all encroachments on existing streets as shown on said plans, including all signs, buildings, porches, awnings, porticos, fences, gasoline pumps and islands, and any other such private installations.
 - (c) To prohibit parking on that portion of the project within the corporate limits of the City, except as may be indicated in the plans or hereafter approved by agreement with the Department. The City further agrees not to install, or permit to be installed, any signs, signals or markings not in conformance with the standards approved by the Federal Highway Administration and Manual on Uniform Traffic Control Devices (MUTCD).
 - (d) Comply with the Department's standards for construction of driveway entrances from private property to the highway, in accordance with the Department's manual entitled "Policy on Driveway Regulation for Oklahoma Highways", Rev. 5/96, 69 O.S. (2001) § 1210.
 - (e) Maintain all right of way acquired for the construction of this project, as shown on said plans, in a manner consistent with applicable statutes, codes, ordinances and regulations of the Department and the State of Oklahoma.
 - (f) The City shall have the authority pursuant to 69 O.S. 2001 § 1001 and 69 O.S. 2001 § 1004 to sell any lands, or interest therein, which were acquired for highway purposes as long as such sale is conducted in accordance with the above cited statutes. Prior written approval by the Chief, Right-of-Way Division for the Department shall be required before any sale is made.
9. The City further agrees and warrants to the Department that, subsequent to the construction of said project, the City will:
- a. Erect, maintain and operate traffic control devices, including signals, signs and pavement markings only in accordance with 47 O.S. 2011 §§ 15-104- 15-106, and subject to agreement of the Department:
 - l) In the event that any traffic signal installed hereunder is no longer needed for the purposes designated herein, then the traffic signal installed hereunder shall not be removed by the City to any other point other than that which is approved by the Department prior to such removal.

- 2) In the event there is no mutually agreed location for the reinstallation, the City will assume complete ownership of the equipment following removal if the installation is ten (10) years old or older. If the installation is less than ten (10) years old and:
 - a) In the event City desires total ownership of the equipment, the City shall reimburse the Department the original federal funding percentage share for the original equipment cost only, amortized for a ten (10) year service life, interest ignored, and assuming straight line depreciation.
 - b) In the event the City does not desire total ownership of the equipment, the City shall sell the equipment at public auction to the highest bidder. The City shall reimburse the Department the original federal funding percentage share of the proceeds of such sale.
- b) Subject to agreement with the Department, regulate and control traffic on said project, including but not limited to, the speed of vehicles, parking, stopping and turns only in accordance with 47 O.S. 2011 §§ 15-104- 15-106, and to make no changes in the provisions thereof without the approval of the Department. It shall be the responsibility of the City to notify the Department of any changes necessary to ensure safety to the traveling public.
- c) Maintain all drainage systems and facilities constructed, installed, modified or repaired in conjunction with this project or as may be otherwise necessary to ensure proper drainage for road surfaces constructed under the terms of this Agreement.
- d) Maintain all curbs and driveways abutting road surfaces constructed under the terms of this Agreement and all sidewalks adjacent thereto.
- e) Maintain all right-of-way areas adjacent to road surfaces, including erosion control and period mowing of vegetation, in a manner consistent with applicable codes, ordinances and regulations.
- f) Make ample provision annually for proper maintenance of items heretofore delineated as the responsibility of the City, including the provision of competent personnel and adequate equipment, and specifically, to provide all required special maintenance of the project during the critical period immediately following constructions.
- g) Keep all permanent right-of-way shown on said plans free from any encroachment and take immediate action to effect the removal of any encroachments upon notification by the Department.
- h) For any portion of the project encompassed under this agreement that is part of the State Highway System, the City shall maintain all that part of said project within the corporate limits of the City between the gutter lines and the right-of-way lines, and if no gutter exists, between the shoulder lines and the right-of-way lines, including storm

sewers, all underground facilities, curbs and mowing, all in accordance with 69 O.S. Supp. 1994 §901 and all other applicable law.

t On limited access highways where county roads or city streets extend over or under the highway or public roads are constructed on state rights-of-way but there is no immediate ingress and egress from the highway, responsibility shall be as follows:

(1) The public roads as defined in OAC 730:35-1-2 shall be maintained by the city or county and shall be included in their roadway mileage inventory.

(2) Where county roads or city streets extend over the highway, the roadway, approaches and bridge surfaces, including the deck, shall be maintained by the city or county. The approach guardrail, bridge structure, and highest clearance posting on the structure shall be maintained by the Department.

(3) Where county roads or city streets extend under the highway, the roadway approaches and advance signing shall be maintained by the city or county. The Department shall maintain the approach guardrail, bridge structure and surface, and the height clearance posting on the structure.

10. The City further agrees and warrants to the Department concerning any sign and highway facility lighting included as part of this project:

- a. The City will, upon notice from the Department Engineer, provide at its own expense all required electrical energy necessary for all preliminary and operational tests of the highway lighting facilities.
- b. Upon completion of the construction of said project, the City will be responsible for the maintenance and cost of operation of these highway lighting facilities, including all appurtenances thereto and including the sign lighting facilities.
- c. It is specifically understood and agreed that the highway lighting and sign lighting facilities specified hereunder shall be continuously operated during the hours of darkness, between sunset and sunrise, and shall not be altered, removed or be allowed to cease operation without the mutual written consent of the Department and the City.
- d. The City agrees to provide, on a periodic schedule, an inspection, cleaning and re-lamping maintenance program to assure the maximum efficiency of the highway lighting facilities.
- e. In the event that the highway lighting facilities installed hereunder are no longer needed for the purposes designated herein, then the highway lighting facilities installed hereunder shall not be removed by the City to any point other than which is approved by the Department prior to such removal.

- f In the event there is no mutually agreed location for reinstallation, the City will assume complete ownership of the equipment following removal if the installation is twenty (20) years old or older. If the installation is less than twenty years old and:
- 1) In the event the City desires total ownership of the equipment, the City shall reimburse the Department the original federal funding percentage share of the original equipment costs only, amortized for a twenty (20) year service life, interest ignored, and assuming straight line depreciation.
 - 2) In the event the City does not desire total ownership of the equipment, the City shall sell the equipment at public auction to the highest bidder. The City shall reimburse the Department the original federal funding percentage share of the proceeds of such sale.
11. The City agrees, affirms and warrants to the Department that the City will be responsible, during the period of construction, for any repairs or maintenance to the approved detour route or any other street which may be required as a result of additional traffic.
12. The City agrees to comply with Title VI of the Civil Rights Act of 1964, 78 O.S. § 252.42, 42 U.S.C. §§ 200d et seq., and all requirements imposed by or pursuant to 49 CFR, Part 21, "Nondiscrimination in Federally Assisted Programs of the Department of Transportation - Effectuation of Title VI of the Civil Rights Act of 1964."
13. The City agrees that it will, by resolution, duly authorize the execution of this Agreement by the proper officials and attach copies of such resolution to this Agreement.
14. To the extent permitted by the ***Oklahoma Governmental Tort Claims Act***, Title 51 Oklahoma Statutes, Sections 151 *et seq.* and by Oklahoma Constitution Article 10, section 26 and as otherwise permitted by law, the City shall indemnify and save harmless the Department, its officers and employees, and shall process and defend at its own expense all claims, demands, or suits whether in law or equity brought against the City or the Department arising from the City's execution, performance, or failure to perform, and provisions of this agreement or alleged negligence in the location, design, construction, operation, or maintenance of a portion of the City Street System within the corporate limits of the City. Provided, nothing herein shall require the City to reimburse the Department for damages arising out of bodily injury to persons or damage to property caused by or resulting from the sole negligence of the Department. When any alleged act, omission, negligence, or misconduct may be subject to the limitations, exemptions, or defenses which may be raised under the ***Oklahoma Governmental Tort Claims Act***, 51 O.S. § 151 et seq., all such limitations, exemptions, and defenses shall be available to and may be asserted by City. No liability shall attach to the Department except as expressly provided herein.

15. Based on an estimated total construction cost plus construction inspection cost of Three-Million-Seven-Hundred-Thirty-Thousand-Dollars (\$3,730,000.00), it is agreed the project referenced above will be financed as follows:
- Federal STP funds shall be used to finance 80% of the federally participating construction costs of Two-Million-Nine-Hundred-Eighty-Four-Thousand-Dollars (\$2,984,000.00).
 - City funds provided by the City shall be provided to finance the balance of the eligible participating project construction costs, 20%, estimated at Seven-Hundred-Forty-Six-Thousand-Dollars (\$746,000.00). The CITY shall also provide 100% of any federally non-participating costs, estimated at Zero-Dollars (\$0.00). Total City funds are currently estimated at Seven-Hundred-Forty-Six-Thousand-Dollars (\$746,000.00). The estimated City funds shall be placed on deposit with the DEPARTMENT upon execution of this agreement and receipt of the Department's invoice, prior to advertising the project for bid.
16. a) It is understood by the City and the Department that the funding participation stipulated herein may be altered due to bid prices, construction supervision costs and federally non-participating costs incurred during construction.
- b) The DEPARTMENT, using its own forces or the services of others, will supervise and inspect all work performed by the construction contractor and will provide such engineering, inspection and testing services as may be required to ensure that the construction of the project is accomplished in accordance with the approved PS&E. Actual supervision and inspection costs shall be charged to the project and financed as described in PARAGRAPH 15 of this agreement.
- c) The City will be responsible for payment of estimated local funding prior to advertising the project for bid. Upon final acceptance of this project, the amount of federal funds and the amount previously deposited by the City will be deducted from the total cost and a refund will be made by the Department to the City or additional funding will be requested from the City. The City agrees to make arrangements for payment of any Department invoice within 45 days of receipt.
17. It is understood by the City that only those DEPARTMENT administered funding sources specified in Paragraph 15 of this agreement shall be made available for the financing of this project. All other costs are the responsibility of the CITY. No STATE funds are allocated to this project.
18. Upon approval of this Agreement and the plans, specifications and estimates by the City, Department and the Federal Highway Administration, if applicable, the Department shall agree to advertise and let the contract for this project in the usual and customary legal manner. It is agreed that the project herein described is proposed to be financed as previously set forth, and that this Agreement, all plans, specifications, estimates of costs, acceptance of work, payments and procedures in general hereunder are subject in all things at all times to all federal laws, regulations, orders and approvals as may be applicable hereto.

19. The Department agrees to construct said project in strict accordance with the plans furnished and approved by the City, provided that upon consultation with and agreement by the City, the Department shall have the right to make such changes in the plans and specifications as are necessary for the proper construction of the project. The Department shall provide competent supervision at all times that the work is in progress. The City shall have inspectors on the project site as the City determines necessary to ensure construction of the project to the satisfaction of the City and shall have representatives available for consultation with the Department representatives to cooperate fully to the end of obtaining work strictly in accordance with the City's approved plans and specifications.
20. The City agrees that it will intervene as a party defendant in all actions where a contractor may allege delay due to failure of the City to accomplish timely utility relocations, site conditions which are not represented on the plans or plan errors which impact on project constructability, whether in the District Court or in an alternative dispute resolution forum, will defend all such actions and will pay all damages relating to delay as may be assessed by such court or alternative dispute resolution forum against the City for its adjudged failure.
21. Failure by the City to fulfill its responsibilities under this Agreement will disqualify the City from future participation in any Federal-aid project. Federal funds are to be withheld until such time as the deficiencies in regulations have been corrected or the improvements to be constructed under this Agreement are brought to a satisfactory condition of maintenance.
22. It is further specifically agreed between the City and the Department that the project will be built in accordance with the plans and specifications, and upon final acceptance by the City and the Department of this project, the City does hereby accept full, complete and total responsibility for maintenance of this project as provided in this Agreement. The City does not waive any rights against any contractor(s) with respects to defects, hidden or otherwise, in materials or workmanship. The City does not, pursuant to this provision or any other provision in this Agreement, waive its sovereign immunity or any exemption from, exception to or limitation of liability as provided in the Governmental Tort Claims Act.
23. The Secretary of the Department may terminate this Agreement in whole or, from time to time, in part whenever:
 - a. The requisite federal funding becomes unavailable through failure of appropriation or otherwise.
 - b. The contractor is prevented from proceeding with the work as a direct result of an Executive Order of the President with respect to the prosecution of war or in the interest of national defense or an Executive Order of the President or Governor of the State with respect to the preservation of energy resources.
 - c. The contractor is prevented from proceeding with the work by reason of a preliminary, special or permanent restraining order of a court of competent jurisdiction where the issuance of such order is primarily caused by the acts or omissions of persons or agencies other than the contractor.

- d. The Secretary determines that such termination is in the best interest of the State.

REMAINDER OF PAGE INTENTIONALLY BLANK

IN WITNESS WHEREOF, the Deputy Director of the Department of Transportation, pursuant to authority vested in him by the State Transportation Commission, has hereunto subscribed his name as Deputy Director of the Department of Transportation and the City has executed same pursuant to authority prescribed by law for the City.

The City, _____ on this ___ of _____, 2019, and the Department on the ___ day of _____, 2019.

The City of Midwest City,
an Oklahoma Municipal Corporation

Mayor

(SEAL)

ATTEST:

City Clerk

Approved as to Form and Legality:

City Attorney

STATE OF OKLAHOMA
DEPARTMENT OF TRANSPORTATION

Recommended for Approval

Local Government Division Manager

Director of Capital Programs

APPROVED AS TO FORM
AND LEGALITY

APPROVED

General Counsel

Deputy Director

OKLAHOMA DEPARTMENT OF TRANSPORTATION

INVOICE

Make check PAYABLE, and MAIL TO:

**Oklahoma Department of Transportation
 Comptroller Division
 200 N.E. 21st Street
 Oklahoma City, Oklahoma 73105-3204**

To: The City of Midwest City

Department Invoice No 31548 (04)
 January 23, 2019

Description - Explanation of Charge	Quantity	Price Each	Total
Due Date: <u>Upon Receipt</u>			
Project Number: STPG-255B(461)AG Job Number: 31548(04)			
Total Estimated Cost including Inspection Cost:			\$3,730,000.00
Less Federal Share			(\$2,984,000.00)
Less Sponsor Initial Deposit			(\$ 0.00)
Local Share Due			<hr/> \$ 746,000.00
Accounting Use Only		Invoice Total	\$ 746,000.00

Distribution:

City
 Remit with Payment
 Division Project File
 Comptroller Division



The City of
MIDWEST CITY
COMMUNITY DEVELOPMENT DEPARTMENT -
ENGINEERING DIVISION

Billy Harless, Community Development Director
Patrick Menefee, P.E., City Engineer

ENGINEERING DIVISION
Patrick Menefee, City Engineer
CURRENT PLANNING DIVISION
Kellie Gilles, Manager
COMPREHENSIVE PLANNING
, Comprehensive Planner
BUILDING INSPECTION DIVISION
Christine Brakefield, Building Official
GIS DIVISION
Greg Hakinan, GIS Coordinator

TO: Honorable Mayor and Council

FROM: Patrick Menefee, P.E., City Engineer

DATE: February 12th, 2019

SUBJECT : Discussion and consideration of entering into a project agreement for Federal-aid Project Number NHPP-255N(496)AG, State Job Number 31546(04), with the Oklahoma Department of Transportation to receive federal funds in the amount of \$1,760,000.00 to mill, resurface, and reconstruct sidewalk on Douglas Boulevard from S.E. 4th Street to N.E. 10th Street.

The federal funds are needed in connection with the proposed construction of Douglas Boulevard from S.E. 4th Street to N.E. 10th Street. This includes expansion of the sidewalk network and the resurfacing of the roadway. The preliminary estimate for the total project cost is \$2,200,000. This project will be funded by 80% federal funds, 20% local match. The city will be required to contribute \$440,000 to ODOT to cover construction costs as required with the 20% local match provision.

Staff recommends approval.

p
City Engineer

Attachment

**PROJECT AGREEMENT
BETWEEN
THE OKLAHOMA DEPARTMENT OF TRANSPORTATION
AND
THE CITY OF MIDWEST CITY**

This Project Agreement ("Agreement") is made by and between the Oklahoma Department of Transportation, hereinafter referred to as the "Department," and the City of MIDWEST CITY, hereinafter referred to as the "City," which may be referred to collectively as the "Parties," for the following intents and purposes and subject to the following terms and conditions, to wit:

Project Type	DIV	County	JP No	Project No.	Work Type	Description
CITY STREET	04	OKLAHOMA	31546(04)	NHPP-255N (496) AG	RESURFACE	MILL RESURFACE AND RECONSTRUCT SIDEWALK: DOUGLAS BLVD FROM SE 4TH TO NE IORESURFACE AND SIDEWALK

WITNESSETH

WHEREAS, the Department is charged under the laws of the State of Oklahoma with construction and maintenance of State Highways; and,

WHEREAS, the Department is, by terms of agreements with the Federal Highway Administration, responsible for the management and construction of certain federally funded projects within the corporate limits of cities within the State of Oklahoma; and,

WHEREAS, the City has been identified as the beneficiary and sub-recipient of such federally funded project; and,

WHEREAS, receipt of the benefits of this project will require that the City assume certain financial responsibilities; and,

WHEREAS, the City is a municipal corporation created and existing under the constitution and laws of the State of Oklahoma; and,

WHEREAS, the laws and constitution of the State of Oklahoma impose financial restrictions on the City and its ability to ensure financial obligations; and,

WHEREAS, the Parties hereto recognize those financial limitations and agree that the financial obligations assumed by the City, by the terms of this Agreement, are enforceable only to the extent as may be allowed by law or as may be determined by a court of competent jurisdiction; and,

WHEREAS, it is understood that, by virtue of the Article 10, Section 26 of the Oklahoma Constitution, the payment of City funds in the future will be limited to appropriations and available funds in the then current City fiscal year.

NOW THEREFORE, subject to the limitations hereinbefore described, the Department and the City do agree as follows:

1. The City requested that certain street improvements be approved by the Oklahoma Transportation Commission, as were previously programmed by the City and **described as follows:**

Project Type	DIV	County	JPNO	Project No.	Work Type	Description
CITY STREET	04	OKLAHOMA	31546(04)	NHPP -255N (496) AG	RESURFACE	MILL RESURFACE AND RECONSTRUCT SIDEWALK: DOUGLAS BLVD FROM SE 4TH TO NE IORESURFACE AND SIDEWALK

2. The City shall prepare, or cause to be prepared, plans for construction of this federal-aid project and agrees that all construction shall be in conformance with the furnished plans, which are incorporated with and made part of this Agreement.
3. The City agrees that the furnished plans at the time of bidding, are at a minimum, in compliance with the current Oklahoma Department of Transportation Standard Specifications for Highway Construction.
4.
 - A. The City shall be responsible for furnishing all right-of-way for this federal-aid project in compliance with all applicable laws, federal regulations, and guidelines established by the USDOT's FHWA's Office of Real Estate Services, including 42 USC, Chapter 6l (The Uniform Act) and 49 CFR Part 24, (Uniform Relocation Assistance and Real Property Acquisition For Federal and Federally Assisted Programs), as well as applicable State Statutes, Oklahoma Administrative Codes, and Department Policy; free and clear of all obstructions and encroachments; and that the City shall, at its sole expense, maintain the project after construction.
 - B. The City shall keep all permanent right-of-way shown on said plans free from any encroachment and take timely action to effect the removal of any encroachments upon notification by the Department, including all necessary legal action when required.
 - C. The City shall acquire all right-of-way, if any, be responsible for the total costs for removing and relocating outdoor advertising signs and for the relocation assistance payments to persons displaced by reason of the acquisition of right-of-way and be responsible for the removal or relocation of all utility lines on public or private rights-of-way to accommodate the construction of this project, and comply with these additional requirements:
 1. Transmit copies of the instruments, including all deeds and easements, to the Department prior to the advertisement of bids for construction.
 2. Comply with the provisions of 42 U.S.C.A. § 4601-4655 and 23 U.S.C.A. § 323 (as amended) and, further comply with 49 C.F.R. Part 24 in the acquisition of all necessary right-of-way and relocation of all displacees.

3. Convey title to the State of Oklahoma on all tracts of land acquired in the name of the City if the project is located on the State Highway System.

D. If the acquisition of right-of-way for this project causes the displacement of any person, business or non-profit organization, the City will provide and be responsible for the Relocation Assistance Program and for all cost associated with the relocation assistance payments. The Department will supply a list of approved service providers qualified to administer the Relocation Assistance Program. The City agrees to employ a service provider from the approved list and comply with all applicable rules, regulations, statutes, policies and procedures of both the United States and the State of Oklahoma. Before any relocation assistance payments are made, (if applicable), all files with parcels requiring relocation shall be audited by the Department. The Department shall be notified in writing within seven (7) days of the date of the offer to the property owner on any parcel which will require relocation assistance. Written notifications of offers to acquire shall be addressed to Project Manager, Right-of-Way Division, Oklahoma Department of Transportation, 200 N. E. 21st Street, Oklahoma City, Oklahoma 73105.

5. The City agrees to the location of the subject project and agrees to adopt the final plans for said project as the official plans of the City for the streets, boulevards, arterial highways and/or other improvements contained therein; and further, the City affirmatively states that it has or shall fully and completely examine the plans and shall hereby warrant to the Department, the City's complete satisfaction with these plans and the fitness of the plans to construct aforesaid project.
6. A. The City certifies that the project design plans shall comply, and the project when completed will comply, with the requirements of the Americans with Disabilities Act (ADA) of 1990 (42 U.S.C. §§ 12101 - 12213), 49 CFR Parts 27, 37 and 38 and 28 CFR parts 35 and 36. The City shall be exclusively responsible for integrated ADA compliance planning for all City streets, sidewalks and other facilities provided for public administration, use and accommodation, which is required of recipients and sub-recipients by 49 CFR § 27.11. State highways continued through corporate limits of the City shall be included in the City's comprehensive compliance plans.

B The CITY agrees to comply with the **The Americans with Disabilities Act Non-Discrimination Clause** which is incorporated into this agreement as the attached ADA Exhibit.

7. The Parties hereto agree to comply with all applicable laws and regulations meeting Environmental Protection Agency (EPA) requirements for pollution prevention, including discharges from storm water runoff on this project. The Department shall require the contractor who may be awarded the project to meet all Oklahoma Department of Environmental Quality (ODEQ) requirements for storm water runoff on this project. It is agreed that the project plans and specifications, required schedules for accomplishing the temporary and permanent erosion control work, the Storm Water Management Plan (SWMP) sheet and appropriate U.S. Geological Survey (USGS) topographic map contained in the plans constitute the SWMP for the project described previously in this document. Further, if required, the Department shall require the contractor to file a Notice of Intent (NOI) for storm

water discharges associated with construction activity under the Oklahoma Pollutant Discharges Elimination System (OPDES) General Permit with ODEQ, which authorizes the storm water discharges associated with construction activity from the construction site, and to develop, if required, a Storm Water Pollution Prevention Plan (SWPPP).

- 8 The City agrees that prior to the Department's advertising of the project for bids (as to that part of the project lying within the present corporate limits) it will:
- (a) Grant to the Department and its contractors, the right-of-entry to all existing streets, alleys, and City owned property when required, and other rights-of-way shown on said plans.
 - (b) Remove at its own expense, or cause the removal of, all encroachments on existing streets as shown on said plans, including all signs, buildings, porches, awnings, porticos, fences, gasoline pumps and islands, and any other such private installations.
 - (c) To prohibit parking on that portion of the project within the corporate limits of the City, except as may be indicated in the plans or hereafter approved by agreement with the Department. The City further agrees not to install, or permit to be installed, any signs, signals or markings not in conformance with the standards approved by the Federal Highway Administration and Manual on Uniform Traffic Control Devices (MUTCD).
 - (d) Comply with the Department's standards for construction of driveway entrances from private property to the highway, in accordance with the Department's manual entitled "Policy on Driveway Regulation for Oklahoma Highways", Rev. 5/96, 69 O.S. (2001) § 1210.
 - (e) Maintain all right of way acquired for the construction of this project, as shown on said plans, in a manner consistent with applicable statutes, codes, ordinances and regulations of the Department and the State of Oklahoma.
 - (f) The City shall have the authority pursuant to 69 O.S. 2001 § 1001 and 69 O.S. 2001 § 1004 to sell any lands, or interest therein, which were acquired for highway purposes as long as such sale is conducted in accordance with the above cited statutes. Prior written approval by the Chief, Right-of-Way Division for the Department shall be required before any sale is made.
9. The City further agrees and warrants to the Department that, subsequent to the construction of said project, the City will:
- a Erect, maintain and operate traffic control devices, including signals, signs and pavement markings only in accordance with 47 O.S. 2011 §§ 15-104- 15-106, and subject to agreement of the Department:
 - l) In the event that any traffic signal installed hereunder is no longer needed for the purposes designated herein, then the traffic signal installed hereunder shall not be removed by the City to any other point other than that which is approved by the Department prior to such removal.

- 2) In the event there is no mutually agreed location for the reinstallation, the City will assume complete ownership of the equipment following removal if the installation is ten (10) years old or older. If the installation is less than ten (10) years old and:
 - a) In the event City desires total ownership of the equipment, the City shall reimburse the Department the original federal funding percentage share for the original equipment cost only, amortized for a ten (10) year service life, interest ignored, and assuming straight line depreciation.
 - b) In the event the City does not desire total ownership of the equipment, the City shall sell the equipment at public auction to the highest bidder. The City shall reimburse the Department the original federal funding percentage share of the proceeds of such sale.
- b) Subject to agreement with the Department, regulate and control traffic on said project, including but not limited to, the speed of vehicles, parking, stopping and turns only in accordance with 47 O.S. 2011 §§ 15-104- 15-106, and to make no changes in the provisions thereof without the approval of the Department. It shall be the responsibility of the City to notify the Department of any changes necessary to ensure safety to the traveling public.
- c) Maintain all drainage systems and facilities constructed, installed, modified or repaired in conjunction with this project or as may be otherwise necessary to ensure proper drainage for road surfaces constructed under the terms of this Agreement.
- d) Maintain all curbs and driveways abutting road surfaces constructed under the terms of this Agreement and all sidewalks adjacent thereto.
- e) Maintain all right-of-way areas adjacent to road surfaces, including erosion control and period mowing of vegetation, in a manner consistent with applicable codes, ordinances and regulations.
- f) Make ample provision annually for proper maintenance of items heretofore delineated as the responsibility of the City, including the provision of competent personnel and adequate equipment, and specifically, to provide all required special maintenance of the project during the critical period immediately following constructions.
- g) Keep all permanent right-of-way shown on said plans free from any encroachment and take immediate action to effect the removal of any encroachments upon notification by the Department.
- h) For any portion of the project encompassed under this agreement that is part of the State Highway System, the City shall maintain all that part of said project within the corporate limits of the City between the gutter lines and the right-of-way lines, and if no gutter exists, between the shoulder lines and the right-of-way lines, including storm

sewers, all underground facilities, curbs and mowing, all in accordance with 69 O.S. Supp. 1994 §901 and all other applicable law.

- i On limited access highways where county roads or city streets extend over or under the highway or public roads are constructed on state rights-of-way but there is no immediate ingress and egress from the highway, responsibility shall be as follows:

- (1) The public roads as defined in OAC 730:35-1-2 shall be maintained by the city or county and shall be included in their roadway mileage inventory.

- (2) Where county roads or city streets extend over the highway, the roadway, approaches and bridge surfaces, including the deck, shall be maintained by the city or county. The approach guardrail, bridge structure, and highest clearance posting on the structure shall be maintained by the Department.

- (3) Where county roads or city streets extend under the highway, the roadway approaches and advance signing shall be maintained by the city or county. The Department shall maintain the approach guardrail, bridge structure and surface, and the height clearance posting on the structure.

- 10. The City further agrees and warrants to the Department concerning any sign and highway facility lighting included as part of this project:

- a. The City will, upon notice from the Department Engineer, provide at its own expense all required electrical energy necessary for all preliminary and operational tests of the highway lighting facilities.
- b. Upon completion of the construction of said project, the City will be responsible for the maintenance and cost of operation of these highway lighting facilities, including all appurtenances thereto and including the sign lighting facilities.
- c. It is specifically understood and agreed that the highway lighting and sign lighting facilities specified hereunder shall be continuously operated during the hours of darkness, between sunset and sunrise, and shall not be altered, removed or be allowed to cease operation without the mutual written consent of the Department and the City.
- d. The City agrees to provide, on a periodic schedule, an inspection, cleaning and re-lamping maintenance program to assure the maximum efficiency of the highway lighting facilities.
- e. In the event that the highway lighting facilities installed hereunder are no longer needed for the purposes designated herein, then the highway lighting facilities installed hereunder shall not be removed by the City to any point other than which is approved by the Department prior to such removal.

- f. In the event there is no mutually agreed location for reinstallation, the City will assume complete ownership of the equipment following removal if the installation is twenty (20) years old or older. If the installation is less than twenty years old and:
- 1) In the event the City desires total ownership of the equipment, the City shall reimburse the Department the original federal funding percentage share of the original equipment costs only, amortized for a twenty (20) year service life, interest ignored, and assuming straight line depreciation.
 - 2) In the event the City does not desire total ownership of the equipment, the City shall sell the equipment at public auction to the highest bidder. The City shall reimburse the Department the original federal funding percentage share of the proceeds of such sale.
11. The City agrees, affirms and warrants to the Department that the City will be responsible, during the period of construction, for any repairs or maintenance to the approved detour route or any other street which may be required as a result of additional traffic.
12. The City agrees to comply with Title VI of the Civil Rights Act of 1964, 78 O.S. § 252.42, 42 U.S.C. § 200d et seq., and all requirements imposed by or pursuant to 49 CFR, Part 21, "Nondiscrimination in Federally Assisted Programs of the Department of Transportation - Effectuation of Title VI of the Civil Rights Act of 1964."
13. The City agrees that it will, by resolution, duly authorize the execution of this Agreement by the proper officials and attach copies of such resolution to this Agreement.
14. To the extent permitted by the *Oklahoma Governmental Tort Claims Act*, Title 51 Oklahoma Statutes, Sections 151 et seq. and by Oklahoma Constitution Article 10, section 26 and as otherwise permitted by law, the City shall indemnify and save harmless the Department, its officers and employees, and shall process and defend at its own expense all claims, demands, or suits whether in law or equity brought against the City or the Department arising from the City's execution, performance, or failure to perform, and provisions of this agreement or alleged negligence in the location, design, construction, operation, or maintenance of a portion of the City Street System within the corporate limits of the City. Provided, nothing herein shall require the City to reimburse the Department for damages arising out of bodily injury to persons or damage to property caused by or resulting from the sole negligence of the Department. When any alleged act, omission, negligence, or misconduct may be subject to the limitations, exemptions, or defenses which may be raised under the *Oklahoma Governmental Tort Claims Act*, 51 O.S. § 151 et seq., all such limitations, exemptions, and defenses shall be available to and may be asserted by City. No liability shall attach to the Department except as expressly provided herein.

15. Based on an estimated total construction cost plus construction inspection cost of Two-Million-Two-Hundred-Thousand-Dollars (\$2,200,000.00), it is agreed the project referenced above will be financed as follows:
- Federal STP funds shall be used to finance 80% of the federally participating construction costs of One-Million-Seven-Hundred-Sixty-Thousand-Dollars (\$1,760,000.00).
 - City funds provided by the City shall be provided to finance the balance of the eligible participating project construction costs, 20%, estimated at Four-Hundred-Forty-Thousand-Dollars (\$440,000.00). The CITY shall also provide 100% of any federally non-participating costs, estimated at Zero-Dollars (\$0.00). Total City funds are currently estimated at Four-Hundred-Forty-Thousand-Dollars (\$440,000.00). The estimated City funds shall be placed on deposit with the DEPARTMENT upon execution of this agreement and receipt of the Department's invoice, prior to advertising the project for bid.
16. a) It is understood by the City and the Department that the funding participation stipulated herein may be altered due to bid prices, construction supervision costs and federally non- participating costs incurred during construction.
- b) The DEPARTMENT, using its own forces or the services of others, will supervise and inspect all work performed by the construction contractor and will provide such engineering, inspection and testing services as may be required to ensure that the construction of the project is accomplished in accordance with the approved PS&E. Actual supervision and inspection costs shall be charged to the project and financed as described in PARAGRAPH 15 of this agreement.
- c) The City will be responsible for payment of estimated local funding prior to advertising the project for bid. Upon final acceptance of this project, the amount of federal funds and the amount previously deposited by the City will be deducted from the total cost and a refund will be made by the Department to the City or additional funding will be requested from the City. The City agrees to make arrangements for payment of any Department invoice within 45 days of receipt.
17. It is understood by the City that only those DEPARTMENT administered funding sources specified in Paragraph 15 of this agreement shall be made available for the financing of this project. All other costs are the responsibility of the CITY. No STATE funds are allocated to this project.
18. Upon approval of this Agreement and the plans, specifications and estimates by the City, Department and the Federal Highway Administration, if applicable, the Department shall agree to advertise and let the contract for this project in the usual and customary legal manner. It is agreed that the project herein described is proposed to be financed as previously set forth, and that this Agreement, all plans, specifications, estimates of costs, acceptance of work, payments and procedures in general hereunder are subject in all things at all times to all federal laws, regulations, orders and approvals as may be applicable hereto.

19. The Department agrees to construct said project in strict accordance with the plans furnished and approved by the City, provided that upon consultation with and agreement by the City, the Department shall have the right to make such changes in the plans and specifications as are necessary for the proper construction of the project. The Department shall provide competent supervision at all times that the work is in progress. The City shall have inspectors on the project site as the City determines necessary to ensure construction of the project to the satisfaction of the City and shall have representatives available for consultation with the Department representatives to cooperate fully to the end of obtaining work strictly in accordance with the City's approved plans and specifications.
20. The City agrees that it will intervene as a party defendant in all actions where a contractor may allege delay due to failure of the City to accomplish timely utility relocations, site conditions which are not represented on the plans or plan errors which impact on project constructability, whether in the District Court or in an alternative dispute resolution forum, will defend all such actions and will pay all damages relating to delay as may be assessed by such court or alternative dispute resolution forum against the City for its adjudged failure.
21. Failure by the City to fulfill its responsibilities under this Agreement will disqualify the City from future participation in any Federal-aid project. Federal funds are to be withheld until such time as the deficiencies in regulations have been corrected or the improvements to be constructed under this Agreement are brought to a satisfactory condition of maintenance.
22. It is further specifically agreed between the City and the Department that the project will be built in accordance with the plans and specifications, and upon final acceptance by the City and the Department of this project, the City does hereby accept full, complete and total responsibility for maintenance of this project as provided in this Agreement. The City does not waive any rights against any contractor(s) with respects to defects, hidden or otherwise, in materials or workmanship. The City does not, pursuant to this provision or any other provision in this Agreement, waive its sovereign immunity or any exemption from, exception to or limitation of liability as provided in the Governmental Tort Claims Act.
23. The Secretary of the Department may terminate this Agreement in whole or, from time to time, in part whenever:
 - a. The requisite federal funding becomes unavailable through failure of appropriation or otherwise.
 - b. The contractor is prevented from proceeding with the work as a direct result of an Executive Order of the President with respect to the prosecution of war or in the interest of national defense or an Executive Order of the President or Governor of the State with respect to the preservation of energy resources.
 - c. The contractor is prevented from proceeding with the work by reason of a preliminary, special or permanent restraining order of a court of competent jurisdiction where the issuance of such order is primarily caused by the acts or omissions of persons or agencies other than the contractor.

- d. The Secretary determines that such termination is in the best interest of the State.

REMAINDER OF PAGE INTENTIONALLY BLANK

IN WITNESS WHEREOF, the Deputy Director of the Department of Transportation, pursuant to authority vested in him by the State Transportation Commission, has hereunto subscribed his name as Deputy Director of the Department of Transportation and the City has executed same pursuant to authority prescribed by law for the City.

The City, _____ on this __ of _____, 2019, and the Department on the
__ day of _____, 2019.

The City of Midwest City,
an Oklahoma Municipal Corporation

Mayor

(SEAL)

ATTEST:

City Clerk

Approved as to Form and Legality:

City Attorney

STATE OF OKLAHOMA
DEPARTMENT OF TRANSPORTATION

Recommended for Approval

Local Government Division Manager

Director of Capital Programs

APPROVED AS TO FORM
AND LEGALITY

APPROVED

General Counsel

Deputy Director

OKLAHOMA DEPARTMENT OF TRANSPORTATION

INVOICE

Make check PAYABLE, and MAIL TO:

**Oklahoma Department of Transportation
 Comptroller Division
 200 N.E. 21st Street
 Oklahoma City, Oklahoma 73105-3204**

To: The City of Midwest City

Department Invoice No 31546(04)
 January 23, 2019

Description - Explanation of Charge	Quantity	Price Each	Total
Due Date: <u> Upon Receipt </u>			
Project Number: NHPP-255N(496)AG Job Number: 31546(04)			
Total Estimated Cost including Inspection Cost:			\$2,200,000.00
Less Federal Share			(\$1,760,000.00)
Less Sponsor Initial Deposit			(\$ 0,00.00)
Local Share Due			<u>\$440,000.00</u>
Accounting Use Only		Invoice Total	\$440,000.00

Distribution:

City
 Remit with Payment
 Division Project File
 Comptroller Division



The City of
MIDWEST CITY
COMMUNITY DEVELOPMENT DEPARTMENT -
ENGINEERING DIVISION

Billy Harless, Community Development Director
Patrick Menefee, P.E., City Engineer

ENGINEERING DIVISION
Patrick Menefee, City Engineer
CURRENT PLANNING DIVISION
Kellie Gilles, Manager
COMPREHENSIVE PLANNING
, Comprehensive Planner
BUILDING INSPECTION DIVISION
Christine Brakeliled, Building Official
GJS DIVISION
Greg Halanan, GIS Coordinator

TO: Honorable Mayor and Council

FROM: Patrick Menefee, P.E., City Engineer

DATE: February 12th, 2019

SUBJECT : Discussion and consideration of entering into a project agreement for Federal-aid Project Number STPG-255F(482)AG, State Job Number 33739(04), with the Oklahoma Department of Transportation to receive federal funds in the amount of \$466,000.00 to construct the Midwest City Signals to be installed at following two intersections: Douglas Boulevard and Orchard Boulevard and Air Depot at the Rail with Trail crossing.

The federal funds are needed in connection with the proposed construction of the signals at Douglas Boulevard and Orchard Boulevard and Air Depot at the Rail with Trail crossing. The preliminary estimate for the total project cost is \$466,000. Being part of ODOT's safety project program, the project will be funded by 100% federal funds.

Staff recommends approval.

—
p
City Engineer

Attachment

**PROJECT AGREEMENT
BETWEEN
THE OKLAHOMA DEPARTMENT OF TRANSPORTATION
AND
THE CITY OF MIDWEST CITY**

This Project Agreement ("Agreement") is made by and between the Oklahoma Department of Transportation, hereinafter referred to as the "Department," and the City of MIDWEST CITY, hereinafter referred to as the "City," which may be referred to collectively as the "Parties," for the following intents and purposes and subject to the following terms and conditions, to wit:

Project Type	DIV	County	JP No	Project No.	Work Type	Description
CITY STREET	04	OKIAHOMA	33739(041	STPG-255F (482)AG	SAFETY IMPROVEMENT	MIDWEST CITY: SIGNALS TO BE INSTALLED AT THE FOLLOWING LOCATIONS; DOUGIAS BLVD AND ORCHARD ST, AIR DEPOT AND RAIL WITH TRAIL LOCATION

WITNESSETH

WHEREAS, the Department is charged under the laws of the State of Oklahoma with construction and maintenance of State Highways; and,

WHEREAS, the Department is, by terms of agreements with the Federal Highway Administration, responsible for the management and construction of certain federally funded projects within the corporate limits of cities within the State of Oklahoma; and,

WHEREAS, the City has been identified as the beneficiary and sub-recipient of such federally funded project; and,

WHEREAS, receipt of the benefits of this project will require that the City assume certain financial responsibilities; and,

WHEREAS, the City is a municipal corporation created and existing under the constitution and laws of the State of Oklahoma; and,

WHEREAS, the laws and constitution of the State of Oklahoma impose financial restrictions on the City and its ability to ensure financial obligations; and,

WHEREAS, the Parties hereto recognize those financial limitations and agree that the financial obligations assumed by the City, by the terms of this Agreement, are enforceable only to the extent as may be allowed by law or as may be determined by a court of competent jurisdiction; and,

WHEREAS, it is understood that, by virtue of the Article 10, Section 26 of the Oklahoma Constitution, the payment of City funds in the future will be limited to appropriations and available funds in the then current City fiscal year.

NOW THEREFORE, subject to the limitations hereinbefore described, the Department and the City do agree as follows:

1. The City requested that certain street improvements be approved by the Oklahoma Transportation Commission, as were previously programmed by the City and **described as follows**:

Project Type	DIV	County	JP No	Project No.	Work Type	Description
CITY STREET	04	OKLAHOMA	33739(041	STPG-255F (482)AG	SAFETY IMPROVEMENT	MIDWEST CITY: SIGNALS TO BE INSTALLED AT THE FOLLOWING LOCATIONS; DOUGLAS BLVD AND ORCHARD ST, AIR DEPOT AND RAIL WITH TRAIL LOCATION

2. The City shall prepare, or cause to be prepared, plans for construction of this federal-aid project and agrees that all construction shall be in conformance with the furnished plans, which are incorporated with and made part of this Agreement.
3. The City agrees that the furnished plans at the time of bidding, are at a minimum, in compliance with the current Oklahoma Department of Transportation Standard Specifications for Highway Construction.
4.
 - A. The City shall be responsible for furnishing all right-of-way for this federal-aid project in compliance with all applicable laws, federal regulations, and guidelines established by the USDOT's FHWA's Office of Real Estate Services, including 42 USC, Chapter 6l (The Uniform Act) and 49 CFR Part 24, (Uniform Relocation Assistance and Real Property Acquisition For Federal and Federally Assisted Programs), as well as applicable State Statutes, Oklahoma Administrative Codes, and Department Policy; free and clear of all obstructions and encroachments; and that the City shall, at its sole expense, maintain the project after construction.
 - B. The City shall keep all permanent right-of-way shown on said plans free from any encroachment and take timely action to effect the removal of any encroachments upon notification by the Department, including all necessary legal action when required.
 - C. The City shall acquire all right-of-way, if any, be responsible for the total costs for removing and relocating outdoor advertising signs and for the relocation assistance payments to persons displaced by reason of the acquisition of right-of-way and be responsible for the removal or relocation of all utility lines on public or private rights-of-way to accommodate the construction of this project, and comply with these additional requirements:
 1. Transmit copies of the instruments, including all deeds and easements, to the Department prior to the advertisement of bids for construction.
 2. Comply with the provisions of 42 U.S.C.A. § 4601-4655 and 23 U.S.C.A. § 323 (as amended) and, further comply with 49 C.F.R. Part 24 in the acquisition of all necessary right-of-way and relocation of all displacees.

3. Convey title to the State of Oklahoma on all tracts of land acquired in the name of the City if the project is located on the State Highway System.

D. If the acquisition of right-of-way for this project causes the displacement of any person, business or non-profit organization, the City will provide and be responsible for the Relocation Assistance Program and for all cost associated with the relocation assistance payments. The Department will supply a list of approved service providers qualified to administer the Relocation Assistance Program. The City agrees to employ a service provider from the approved list and comply with all applicable rules, regulations, statutes, policies and procedures of both the United States and the State of Oklahoma. Before any relocation assistance payments are made, (if applicable), all files with parcels requiring relocation shall be audited by the Department. The Department shall be notified in writing within seven (7) days of the date of the offer to the property owner on any parcel which will require relocation assistance. Written notifications of offers to acquire shall be addressed to Project Manager, Right-of-Way Division, Oklahoma Department of Transportation, 200 N. E. 21st Street, Oklahoma City, Oklahoma 73105.

5. The City agrees to the location of the subject project and agrees to adopt the final plans for said project as the official plans of the City for the streets, boulevards, arterial highways and/or other improvements contained therein; and further, the City affirmatively states that it has or shall fully and completely examine the plans and shall hereby warrant to the Department, the City's complete satisfaction with these plans and the fitness of the plans to construct aforesaid project.
6. A. The City certifies that the project design plans shall comply, and the project when completed will comply, with the requirements of the Americans with Disabilities Act (ADA) of 1990 (42 U.S.C. §§ 12101 - 12213), 49 CFR Parts 27, 37 and 38 and 28 CFR parts 35 and 36. The City shall be exclusively responsible for integrated ADA compliance planning for all City streets, sidewalks and other facilities provided for public administration, use and accommodation, which is required of recipients and sub-recipients by 49 CFR § 27.11. State highways continued through corporate limits of the City shall be included in the City's comprehensive compliance plans.

R The CITY agrees to comply with the **The Americans with Disabilities Act Non-Discrimination Clause** which is incorporated into this agreement as the attached ADA Exhibit.

7. The Parties hereto agree to comply with all applicable laws and regulations meeting Environmental Protection Agency (EPA) requirements for pollution prevention, including discharges from storm water runoff on this project. The Department shall require the contractor who may be awarded the project to meet all Oklahoma Department of Environmental Quality (ODEQ) requirements for storm water runoff on this project. It is agreed that the project plans and specifications, required schedules for accomplishing the temporary and permanent erosion control work, the Storm Water Management Plan (SWMP) sheet and appropriate U.S. Geological Survey (USGS) topographic map contained in the plans constitute the SWMP for the project described previously in this document. Further, if required, the Department shall require the contractor to file a Notice of Intent (NOi) for storm

water discharges associated with construction activity under the Oklahoma Pollutant Discharges Elimination System (OPDES) General Permit with ODEQ, which authorizes the storm water discharges associated with construction activity from the construction site, and to develop, if required, a Storm Water Pollution Prevention Plan (SWPPP).

8. The City agrees that prior to the Department's advertising of the project for bids (as to that part of the project lying within the present corporate limits) it will:
- (a) Grant to the Department and its contractors, the right-of-entry to all existing streets, alleys, and City owned property when required, and other rights-of-way shown on said plans.
 - (b) Remove at its own expense, or cause the removal of, all encroachments on existing streets as shown on said plans, including all signs, buildings, porches, awnings, porticos, fences, gasoline pumps and islands, and any other such private installations.
 - (c) To prohibit parking on that portion of the project within the corporate limits of the City, except as may be indicated in the plans or hereafter approved by agreement with the Department. The City further agrees not to install, or permit to be installed, any signs, signals or markings not in conformance with the standards approved by the Federal Highway Administration and Manual on Uniform Traffic Control Devices (MUTCD).
 - (d) Comply with the Department's standards for construction of driveway entrances from private property to the highway, in accordance with the Department's manual entitled "Policy on Driveway Regulation for Oklahoma Highways", Rev. 5/96, 69 O.S. (2001) § 1210.
 - (e) Maintain all right of way acquired for the construction of this project, as shown on said plans, in a manner consistent with applicable statutes, codes, ordinances and regulations of the Department and the State of Oklahoma.
 - (f) The City shall have the authority pursuant to 69 O.S. 2001 § 1001 and 69 O.S. 2001 § 1004 to sell any lands, or interest therein, which were acquired for highway purposes as long as such sale is conducted in accordance with the above cited statutes. Prior written approval by the Chief, Right-of-Way Division for the Department shall be required before any sale is made.
9. The City further agrees and warrants to the Department that, subsequent to the construction of said project, the City will:
- a. Erect, maintain and operate traffic control devices, including signals, signs and pavement markings only in accordance with 47 O.S. 2011 §§ 15-104- 15-106, and subject to agreement of the Department:
 - 1) In the event that any traffic signal installed hereunder is no longer needed for the purposes designated herein, then the traffic signal installed hereunder shall not be removed by the City to any other point other than that which is approved by the Department prior to such removal.

- 2) In the event there is no mutually agreed location for the reinstallation, the City will assume complete ownership of the equipment following removal if the installation is ten (10) years old or older. If the installation is less than ten (10) years old and:
 - a) In the event City desires total ownership of the equipment, the City shall reimburse the Department the original federal funding percentage share for the original equipment cost only, amortized for a ten (10) year service life, interest ignored, and assuming straight line depreciation.
 - b) In the event the City does not desire total ownership of the equipment, the City shall sell the equipment at public auction to the highest bidder. The City shall reimburse the Department the original federal funding percentage share of the proceeds of such sale.
- b) Subject to agreement with the Department, regulate and control traffic on said project, including but not limited to, the speed of vehicles, parking, stopping and turns only in accordance with 47 O.S. 2011 §§ 15-104- 15-106, and to make no changes in the provisions thereof without the approval of the Department. It shall be the responsibility of the City to notify the Department of any changes necessary to ensure safety to the traveling public.
- c) Maintain all drainage systems and facilities constructed, installed, modified or repaired in conjunction with this project or as may be otherwise necessary to ensure proper drainage for road surfaces constructed under the terms of this Agreement.
- d) Maintain all curbs and driveways abutting road surfaces constructed under the terms of this Agreement and all sidewalks adjacent thereto.
- e) Maintain all right-of-way areas adjacent to road surfaces, including erosion control and period mowing of vegetation, in a manner consistent with applicable codes, ordinances and regulations.
- f) Make ample provision annually for proper maintenance of items heretofore delineated as the responsibility of the City, including the provision of competent personnel and adequate equipment, and specifically, to provide all required special maintenance of the project during the critical period immediately following constructions.
- g) Keep all permanent right-of-way shown on said plans free from any encroachment and take immediate action to effect the removal of any encroachments upon notification by the Department.
- h) For any portion of the project encompassed under this agreement that is part of the State Highway System, the City shall maintain all that part of said project within the corporate limits of the City between the gutter lines and the right-of-way lines, and if no gutter exists, between the shoulder lines and the right-of-way lines, including storm

sewers, all underground facilities, curbs and mowing, all in accordance with 69 O.S. Supp. 1994 §901 and all other applicable law.

- i. On limited access highways where county roads or city streets extend over or under the highway or public roads are constructed on state rights-of-way but there is no immediate ingress and egress from the highway, responsibility shall be as follows:
 - (1) The public roads as defined in OAC 730:35-1-2 shall be maintained by the city or county and shall be included in their roadway mileage inventory.
 - (2) Where county roads or city streets extend over the highway, the roadway, approaches and bridge surfaces, including the deck, shall be maintained by the city or county. The approach guardrail, bridge structure, and highest clearance posting on the structure shall be maintained by the Department.
 - (3) Where county roads or city streets extend under the highway, the roadway approaches and advance signing shall be maintained by the city or county. The Department shall maintain the approach guardrail, bridge structure and surface, and the height clearance posting on the structure.
10. The City further agrees and warrants to the Department concerning any sign and highway facility lighting included as part of this project:
- a. The City will, upon notice from the Department Engineer, provide at its own expense all required electrical energy necessary for all preliminary and operational tests of the highway lighting facilities.
 - b. Upon completion of the construction of said project, the City will be responsible for the maintenance and cost of operation of these highway lighting facilities, including all appurtenances thereto and including the sign lighting facilities.
 - c. It is specifically understood and agreed that the highway lighting and sign lighting facilities specified hereunder shall be continuously operated during the hours of darkness, between sunset and sunrise, and shall not be altered, removed or be allowed to cease operation without the mutual written consent of the Department and the City.
 - d. The City agrees to provide, on a periodic schedule, an inspection, cleaning and re-lamping maintenance program to assure the maximum efficiency of the highway lighting facilities.
 - e. In the event that the highway lighting facilities installed hereunder are no longer needed for the purposes designated herein, then the highway lighting facilities installed hereunder shall not be removed by the City to any point other than which is approved by the Department prior to such removal.

- f In the event there is no mutually agreed location for reinstallation, the City will assume complete ownership of the equipment following removal if the installation is twenty (20) years old or older. If the installation is less than twenty years old and:
- 1) In the event the City desires total ownership of the equipment, the City shall reimburse the Department the original federal funding percentage share of the original equipment costs only, amortized for a twenty (20) year service life, interest ignored, and assuming straight line depreciation.
 - 2) In the event the City does not desire total ownership of the equipment, the City shall sell the equipment at public auction to the highest bidder. The City shall reimburse the Department the original federal funding percentage share of the proceeds of such sale.
11. The City agrees, affirms and warrants to the Department that the City will be responsible, during the period of construction, for any repairs or maintenance to the approved detour route or any other street which may be required as a result of additional traffic.
 12. The City agrees to comply with Title VI of the Civil Rights Act of 1964, 78 O.S. § 252.42, 42 U.S.C. §§ 200d et seq., and all requirements imposed by or pursuant to 49 CFR, Part 21, "Nondiscrimination in Federally Assisted Programs of the Department of Transportation - Effectuation of Title VI of the Civil Rights Act of 1964."
 13. The City agrees that it will, by resolution, duly authorize the execution of this Agreement by the proper officials and attach copies of such resolution to this Agreement.
 14. To the extent permitted by the ***Oklahoma Governmental Tort Claims Act***, Title 51 Oklahoma Statutes, Sections 151 *et seq.* and by Oklahoma Constitution Article 10, section 26 and as otherwise permitted by law, the City shall indemnify and save harmless the Department, its officers and employees, and shall process and defend at its own expense all claims, demands, or suits whether in law or equity brought against the City or the Department arising from the City's execution, performance, or failure to perform, and provisions of this agreement or alleged negligence in the location, design, construction, operation, or maintenance of a portion of the City Street System within the corporate limits of the City. Provided, nothing herein shall require the City to reimburse the Department for damages arising out of bodily injury to persons or damage to property caused by or resulting from the sole negligence of the Department. When any alleged act, omission, negligence, or misconduct may be subject to the limitations, exemptions, or defenses which may be raised under the ***Oklahoma Governmental Tort Claims Act***, 51 O.S. § 151 et seq., all such limitations, exemptions, and defenses shall be available to and may be asserted by City. No liability shall attach to the Department except as expressly provided herein.

15. Based on an estimated total construction cost plus construction inspection cost of Four-Hundred-Sixty-Six-Thousand-Dollars (\$466,000.00), it is agreed the project referenced above will be financed as follows:
- Federal STP funds shall be used to finance 100% of the federally participating construction costs of Four-Hundred-Sixty-Six-Thousand-Dollars (\$466,000.00)
 - City funds provided by the City shall be provided to finance the balance of the eligible participating project construction costs, 0%, estimated at Zero -Dollars (\$0.00). The CITY shall also provide 100% of any federally non-participating costs, estimated at Zero-Dollars (\$0.00). Total City funds are currently estimated at Zero-Dollars (\$0.00). The estimated City funds shall be placed on deposit with the DEPARTMENT upon execution of this agreement and receipt of the Department's invoice, prior to advertising the project for bid.
16. a) It is understood by the City and the Department that the funding participation stipulated herein may be altered due to bid prices, construction supervision costs and federally non- participating costs incurred during construction.
- b) The DEPARTMENT, using its own forces or the services of others, will supervise and inspect all work performed by the construction contractor and will provide such engineering, inspection and testing services as may be required to ensure that the construction of the project is accomplished in accordance with the approved PS&E. Actual supervision and inspection costs shall be charged to the project and financed as described in PARAGRAPH 15 of this agreement.
- c) The City will be responsible for payment of estimated local funding prior to advertising the project for bid. Upon final acceptance of this project, the amount of federal funds and the amount previously deposited by the City will be deducted from the total cost and a refund will be made by the Department to the City or additional funding will be requested from the City. The City agrees to make arrangements for payment of any Department invoice within 45 days of receipt.
17. It is understood by the City that only those DEPARTMENT administered funding sources specified in Paragraph 15 of this agreement shall be made available for the financing of this project. All other costs are the responsibility of the CITY. No STATE funds are allocated to this project.
18. Upon approval of this Agreement and the plans, specifications and estimates by the City, Department and the Federal Highway Administration, if applicable, the Department shall agree to advertise and let the contract for this project in the usual and customary legal manner. It is agreed that the project herein described is proposed to be financed as previously set forth, and that this Agreement, all plans, specifications, estimates of costs, acceptance of work, payments and procedures in general hereunder are subject in all things at all times to all federal laws, regulations, orders and approvals as may be applicable hereto.

19. The Department agrees to construct said project in strict accordance with the plans furnished and approved by the City, provided that upon consultation with and agreement by the City, the Department shall have the right to make such changes in the plans and specifications as are necessary for the proper construction of the project. The Department shall provide competent supervision at all times that the work is in progress. The City shall have inspectors on the project site as the City determines necessary to ensure construction of the project to the satisfaction of the City and shall have representatives available for consultation with the Department representatives to cooperate fully to the end of obtaining work strictly in accordance with the City's approved plans and specifications.
20. The City agrees that it will intervene as a party defendant in all actions where a contractor may allege delay due to failure of the City to accomplish timely utility relocations, site conditions which are not represented on the plans or plan errors which impact on project constructability, whether in the District Court or in an alternative dispute resolution forum, will defend all such actions and will pay all damages relating to delay as may be assessed by such court or alternative dispute resolution forum against the City for its adjudged failure.
21. Failure by the City to fulfill its responsibilities under this Agreement will disqualify the City from future participation in any Federal-aid project. Federal funds are to be withheld until such time as the deficiencies in regulations have been corrected or the improvements to be constructed under this Agreement are brought to a satisfactory condition of maintenance.
22. It is further specifically agreed between the City and the Department that the project will be built in accordance with the plans and specifications, and upon final acceptance by the City and the Department of this project, the City does hereby accept full, complete and total responsibility for maintenance of this project as provided in this Agreement. The City does not waive any rights against any contractor(s) with respects to defects, hidden or otherwise, in materials or workmanship. The City does not, pursuant to this provision or any other provision in this Agreement, waive its sovereign immunity or any exemption from, exception to or limitation of liability as provided in the Governmental Tort Claims Act.
23. The Secretary of the Department may terminate this Agreement in whole or, from time to time, in part whenever:
 - a. The requisite federal funding becomes unavailable through failure of appropriation or otherwise.
 - b. The contractor is prevented from proceeding with the work as a direct result of an Executive Order of the President with respect to the prosecution of war or in the interest of national defense or an Executive Order of the President or Governor of the State with respect to the preservation of energy resources.
 - c. The contractor is prevented from proceeding with the work by reason of a preliminary, special or permanent restraining order of a court of competent jurisdiction where the issuance of such order is primarily caused by the acts or omissions of persons or agencies other than the contractor.

- d. The Secretary determines that such termination is in the best interest of the State.

REMAINDER OF PAGE INTENTIONALLY BLANK

IN WITNESS WHEREOF, the Deputy Director of the Department of Transportation, pursuant to authority vested in him by the State Transportation Commission, has hereunto subscribed his name as Deputy Director of the Department of Transportation and the City has executed same pursuant to authority prescribed by law for the City.

The City, _____ on this __ of _____, 2019, and the Department on the __ day of _____, 2019.

The City of Midwest City,
an Oklahoma Municipal Corporation

Mayor

(SEAL)

ATTEST:

City Clerk

Approved as to Form and Legality:

City Attorney

STATE OF OKLAHOMA
DEPARTMENT OF TRANSPORTATION

Recommended for Approval

Local Government Division Manager

Director of Capital Programs

APPROVED AS TO FORM
AND LEGALITY

APPROVED

General Counsel

Deputy Director

OKLAHOMA DEPARTMENT OF TRANSPORTATION

INVOICE

Make check PAYABLE, and MAIL TO:

**Oklahoma Department of Transportation
 Comptroller Division
 200 N.E. 21st Street
 Oklahoma City, Oklahoma 73105-3204**

To: The City of Midwest City

Department Invoice No 33739(04)
 January 23, 2019

Description - Explanation of Charge	Quantity	Price Each	Total
Due Date: <u>Upon Receipt</u>			
Project Number: STPG-255F(482)AG Job Number: 33739(04)			
Total Estimated Cost including Inspection Cost:			\$466,000.00
Less Federal Share			(\$466,000.00)
Less Sponsor Initial Deposit			(\$ 0,00.00)
Local Share Due			<u>\$0.00</u>
Accounting Use Only		Invoice Total	\$0.00

Distribution:

City
 Remit with Payment
 Division Project File
 Comptroller Division



City of Midwest City Police Department

100 N. Midwest Boulevard

Midwest City, OK 73110

Office 405.739.1320

Fax 405.739.1398

Memorandum

TO: Honorable Mayor and City Council

FROM: Brandon Clabes, Chief of Police

DATE: February 12, 2019

RE: Discussion and consideration of declaring ninety seven (97) firearms of various calibers as surplus and authorizing their disposal by trade-in toward future purchases of with GT Distributors, Austin, Texas for a trade-in amount of \$7,010.00.

The attached list of firearms has been converted through the legal process. The Midwest City Police Department request consideration to enter into an agreement with GT Distributors of Austin, Texas to dispose of the converted firearms for a trade-in value of \$7,010.00. This will leave a \$7,010.00 credit for purchases with GT.

Staff recommends approval.

Brandon Clabes, Chief of Police

Attachments:



JAN 10 2019

IN THE DISTRICT COURT OF OKLAHOMA COUNTY OF
STATE OF OKLAHOMA

Case No. CP-2018-21

IN RE: APPLICATION OF CHIEF OF POLICE)
OF THE CITY OF MIDWEST CITY,)
OKLAHOMA, TO DISPOSE OF CERTAIN)
PERSONAL PROPERTY.)

CP-2018-21

ORDER

On the 10th day of January, 2019, this matter comes on for hearing. Applicant appears by City Prosecutor, Joanne Horn and Steven Hunter appears, but no others appeared. Applicant demonstrated proper notice, to all parties by posting and publication.

WHEREUPON, the Court having considered the pleadings, statements of counsel, and being fully advised in the premises, finds that Mr. Steven Hunter has shown adequate proof of ownership for the Taurus 709 Slim 9MM handgun, serial number TJT98225, taken from Mr. Alex Hunter when arrested.

IT IS THEREFORE ORDERED, ADJUDGED AND DECREED by this Court in regard to the firearms owned by felons, property of parties listed, for which the Chief of Police of the City of Midwest City has possession:

The Chief of Police for the City of Midwest City may release the above referenced handgun to Mr. Steven Hunter and is authorized, with respect to the remaining property listed, to:

1. Sell the listed property;
2. Convert the listed property to the use of the City of Midwest City;
3. Destroy the listed property;
4. Donate any property with a value of less than five hundred dollars (\$500.00), and
5. Deposit the moneys received from the sale of the property to the general fund of the City of Midwest City.

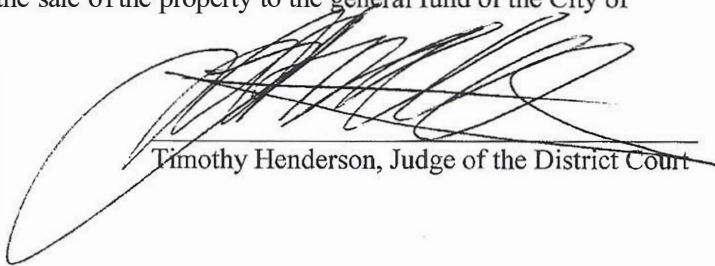
Timothy Henderson, Judge of the District Court

Approved:

Joanne Horn, OBA No. 21703

City Prosecutor of the City of Midwest City
100 N. Midwest Boulevard
Midwest City, Oklahoma 73110
(405) 739-1284
JHorn@MidwestCityOK.org

Steven Hunter

Steven R. Hunter

PROPERTY CONVERSION LIST						
CASE #	OFFENSE	DATE R'VD	PROPERTY	SERIAL #	STATUS	OWNER
11-09647	RECOVERED STOLEN PROPERTY	12/16/2011	APPLE IPAD 2	DN6GNH5XDFHY		UNKNOWN
12-02948	BURGLARY II AUTO	4/16/2012	NEXSTAR 43LT GPS UNIT	ML0904074195		UNKNOWN
13-05793	BURGLARY II RESIDENCE	7/18/2013	ELECTRONIC CONVERTER 2 XBOX CONTROLLERS	UNK	OWNER DID NOT PICK UP	SHAUN ERIC KELLEY
13-09455	POSSESSION OF CDS	11/25/2013	HP LAPTOP COMPAQ 8150P 120 GB HDD MICROSOFT XBOX 360 HARD DRIVE CALL OF DUTY BLACK OPS PS3 VIDEO GAME SONY PS3 GAME CONSOLE CALL OF DUTY GHOSTS PS3 VIDEO GAME	MXL84512FG CG218657775		UNKNOWN UNKNOWN UNKNOWN UNKNOWN
14-09038	BURGLARY II RESIDENCE	11/24/2014	BLU RAY PLAYER		OWNER DID NOT PICK UP	LESTER ROBBINS
14-09448	LARCENY OF COPPER	12/9/2014	MISC TOOLS, PICK , COME ALONG, SHOVELS, SLED		SEIZED	RYAN KYLE FRANTZ
15-00981	POSS CDS	2/5/2015	RYOBI DRILL KIT AND CASE WHITE GALAXY TAB 4	SM-T23ONU		UNKNOWN UNKNOWN
15-05313	POSS CDS	7/8/2015	APPLE IPAD MINI	DYTHHVC7DJ8R		UNKNOWN
15-05838	CONC STOLEN PROPERTY	7/26/2015	NEXTHOOK, NETBOOK DELL LAPTOP SONY PSP ACER LAPTOP SONY PSP, NO TAG WITH SERIAL NUMBER X BOX 360 W/TWO CONTROLLERS,	YFG0H?009S?? CN-OKH96S-70166-64M-G2AE HU3846426 LXR4G02060033178541601 RCPM11412-0920		UNKNOWN UNKNOWN UNKNOWN UNKNOWN UNKNOWN
15-06252	LARCENY OF MOTOR VEHICLE	8/9/2015	BAG CONTAINING MISC TOOLS BLUE BAG CONTAINING MISC TOOLS PLASTIC TOOL BOX WITHOUT LID WITH MISC TOOLS			UNKNOWN UNKNOWN UNKNOWN
15-06988	BURGLARY II AUTO	9/3/2015	BLACK GYM BAG WITH MISC CAR TOOLS			UNKNOWN
15-08309	BURGLARY II OTHER	10/19/2015	COINS FROM COIN COLLECTION 49 FOREIGN COINS			UNKNOWN
15-08670	PETIT LARCENY	11/1/2015	18 PIECE MAINSTAYS COOK SET			UNKNOWN
15-09646	HARBORING VENOMOUS SNAKES	12/8/2015	TWO SMALL SCREEN TOPPED ENCLOSED TERRARIUMS		SURRENDERED	MICHAEL KEITH GERMANN
16-00242	POSS STOLEN PROPERTY	1/11/2016	BAG OF MISC WATCHES 3 XBOX 360 GAMES HOYT COMPOUND BOW MISC TOOLS BAG OF SPOONS EMERSON TELEVISION MODEL LF501EM5F	DS1A429481180		UNKNOWN UNKNOWN UNKNOWN UNKNOWN UNKNOWN UNKNOWN
16-01103	IDENTIFY THEFT	2/11/2016	BOX WITH 2 HEADLIGHTS FOR TOYOTA AUTO FOG LAMPS AUTO OXYGEN SENSOR PAIR OF AUTO LIGHT HOUSINGS			UNKNOWN UNKNOWN UNKNOWN UNKNOWN

			AUTO COMPUTER MODULES			UNKNOWN
16-03421	FOUND PROPERTY	5/2/2016	HP LAPTOP	2CE3160G56H		UNKNOWN
16-03546	A&B WITH DANG WEAPON	5/6/2016	CRAFTSMAN CHAIN SAW WITH 18" BLADE		OWNER DID NOT PICK UP	PAUL BERUBE JR
16-03643	BURGLARY II AUTO	5/9/2016	YELLOW CONSTRUCTION LIGHT			UNKNOWN
			8 GB IPOD	YM903DT93QW		UNKNOWN
16-04419	TRAFFICKING CDS METH	6/4/2016	POOL CUE SET WITH BROWN ZIP UP POUCH			UNKNOWN
16-05000	BURGLARY II AUTO	6/25/2016	POLK SURROUND BAR 2000	AM120209048Q		UNKNOWN
			SONY PSP GAME SYSTEM	PP105974695-PSP1001		UNKNOWN
			POLAROID TABLET CASE W/ KEYBOARD			UNKNOWN
16-07977	BURGLARY II AUTO	10/16/2016	JVC GR-SXM260U VIDEO CAMERA	139Q8642		UNKNOWN
			BROWN GENEVA WRIST WATCH			UNKNOWN
			STRADA WRIST WATCH WITH LEATHER BAND			UNKNOWN
16-08979	INTERFERING	11/26/2016	CYNOCLARS VIRTUAL REALITY HEADSET		UNABLE TO LOCATE	BOIERI KVEC
16-09155	FOUND PROPERTY	12/3/2016	2"BALL 3 1/4 DROP TRAILER HITCH			UNKNOWN
16-09220	POSS STOLEN MOTOR VEHICLE	12/6/2016	MISC TOOLS, SOCKETS, JACKSTAND			UNKNOWN
			BLACK AND GREY BACK PACK			UNKNOWN
			KOBALT CORDLESS IMPACT DRIVER	5088		UNKNOWN
			FIRST AID BAG			UNKNOWN
16-09671	INJUR MOLEST STANDING AUTO	12/24/2016	2 SETS OF JUMPER CABLES			UNKNOWN
17-00490	FOUND PROPERTY	1/22/2017	STANLEY BRAND WRENCHES			UNKNOWN
			EXTREME BRAND VR VUEII REALITY VIEWER	8.05106E+11		UNKNOWN
			SANYO DIGITAL CAMERA	9051029858		UNKNOWN
			DRILLMASTER 3/8 REVERSIBLE DRILL	401537265		UNKNOWN
17-01864	POSS PARAPHERNALIA	3/13/2017	GARMIN GPS			UNKNOWN
			MOTOROLA HAND HELD DEVICE			UNKNOWN
			POSH TABLET			UNKNOWN
17-02091	FOUND PROPERTY	3/20/2017	LOREX DIGITAL VIDEO RECORDER	NDO11604006217		UNKNOWN
17-02221	FOUND PROPERTY	3/27/2017	HP FLYER LAPTOP	5CD6502DLC		UNKNOWN
17-02506	POSS PARAPHERNALIA	4/6/2017	HP STREAMBOOK LAPTOP	CD703311G	UNABLE TO LOCATE	STEPHANIE RAE PROCK
			BLACK ANDROID TABLET, UNKOWN BRAND OR SERIAL NUMBER			STEPHANIE RAE PROCK
			BLACK BACK PACK			STEPHANIE RAE PROCK
17-02848	FOUND PROPERTY	4/18/2017	ZYMA RADIO CONTROLLED DRONE			UNKNOWN
17-03506	BURGLARY 1ST DEGREE	5/14/2017	BLACK KINDLE TABLET			UNKNOWN
17-03579	FOUND PROPERTY	5/16/2017	3 LARGE BOXES OF FILTERS			UNKNOWN
17-04190	GENERAL ARREST	6/7/2017	BROWN BOX WITH VACUUM AND PARTS		UNABLE TO LOCATE	RENA LYNN PRENTICE

17-05256	FOUND PROPERTY	7/16/2017	CROCK POT			UNKNOWN
17-06642	LARCENY OF MOTOR VEHICLE	9/9/2017	CRAFTSMAN POWER BLOWER	UNKNOWN		UNKNOWN
			SPEEDAIRE AIR COMPRESSOR MODEL 4YN53	L12151999		UNKNOWN
			BLACK AND DECKER ELECTRTRIC SANDER	UNKNOWN		UNKNOWN
17-06756	FOUND PROPERTY	9/13/2017	HOME REPAIR TOOL SET			UNKNOWN
			DRILL BITS			
17-07092	FOUND PROPERTY	9/26/2017	BAG OF BROKEN WATCHES			UNKNOWN
			GLASS VANITY MIRROR			UNKNOWN
			DEWALT IMPACT DRIVER WITH CHARGER AND BATTERY			UNKNOWN
			SAMSUNG SUBWOOFER			
17-07639	FOUND PROPERTY	10/17/2017	LEATH POOL BAG			UNKNOWN
			SIR JOSEPH BLACK POOL GLOVE			UNKNOWN
			BROWN POOL CHALK HOLDER			UNKNOWN
			BLACK SCORPION POOL CUE			UNKNOWN
			TAN RANGE POOL CUE			UNKNOWN
17-07867	FOUND PROPERTY	10/20/2017	TENNIS RACKETS			UNKNOWN
17-08171	FOUND PROPERTY	11/8/2017	SILVER APPLE IPAD MINI			UNKNOWN
17-08274	FOUND PROPERTY	11/11/2017	SONY AMPLIFIER	1507532		UNKNOWN
18-01447	FOUND PROPERTY	3/6/2018	RING, 2 WATCHES, CAMERA, SPOOL OF CABLE			VARIOUS OWNERS
18-01494	FOUND PROPERTY	3/8/2018	LED LIGHT BAR			UNKNOWN
			JLAB SPEAKER			UNKNOWN
18-01804	FOUND PROPERTY	3/20/2018	BLACK AMAZON FIRE TABLET			UNKNOWN

Bicycle Conversion List

CASE #	OFFENSE	DATE R'VD	PROPERTY	SERIAL #	OWNER	
16-04880	ACCIDENT AUTO PED	6/21/16	TONY HAWK HUCKJAM SERIES		ANTONINETTE M GALLAHER	UNABLE TO LOCATE
16-06132	GENERAL ARREST	8/5/16	SPECIALIZED 10 SPEED	PV2M1725	JASON MATTHEW SWITCH	UNABLE TO LOCATE
16-07734	FOUND PROPERTY	10/6/16	HUFFY ARS MOUNTAIN BIKE	B99I059983	UNKNOWN	
16-07985	RESISTING/INTERFERWING WITH OFFICER	10/17/16	BLACK BICYCLE		ELIJAH BRICE JR.	UNABLE TO LOCATE
16-08027	BURGLARY II AUTO	10/18/16	MONGOOSE		AL-ESHA LEE	UNABLE TO LOCATE
17-00615	MALICIOUS INJURY OF PROPERTY	1/26/17	UNKNOWN MAKE MODEL BMX STYLE	FSD09GC9511	UNKNOWN	
17-00756	FOUND PROPERTY	1/31/17	GENESIS V2100 21 SPEED	GS32606WMA	UNKNOWN	
17-00926	FOUND PROPERTY	2/6/17	HUFFY BMX	SNHTZ15D00264	UNKNOWN	
17-00956	FOUND PROPERTY	2/7/17	TREK 220 MOUNTAIN BIKE	C79C9941	UNKNOWN	
17-01298	FOUND PROPERTY	2/19/17	HUFFY BMX STYLE DIAMONDBACK BMX STYLE KENT CRUISER MONGOOSE BMX STYLE	SNHYBC16G68977 DAA13E001922 CS151127680 SNACY11J04696	UNKNOWN UNKNOWN UNKNOWN UNKNOWN	
17-02165	FOUND PROPERTY	3/26/17	UNKNOWN SILVER FRAME BICYCLE	UNKNOWN	UNKNOWN	
17-02191	FOUND PROPERTY	3/27/17	MONGOOSE BMX STYLE	SNFD12C15314	UNKNOWN	
17-02240	FOUND PROPERTY	3/28/17	ROADMASTER MAXIMUM EDGE	RMC23253653	UNKNOWN	
17-02943	FOUND PROPERTY	4/22/17	MONGOOSE BMX STYLE	SNFSD15J66995	UNKNOWN	
17-03093	FOUND PROPERTY	4/28/17	WHITE 18 INCH BMX BICYCLE	UNKNOWN	UNKNOWN	
17-03195	FOUND PROPERTY	5/2/17	NEXT WIPEOUT	DJIH146218	UNKNOWN	
17-03359	FOUND PROPERTY	5/9/17	NEXT WIPEOUT BMX STYLE	DJIC140479	UNKNOWN	
17-03792	FOUND PROPERTY	5/24/17	OZONE 500 MOUNTAIN BIKE	DJHL014792	UNKNOWN	
17-03797	FOUND PROPERTY	5/24/17	NEXT MOUNTAIN BIKE	DJIA121085	UNKNOWN	
17-04042	FOUND PROPERTY	6/1/17	KENT BLUE AND WHITE BICYCLE		UNKNOWN	

17-04319	FOUND PROPERTY	6/11/17	NEXT SHOCKER MOUNTAIN BIKE	DM05F155196	UNKNOWN	
17-04634	FOUND PROPERTY	6/23/17	MONGOOSE BMX BLUE/GREEN MONGOOSE BMX BLUE/GREEN BMX STYLE WHITE CHAOS BMX STYLE GREEN		UNKNOWN UNKNOWN UNKNOWN UNKNOWN	
17-04779	FOUND PROPERTY	6/28/17	HUFFY 626 BMX STYLE	HID13F90313	UNKNOWN	
17-05269	FOUND PROPERTY	7/17/17	ROADMASTER GRANITE PEAKS	SNFSDL4BP1258	UNKNOWN	
17-05375	FOUND PROPERTY	7/21/17	PACIFIC NOMAD 3 SPEED	CB770159	UNKNOWN	
17-05459	FOUND PROPERTY	7/24/17	HYPER BIKE CO MOUNTAIN BIKE MAGMA BMX STYLE	DMG13K109625 DJHI097628	UNKNOWN UNKNOWN	
17-05627	FOUND PROPERTY	7/30/17	HUFFY STALKER ROADMASTER GRANITE PEAKS	HC7784626 5NFSD14G86542	UNKNOWN UNKNOWN	
17-05632	FOUND PROPERTY	7/31/17	KENT ABYSS BMX STYLE	GSS2090WMA	UNKNOWN	
17-05640	FOUND PROPERTY	7/31/17	KENT AMBUSH BMX STYLE	G1410016444	UNKNOWN	
17-05740	FOUND PROPERTY	8/4/17	MONGOOSE BYTE 20 "	R081526539	UNKNOWN	
17-05823	FOUND PROPERTY	8/7/17	OZONE BMX STYLE	1406100553	UNKNOWN	
17-05900	PETIT LARCENY	8/11/17	PACIFIC 10 SPEED		SHANA SUSETTE WARE	DID NOT PICK UP SFKPNG
17-05907	FOUND PROPERTY	8/11/17	MONGOOSE BMX STYLE	FSD0415AE	UNKNOWN	
17-06010	FOUND PROPERTY	8/16/17	ELK RIVER FS ELITE 21 SPEED	980704882	UNKNOWN	
17-06057	PETIT LARCENY	8/17/17	GENESIS V2100 MOUNTAIN BIKE	GS130705011	JOHNNY RANDEL WORRELL	DID NOT PICK UP SFKPNG
17-06086	FOUND PROPERTY	8/18/17	NEXT POWER X MOUNTAIN BIKE	LWCND33153	UNKNOWN	
17-06179	FOUND PROPERTY	8/22/17	TEMPO THRUSTER FREESTYLE	G1210076344	UNKNOWN	
17-06206	FOUND PROPERTY	8/23/17	CHAOS FS20 GREEN	GS520090WMA	UNKNOWN	
17-06508	FOUND PROPERTY	9/4/17	MONGOOSE 21 LEDGE MOUNTAIN BIKE	SNFSD14C28074	UNKNOWN	
17-07529	FOUND PROPERTY	10/12/17	SCHWINN SPITFIRE	SNOAB04M700I2	UNKNOWN	
17-07544	FOUND PROPERTY	10/13/17	HUFFY MOUNTAIN BIKE MONGOOSE XR 15 BLACK		UNKNOWN UNKNOWN	
17-08034	GENERAL ARREST	11/2/17	HUFFY BMX	SNHEF11HU3362	TYLER DAVID HOWARD	UNABLE TO LOCATE
17-08511	FOUND PROPERTY	11/22/17	KENT BMX STYLE	HS160603464	UNKNOWN	
17-09062	FOUND PROPERTY	12/14/17	ROADMASTER BMX STYLE SILVER	ACX6B06110	UNKNOWN	
18-00666	ACCIDENT W/ INJURY	1/31/18	NEXT BRAND MOUNTAIN BIKE	UNKNOWN	KIM DENISE BURNETT	DID NOT PICK UP SFKPNG

18-00980	FOUND PROPERTY	2/13/18	MONGOOSE BIKE RED/WHITE/BLACK	UNKNOWN	UNKNOWN
18-01292	FOUND PROPERTY	2/28/18	TANK BICYCLE UNKNOWN MAKE	UNKNOWN	UNKNOWN
18-01378	FOUND PROPERTY	3/3/18	18" TREK BIKE	WTU357C0206C	UNKNOWN
18-01769	FOUND PROPERTY	3/18/18	HUFFY NINJA TURTLE BICYCLE	SNFSD16C90916	UNKNOWN
18-02085	FOUND PROPERTY	3/30/18	ROCKIT 20" BIKE	2891450507	UNKNOWN
18-02168	MENTAL HEALTH TRANSPORT	4/3/18	UNK MAKE SPRAY PAINTED BICYCLE	HS160902965	UNKNOWN
18-02184	FOUND PROPERTY	4/3/18	BMX BIKE		UNKNOWN
18-02189	FOUND PROPERTY	4/3/18	MAGMA BIKE	8596-05 2003.9.24	UNKNOWN
18-02411	FOUND PROPERTY	4/12/18	HUFFY MOUNTAIN BIKE	AH17C151488	UNKNOWN
18-02770	FOUND PROPERTY	4/27/18	COREX MT 2000		UNKNOWN
18-02860	FOUND PROPERTY	4/30/18	WHITE RED RACER GO KART GREY RACER GO KART		UNKNOWN UNKNOWN

Case #	Offense	Date	Amount	Status	Owner
13-08466	ROBBERY BY 2 OR MORE	10/19/13	10.00	UNABLE TO LOCATE	JOSE ABIEL HERNANDEZ
15-06483	FOUND PROPERTY	8/16/15	188.00		UNKNOWN
16-03472	NO STATE DRIVER'S LICENSE	5/3/16	234.00		UNKNOWN
16-03949	GRAND LARCENY	5/19/16	36.10		UNKNOWN
16-04479	INTERFERING WITH AN OFFICER	6/7/16	0.10	DID NOT PICK UP	NOAH JAMES WOOD
16-05901	BURGLARY BUSINESS	7/27/16	3.32		UNKNOWN
16-07977	BURG II AUTO	10/16/16	5.91		UNKNOWN
16-08979	INTERFERING WITH AN OFFICER	11/26/16	5,000.98	UNABLE TO LOCATE	BARON SAVA
16-09746	POSS CDS	12/28/16	2.06	DID NOT PICK UP	MICHAEL SHANE JONS
17-00036	FOUND PROPERTY	1/2/17	17.00	UNABLE TO LOCATE	JOSEPHINE CHY KOKO
17-01420	POSS PARAPHERNALIA	2/24/17	5.00	UNABLE TO LOCATE	SHAWN CARL STYS
17-01870	FOUND PROPERTY	3/14/17	2.50		UNKNOWN
17-02155	FOUND PROPERTY	3/25/17	5.00		UNKNOWN
17-03125	FOUND PROPERTY	4/29/17	0.76	UNABLE TO LOCATE	ANN ALGER
17-03273	FOUND PROPERTY	5/5/17	53.03		UNKNOWN
17-04581	FOUND PROPERTY	6/21/17	56.20		UNKNOWN
17-04774	FOUND PROPERTY	6/28/17	2.00		UNKNOWN
17-06539	FOUND PROPERTY	9/5/17	10.00	UNABLE TO LOCATE	DAISY MARIE SHAFER
17-06670	FOUND PROPERTY	9/10/17	3.26		UNKNOWN
17-08722	FOUND PROPERTY	12/1/17	120.00		UNKNOWN

18-00442	FOUND PROPERTY	1/21/18	10.58		UNKNOWN
18-00535	FOUND PROPERTY	1/25/18	100.00	UNABLE TO LOCATE	BRITTANY HEY
18-01804	FOUND PROPERTY	3/20/18	118.00		UNKNOWN
			326.00		UNKNOWN
		TOTAL	6,309.80		

CASE #	OFFENSE	DATE RCVD	PROPERTY	STATUS	OWNER
16-04131	ROBBERY BY 2 OR MORE	5/25/2016	GOLD WATCH WITH DENIM STRAPS		UNKNOWN
16-09746	POSS CDS	12/28/2016	MISC COSTUME JEWELRY		UNKNOWN
17-00490	FOUND PROPERTY	1/22/2017	SILVER COLOR BRACELET HEART GOLD COLOR RING		UNKNOWN UNKNOWN
17-06201	FOUND PROPERTY	8/23/2017	YELLOW GOLD RING W/ 15 SMALL DIAMONDS YELLOW GOLD RING W 7 SMALL DIAMONDS		UNKNOWN UNKNOWN
17-06670	FOUND PROPERTY	9/10/2017	MISC COSTUME JEWELRY		UNKNOWN
18-01130	FOUND PROPERTY	2/20/2018	2009 HIGH SCHOOL CLASS RING	UTL	DEVIN RAY GARVIN
18-01519	DUI	3/8/2018	PINK WATCH	UTL	AMANDA GRISBY

Gun-Trade Eval. Form for:

Department:

Gp	Manufacturer	Model	Serial#	Caliber / Descr.	Part#	Contro	"Cost	B B Co!	Sights	Mags	Misc/Notes	Condition
	H POINT	C9	P1422448				30.00					FAIR
	H POINT	.380					30.00					FAIR
	GLOCK	21	CSR232				295.00					GOOD
	S&W	M457	VDL1376	45 CAL			205.00					FAIR
	STAR		32945	9MM			50.00					POOR
	KELTEC	P-11	36877	9MM			100.00					FAIR
	NAVY ARMS ORD		201467	BLKPWDR			20.00					POOR
	KELTEC	P-11	ATQ27	9MM			100.00					FAIR
	S&W	SD40VE	HEC7688	40CAL			145.00					GOOD
	JENNINGS	J-22	350584	22CAL			20.00					GOOD
	BRYCO		OBLITERATED	38			0.00					POOR
	FIE TITAN	TIGER	87516	38SPL			5.00					POOR
	SAM	M1911	M0150	45CAL			10.00					JUNK
		IML	295092	38CAL			5.00					POOR
	TAURUS	19	ANL230	9MM			100.00					FAIR
	ROCK ISLAND		RIA1030772				250.00					FAIR
	S&W	SW9VE	DW3917	9MM			145.00					GOOD
	COBRAY	M11	94-0032041	9MM			50.00					POOR
	S&W	M&P	CWY1855	38SPL			145.00					GOOD
	FIE TITAN	E15	25346	22CAL			5.00					JUNK
	GLOCK	MODEL30	PYB344	45CAL			\$295					GOOD
	KELTEC	P3AT	JS248				35					POOR
	SPRINGFIELD ARMORY	XDMXD9	XD225555	9MM			175					GOOD
	JBRYCO	38	294716	38			20					POOR
	RUGER	SR40	DEFACED	40CAL			2					POOR
	KAHR	CW45	SD4045	45			135					FAIR
	KELTEC		AA3432	9MM			115					FAIR
	JENNINGS	J-22	170028	22CAL			20					FAIR
	MGDTEX		ALTERED	22 CAL			2					JUNK
	S&W	M&PSHIELD	HPY8006	9MM			125					FAIR
	TAURUS	DASA	TGX14779	9MM			125					FAIR
	RUGER	P89	312-98109	9MM			145					FAIR
	BRYCO		795975	9MM			20					POOR
	ACCUTEK		14221	380CAL			35					POOR
	H POINT	C9	1928501	9MM			35					FAIR
	LLAMA	MINIMAX	07-04-15496-99	9MM			145					FAIR
	UNK	UNK	UNK	REVOLVER			2					JUNK
	SIG	SP2022	24B188195	40 CAL			200					GOOD
	F INDUSTRIEES		CPA01045	380CAL			20					POOR
	H POINT	JCP MODEL 40 SW	X7148814	40 CAL			10					POOR
	S&W	SW40VE	PAE8026	40 CAL			10					POOR
	S&W		KJM759D	380CAL			10					POOR
	JENNINGS		620289	380CAL			10					POOR
	PW ARMS	M1895	138677	38C			10					POOR
	SPRINGFIELD ARMORY	1911	NM468720	45 CAL			300					GOOD
	SPRINGFIELD ARMORY	XDS	XD514585	40CAL			185					FAIR

	S&W		AM62763	32CAL			20					POOR
	GLOCK	19	BAYD722	9MM			300					GOOD
	KAHR	CM9	1T1413	9MM			115					GOOD
	AMERICAN	REVOLVER	6089				2					JUNK
	HARRINGTON AND RICHARDSON		6673				2					JUNK
	RAVEN ARMS	P-25	UNK	25CAL			2					JUNK
	FIE TITAN	15 E	5708283	22CAL			2					JUNK
	TAURUS	PT111	TIU53969	9MM			115					GOOD
	LIBERTY	REVOLVER	101145	22CAL			2					JUNK
	TITAN	TIGER	522336	38CAL			2					POOR
	CLERKE	TEC	240313	22CAL			10					FAIR
	H POINT	MODEL C	P773262	380CAL			35					FAIR
	SPRINGFIELD ARMORY		N382873	45CAL			300					GOOD
	RUGER	BLACKHAWK	34-59851	357			250					GOOD
	RUGER	MKII	219-067869	22CAL			115					FAIR
	JENNINGS	BRYCO	482576	38CAL			10					JUNK
	INTERDYNAMIC	KG99	5520	9MM			20					POOR
	TAURUS	TCPPT788	83557B	380 CAL			20					POOR
	TAURUS	JUDGE	JU964045				250					FAIR
	COM	REVOLVER	UNK	22CAL			2					JUNK
	PAPM92	SBR	M92PV071026	7.62			300					GOOD
	SCCY INDUSTRIES	CPX-2	319721	9MM			115					FAIR
	INTRATEC	TEC22	36350	22CAL			125					FAIR
	LONG	GUNS					0					
							0					
	STEVENS	MODEL67	D804192	410 GA			40					FAIR
	MOSSBURG	23	K556683				20					FAIR
	ROSSI		SP284944	20GA			50					
	S.W.A.T	SF-15	SF-02240				20					JUNK
	MARLIN GLENFIELD	MODEL60	23319547				20					FAIR
	SAVAGE	AXIS	H811465				30					GOOD
	MOSSBURG	500	P364838	12GA			100					GOOD
	WESTERN FIELD	XNH-4800	PRE 1968	410 GA			5					POOR
	MARLIN		9723536	22CAL			5					POOR
	SEARS & ROEBUCK	MODEL200	273.2251	12GA			2				FIRE DAMAGE	JUNK
	UNKBLKPWDR		00226_6				2				FIRE DAMAGE	JUNK
	TRADITIONS	BOLT ACTION	14-13-016496-98	50CAL			2				FIRE DAMAGE	JUNK
	UNKBLKPWDR		191622	50CAL			2				FIRE DAMAGE	JUNK
	MOSSBURG	MODEL 190		16GA			2				FIRE DAMAGE	JUNK
	MOSSBURG	MODEL 173		410 GA			2				FIRE DAMAGE	JUNK
	REMINGTON	MODEL597	A2615411				2				FIRE DAMAGE	JUNK
86	CONNECTCUT VALLEY		61-13-043064-97	50CAL			2				FIRE DAMAGE	JUNK
87	MARLIN	LEVER ACTION	10424				2				FIRE DAMAGE	JUNK
88	TAURUS	R92RH	M174301				2				FIRE DAMAGE	JUNK
	STEVENS ARMS	MODEL235	371581760	SG=Shotgun			2				FIRE DAMAGE	JUNK
	WINCHESTER		UNK	12GA			2				FIRE DAMAGE	JUNK
89	WINCHESTER		865788	30-06			250					GOOD
90	SPRINGFIELD	18C	A233178	410GA			2					JUNK
91	MAVERICK	MODEL88	OBLITERATED	12GA			30					POOR
92	BUSHMASTER	AR-15	BK1004247				325					FAIR

143												
144												
145												
146												
147												
148												
149												
150												
151												
152												
153												
154												
155												

Worksheet Totals: #REF!

SubTotal: \$0

P=P1stol
R=Revolver
SG=Shotgun
LG=Rifle

NS=Nfght Sights
BS=Bead Sights
RS=Rifle Sights
PS=Pistol Sights
AJ=Adj. Sights

E"Excellent
VG=Very Gooc
G=Good
F=Fair
P=Poor
J=Junk

At Pickup from Dept: GT Signature: Dept. Signature: Date:

At G T Warehouse Road Sales: Dept. Contact & Number: Warehouse Receiver: Date: 11/1/2010

 = Do Not Fill Out Red Cells/Blocks, internal for GT Rep. to finish



Information Technology
100 N. Midwest Boulevard
Midwest City, OK 73110
Office 405.739.1374
Fax 405.869.8602

MEMORANDUM

TO: Honorable Mayor and City Council

FROM: Ryan Rushing, Information Technology Director

DATE: February 12, 2019

SUBJECT: Discussion and consideration of 1) declaring various computer equipment obsolete items of city property on the attached list surplus; and 2) authorizing their disposal by public auction or sealed bid.

The following computer equipment and peripheral devices are obsolete, defective or have been replaced.

Staff recommends approval

Ryan Rushing, Information Technology Director



Information Technology
 100 N. Midwest Boulevard
 Midwest City, OK 73110
 Office 405.739.1374
 Fax 405.869.8602

CPU			
INVENT #	MIS#	MANUFACTOR	SERIAL NUMBERS
1982		Samsung Cloud stand base	ZWYSHTSF500038H
	632	Dell Optiplex 380	87RPQL1
	754	Dell Optiplex 390	H6PLLS1
	752	Dell Optiplex 390	H6NRLS1
	753	Dell Optiplex 390	H6NPLS1
	914	Dell Optiplex 3010	8Y6BFX1
	916	Dell Optiplex 3010	3TFSFX1
	869	General Dynamics GD6000	ZZSJC1294ZZ0021
	870	General Dynamics GD6000	ZZSJC1294ZZ0031
	842	General Dynamics GD6000	ZZSJC1273ZZ0028
	852	General Dynamics GD6000	ZZSJC1273ZZ0016
	866	General Dynamics GD6000	ZZSJC1294ZZ0040
	579	Dell Optiplex 360	807PMJ1
		Dell inspiron mini 1012	8FKJ2L1
		Dell inspiron mini 1012	JN263L1
MONITORS			
INVENT #	MIS #	MANUFACTURE	SERIAL NUMBERS
	548	Dell	CN-06H6FX-74445-217-556L
	528	Dell	CN-06H7FX74445-217-A84L
	379	Dell	CN-0F180G-64180-92R-2LDL
MISCELLANEOUS			
Quantity	MIS #	Hardware Type	Serial Number
1		ZoNet 24 port switch	AI07X000208
1	1088	iPad Air 2	DLXNK77FG5YL
1	1028	iPad 4	DMPK2CFKF18W
1	1927	iPad Pro	DLXR94V8GMW3
1		HP 4050	USQC002837
		Adjustable Desk With Drawers	
		Small Desk Piece with Overhead	



DISCUSSION ITEMS





Memorandum

TO: Honorable Mayor and Council

FROM: Sara Hancock, City Clerk

DATE: February 12, 2019

SUBJECT: Consider the award of the sale of General Obligation Bonds of the City of Midwest City, Oklahoma, in the amount of Twenty Million and no/100s dollars (\$20,000,000.00) to the lowest bidder.

In accordance with Title 62, Oklahoma Statutes, 2011, Section 354, as amended, notice was given that the City of Midwest City, Oklahoma (the "Issuer") would received sealed written bids and electronic bids on Tuesday, February 12, 2019 at 10:30 a.m., local time at the Office of the City Clerk, City Hall, 100 North Midwest Boulevard, Midwest City, Oklahoma for the sale of all, but not less than all of \$20,000,000.00 aggregate principal amount of its General Obligation Bonds, Series 2019 (the "Series 2019 Bonds") which Series 2019 Bonds will mature \$795,000.00 in two years from their date and \$835,000.00 annually each thereafter until paid.

Action is necessary to sale the bonds.

These documents will be completed after the opening of the bids for the sale of the bonds at 10:30 am on February 12, 2019. Completed original documents will be provided to Council at the meeting.

Staff recommends approval.

Sara Hancock
Sara Hancock, City Clerk

**THE CITY COUNCIL OF THE CITY OF MIDWEST CITY, STATE OF OKLAHOMA,
MET IN REGULAR SESSION IN THE COUNCIL CHAMBERS AT THE CITY HALL, 100
NORTH MIDWEST BOULEVARD, IN SAID CITY ON THE 12TH DAY OF FEBRUARY,
2019, AT 6:00 O'CLOCK P.M.**

PRESENT:

ABSENT:

Notice of the regular meetings of the City Council for calendar year 2019 having been given in writing to the City Clerk of Midwest City, Oklahoma prior to December 15, 2018, and public notice having been posted in prominent public view at the City Hall, 100 North Midwest Boulevard, Midwest City, Oklahoma, twenty-four (24) hours prior to this meeting, excluding Saturdays, Sundays and legal holidays, all in compliance with the Oklahoma Open Meeting Act.

(OTHER PROCEEDINGS)

It appearing that due and legal notice had been given that the City of Midwest City, Oklahoma, would offer for sale on this date and at this hour and at this place its \$20,000,000.00 of General Obligation Bonds, Series 2019, maturing \$795,000.00 in two years from their date and \$835,000.00 annually each year thereafter until paid, the governing body of the City proceeded to consider the bids received for the purchase of said Bonds. The following bids were received and considered by the governing body of the City:

<u>BIDDERS</u>	<u>TRUE INTEREST RATE BID</u>	<u>PREMIUM</u>
----------------	-----------------------------------	----------------

The governing body of the City required each bidder to submit with his bid a sum in cash or its equivalent equal to two percent of his bid, and after due consideration of all bids received by the governing body, a motion was made by _____ that the bonds were awarded, sold, and delivered to _____, upon fulfillment of the terms set out in said contract and bid for the purchase of said Bonds. Said motion was seconded by _____, and was adopted by the following vote:

AYE:

NAY:

ADOPTED AND APPROVED this 12th day of February, 2019.

Mayor

ATTEST:

SARA HANCOCK, City Clerk

(SEAL)

APPROVED as to form and legality this 12th day of February, 2019.

HEATHER POOLE, City Attorney

I, the undersigned, the duly qualified and acting Clerk of the City of Midwest City, Oklahoma hereby certify that the foregoing is a true and complete copy of the proceedings of the governing body of said City at the time bids were reviewed and considered for the sale of its general obligation bonds, taken at a regular meeting thereof duly held on the date therein set out, as the same appears of record in my office.

I hereby certify that a true and complete copy of the Public Notice, attached hereto as Exhibit "A", was posted in prominent public view at the city Hall, 100 North Midwest Boulevard, Midwest City, Oklahoma, twenty-four (24) hours prior to the date of the meeting therein described, excluding Saturdays, Sundays and legal holidays. I further certify that a true, correct and complete copy of the schedule of regularly scheduled meetings of the City Council of the City for calendar year 2019 was filed in the office of the City Clerk of Midwest City, Oklahoma, as proscribed by law and in accordance with the Oklahoma Open Meeting Act.

WITNESS my hand and seal this 12th day of February, 2019.

(SEAL)

City Clerk



Memorandum

TO: Honorable Mayor and Council

FROM: Sara Hancock, City Clerk

DATE: February 12, 2019

SUBJECT: Consider and adopt an ordinance providing for the issuance of General Obligation Bonds in the sum of Twenty Million and No/100S dollars (\$20,000,000.00) by the City of Midwest City, Oklahoma authorized at an election duly called and held for such purpose; prescribing form of bonds; providing for registration thereof; providing for a system of registration for uncertificated registered public obligations; providing levy of an annual tax for payment of principal and interest on the same; fixing other details of the issue; and declaring an emergency.

This action is necessary to issue the bonds. Staff recommends approval.

Sara Hancock
Sara Hancock, City Clerk

**THE CITY COUNCIL OF THE CITY OF MIDWEST CITY, STATE OF OKLAHOMA,
MET IN REGULAR SESSION IN THE COUNCIL CHAMBERS AT THE CITY HALL, 100
NORTH MIDWEST BOULEVARD, IN SAID CITY ON THE 12TH DAY OF FEBRUARY,
2019, AT 6:00 O'CLOCK P.M.**

PRESENT:

ABSENT:

Notice of the regular meetings of the City Council for calendar year 2019 having been given in writing to the City Clerk of Midwest City, Oklahoma prior to December 15, 2018, and public notice having been posted in prominent public view at the City Hall, 100 North Midwest Boulevard, Midwest City, Oklahoma, twenty-four (24) hours prior to this meeting, excluding Saturdays, Sundays and legal holidays, all in compliance with the Oklahoma Open Meeting Act.

(OTHER PROCEEDINGS)

THEREUPON, an Ordinance was introduced which was read in full by the Clerk and considered by sections. Upon motion by _____, seconded by _____ the Ordinance was finally passed with the following vote:

AYE:

NAY:

And upon motion of _____, seconded by _____, the question of the emergency was ruled upon separately and approved by the following vote.

AYE:

NAY:

THEREUPON, the Ordinance was signed by the Mayor, attested by the Clerk, sealed with the seal of said municipality and is as follows:

ORDINANCE NUMBER _____

AN ORDINANCE PROVIDING FOR THE ISSUANCE OF GENERAL OBLIGATION BONDS IN THE SUM OF TWENTY MILLION AND NO/100S DOLLARS (\$20,000,000.00) BY THE CITY OF MIDWEST CITY, OKLAHOMA AUTHORIZED AT AN ELECTION DULY CALLED AND HELD FOR SUCH PURPOSE; PRESCRIBING FORM OF BONDS; PROVIDING FOR REGISTRATION THEREOF; PROVIDING FOR A SYSTEM OF REGISTRATION FOR UNCERTIFICATED REGISTERED PUBLIC OBLIGATIONS; PROVIDING LEVY OF AN ANNUAL TAX FOR PAYMENT OF PRINCIPAL AND INTEREST ON THE SAME; FIXING OTHER DETAILS OF THE ISSUE; AND DECLARING AN EMERGENCY.

WHEREAS, on the 28th day of August, 2018, pursuant to notice duly given, an election was held in the City of Midwest City, State of Oklahoma, for the purpose of submitting to the registered, qualified electors of said City the question of the issuance of the bonds of said City in the following amounts:

\$15,965,000.00 of General Obligation Bonds by the City of Midwest City, Oklahoma, to provide funds (either with or without state or federal aid) for the purpose of constructing, reconstructing, improving, and repairing streets within said City, as authorized by Section 27, Article X of the Constitution and Statutes of the State of Oklahoma, and acts complementary, supplementary and enacted pursuant thereto; and

\$21,635,000.00 of General Obligation Bonds by the City of Midwest City, Oklahoma, to provide funds (either with or without state or federal aid) for the purpose of purchasing, constructing, equipping, improving, extending, renovating, repairing and beautifying public parks and parklands, cultural and recreational facilities, all to be owned exclusively by said City, as authorized by Section 27, Article X of the Constitution and Statutes of the State of Oklahoma, and acts complementary, supplementary and enacted pursuant thereto; and

\$10,490,000.00 of General Obligation Bonds by the City of Midwest City, Oklahoma, to provide funds (either with or without state or federal aid) for the purpose of acquiring, constructing, reconstructing, improving, remodeling, and repairing public safety buildings and facilities and acquiring necessary lands therefor and purchasing and installing public safety equipment all to be owned exclusively by said City, as authorized by Section 27, Article X of the Constitution and Statutes of the State of Oklahoma, and acts complementary, supplementary and enacted pursuant thereto; and

WHEREAS, as shown by the canvass of the returns by the County Election Board of Oklahoma County, Oklahoma, at said August 28, 2018 election there were cast by the registered, qualified electors of said City:

On the question of the issuance of said streets bonds, 7075 votes, of which 4,425 were in favor of and 2,650 were cast against the issuance of said bonds, and 0 were mutilated, spoiled or not voted ballots; and

On the question of the issuance of said parks bonds, 7065 votes, of which 3,580 were in favor of and 3,485 were cast against the issuance of said bonds, and 0 were mutilated, spoiled or not voted ballots; and

On the question of the issuance of said public safety bonds, 6,694 votes, of which 3,690 were in favor of and 3004 were cast against the issuance of said bonds, and 0 were mutilated, spoiled or not voted ballots; and

WHEREAS, a lawful majority of the registered, qualified electors voting on such Proposition cast their ballots in favor of the issuance of all of said bonds and the issuance thereof has been duly authorized; and

WHEREAS, the City of Midwest City, Oklahoma has not previously issued general obligation bonds for the above propositions; and

WHEREAS, The Council of the City of Midwest City, Oklahoma, pursuant to Title 62, Oklahoma Statutes 2011, Section 354, desires to issue at this time \$20,000,000.00 in General Obligation Bonds authorized at the August 28, 2018 election consisting of a combined issue of \$7,945,000.00 bonds for the purpose of constructing, reconstructing, improving, and repairing streets within said City; \$4,345,000.00 bonds for the purpose of purchasing, constructing, equipping, improving, extending, renovating, repairing and beautifying public parks and parklands, cultural and recreational facilities, all to be owned exclusively by said City; and \$7,710,000.00 bonds for the purpose of acquiring, constructing, reconstructing, improving, remodeling, and repairing public safety buildings and facilities and acquiring necessary lands therefor and purchasing and installing public safety equipment all to be owned exclusively by said City.

BE IT ORDAINED BY THE COUNCIL OF THE CITY OF MIDWEST CITY, OKLAHOMA:

SECTION 1. That there are hereby ordered and directed to be issued the bonds of said City, in accordance with the form as hereinafter set out, in the aggregate amount of Twenty Million and No/100s Dollars (\$20,000,000.00), which Bonds shall be designated "General Obligation Bonds, Series 2019" (the "Bonds"), shall be dated April 1, 2019, and shall become due and payable and shall bear interest from their date until paid as follows:

<u>Maturing April 1</u>	<u>Principal Amount</u>	<u>Interest Rate</u>
2021	\$795,000.00	.%
2022	\$835,000.00	.%
2023	\$835,000.00	.%
2024	\$835,000.00	.%
2025	\$835,000.00	.%
2026	\$835,000.00	.%
2027	\$835,000.00	.%
2028	\$835,000.00	.%
2029	\$835,000.00	.%

2030	\$835,000.00	.%
2031	\$835,000.00	.%
2032	\$835,000.00	.%
2033	\$835,000.00	.%
2034	\$835,000.00	.%
2035	\$835,000.00	.%
2036	\$835,000.00	.%
2037	\$835,000.00	.%
2038	\$835,000.00	.%
2039	\$835,000.00	.%
2040	\$835,000.00	.%
2041	\$835,000.00	.%
2042	\$835,000.00	.%
2043	\$835,000.00	.%
2044	\$835,000.00	.%

Interest shall be payable semi-annually on the first day of April and October of each year, commencing on April 1, 2020. The Bonds are issuable as registered Bonds in denominations of \$1,000.00 or any whole multiple thereof.

The Bonds maturing in the years 2021 through 2029, inclusive, shall not be subject to redemption prior to maturity. The Bonds maturing in the years 2030 and thereafter shall be subject to redemption at the option of the City, in whole or in part, in inverse order of maturity and by lot within a maturity, on any date on or after April 1, 2029, at the principal amount thereof plus accrued interest to the date fixed for redemption.

Notice of any such redemption shall be sent by registered or certified mail not less than thirty (30) days nor more than sixty (60) days prior to the date fixed for redemption to the Registered Holder of each Bond to be redeemed at the address shown on the Registration Books of the City maintained by the Registrar or at such other address as is furnished in writing by such Registered Holder to the Registrar. When so called for redemption, this Bond will cease to bear interest on the specified redemption date, provided funds for redemption are on deposit at the place of payment at that time, and shall not be deemed to be outstanding.

SECTION 2. That each of said Bonds and the endorsements and certificates thereon shall be in substantially the following form:

Unless this Bond is presented by an authorized representative of The Depository Trust Company to the Registrar for registration of transfer, exchange or payment and any bond issued is registered in the name of Cede & Co., or such other name as requested by an authorized representative of The Depository Trust Company and any payment is made to Cede & Co., ANY TRANSFER, PLEDGE OR OTHER USE HEREOF FOR VALUE OR OTHERWISE BY OR TO ANY PERSON IS WRONGFUL since the registered owner hereof, Cede & Co., has an interest herein.

No. _____
_____ %
UNITED STATES OF AMERICA
STATE OF OKLAHOMA
CITY OF MIDWEST CITY
General Obligation Bond, Series 2019
Due April 1, _____
\$ _____
CUSIP No. _____

KNOW ALL MEN BY THESE PRESENTS:

That the City of Midwest City, of Oklahoma County, Oklahoma, hereby acknowledges itself indebted to and for value received, promises to pay the principal amount set forth above to the person named below:

CEDE & CO., INC.

or registered assigns, (hereinafter called the "Registered Holder"), for the bond number(s) set forth above, together with interest thereon at the rate specified hereon, from the date hereof until paid, payable semi-annually on the 1st day of April, and the 1st day of October, respectively, in each year, beginning April 1, 2020.

The principal of and interest on this Bond are payable in lawful money of the United States of America which, at the time of payment, shall be legal tender for the payment of public and private debts. Payments of interest hereon shall be paid by check of BancFirst, Oklahoma City, Oklahoma (herein called the "Bank") payable to the order of the Registered Holder and mailed to the address shown in the Registered Holder on or before the date on which each such payment is due. Payment of principal of this Bond shall be payable only upon surrender of this Bond to the Bank.

THE FULL FAITH, CREDIT, AND RESOURCES of said City are hereby irrevocably pledged to the payment of this Bond.

THIS BOND is one of an issue of like date and tenor, except as to date of maturity, rate of interest, and denomination, totaling the principal sum of Twenty Million and No/100s Dollars (\$20,000,000.00) consisting of a combined issue of \$7,945,000 bonds for the purpose of constructing, reconstructing, improving, and repairing streets within said City; \$4,345,000.00 bonds for the purpose of purchasing, constructing, equipping, improving, extending, renovating, repairing and beautifying public parks and parklands, cultural and recreational facilities, all to be owned exclusively by said City; and \$7,710,000.00 bonds for the purpose of acquiring, constructing, reconstructing, improving, remodeling, and repairing public safety buildings and facilities and acquiring necessary lands therefor and purchasing and installing public safety equipment all to be owned exclusively by said City; all as approved at an election held on August 28, 2018; all pursuant to Section 27, Article X of the Constitution and statutes of the State of Oklahoma, and acts complementary, supplementary, and enacted pursuant thereto.

No person shall be entitled to any right or benefit provided in this Bond unless the name of such person is registered by the Bank as the Registrar of the City on the Registration Record. This Bond shall be transferable only upon delivery of this Bond to the Registrar, duly endorsed or

accompanied by a written instrument of transfer in form satisfactory to the Bank, duly executed by the Registered Holder hereof or his attorney duly authorized in writing, and such transfer registered on the Registration Record. The Registrar shall not be required to make such transfer after the fifteenth (15) day preceding any interest payment date (the "Record Date") until after said interest payment date. The name of the Registered Holder endorsed hereon shall be deemed the correct name of the owner of this Bond for all purposes whatsoever. The Registrar will keep the Registration Record open for registration of ownership of registered Bonds during its business hours. In the event of a change of Registrar for any reason, notice thereof shall be mailed, by registered or certified United States Mail, postage prepaid, to the Registered Holder at the address shown in the Registration Record, and such notice shall be effective on the date of mailing and sufficient as to all persons.

Bonds of the issue of which this Bond is one, maturing in the years 2021 through 2029, inclusive, shall not be subject to redemption prior to maturity. Said Bonds maturing in the years 2030 and thereafter shall be subject to redemption at the option of the City, in whole or in part, in inverse order of maturity and by lot within a maturity, on any date on or after April 1, 2029, at the principal amount thereof plus accrued interest to the date fixed for redemption.

Notice of any such redemption shall be sent by registered or certified mail not less than thirty (30) days nor more than sixty (60) days prior to the date fixed for redemption to the Registered Holder of each Bond to be redeemed at the address shown on the Registration Books of the City maintained by the Registrar or at such other address as is furnished in writing by such Registered Holder to the Registrar. When so called for redemption, this Bond will cease to bear interest on the specified redemption date, provided funds for redemption are on deposit at the place of payment at that time, and shall not be deemed to be outstanding.

IT IS HEREBY CERTIFIED AND RECITED that all acts, conditions and things required to be done, precedent to and in the issuance of this Bond have been properly done, happened and been performed in regular and due form and time as required by law, and that the total indebtedness of said City, including this Bond, and the series of which it forms a part, does not exceed any constitutional or statutory limitation; and that due provision has been made for the collection of an annual tax sufficient to pay the interest on this Bond as it falls due and also to constitute a sinking fund for the payment of the principal hereof at maturity.

IN WITNESS WHEREOF, said City has caused this Bond to be signed by the Mayor, attested by its City Clerk, and sealed with the seal thereof this 1st day of April, 2019.

Mayor of the City of Midwest City, Oklahoma

Attest:

City Clerk, City of Midwest City, Oklahoma
(Seal)

FORM OF ASSIGNMENT

The following abbreviations, when used in the inscription on the face of this Bond, shall be construed as though they were written out in full according to applicable laws or regulations:

TEN COM-- as tenants in common
TEN ENT-- as tenants by the entireties
JT TEN-- as joint tenants with the right of survivorship
 and not as tenants in common

UNIF GIFT MIN ACT--_____ Custodian for _____ under Uniform
 (Cust) (Minor)
 Gifts to Minors Act of Oklahoma

Additional abbreviations may also be used though not in above list.

ASSIGNMENT

FOR VALUE RECEIVED, the undersigned hereby sells, assigns and transfers unto _____

(Please insert Social Security or Taxpayer identification number of assignee)_____

(Please Print or Typewrite Name and Address of Assignee)

the within Bond, and all rights thereunder, and hereby does irrevocably constitute and appoint _____ attorney to transfer the within Bond on the books kept for registration thereof, with full power of substitution in the premises.

Dates: _____

(Signature guaranty)

NOTICE: The signature to this assignment must correspond with the name as it appears upon the face of the within Bond in every particular, without alteration or enlargement or any change whatever.

Legal Opinion
(ENDORSEMENT NO. 2)

Form of certificate by the City Treasurer to be endorsed on each Bond.

STATE OF OKLAHOMA)
) ss.
COUNTY OF OKLAHOMA)

I, the undersigned, the duly qualified and acting Treasurer of the within named City in said County and State, hereby certify that I have duly registered the within Bond in my office on this 1st day of April, 2019.

WITNESS my hand the date above written.

City Treasurer

(ENDORSEMENT NO. 3)

Certificate of approval by the Attorney General to be endorsed on each Bond.

STATE OF OKLAHOMA
OFFICE OF THE ATTORNEY GENERAL
BOND DEPARTMENT _____, 2019.

I HEREBY CERTIFY that I have examined a certified copy of the record of proceedings taken preliminary to and in the issuance of the within Bond; that such proceedings and such Bond show lawful authority for the issue and are in accordance with the forms and method of procedure prescribed and provided by me for the issuance of Bonds of like kind and that said Bond is a valid and binding obligation, according to its tenor and terms and, under the provisions of Title 62, Oklahoma Statutes 2011, Section 11, 13, and 14, requiring the certificate of the Bond Commissioner of the State of Oklahoma thereon, is incontestable in any court in the State of Oklahoma unless suit thereon shall be brought in a court having jurisdiction of the same within thirty days from the date of this approval of said Bond appearing in the caption hereto.

**Attorney General, Ex-Officio Bond
Commissioner of the State of Oklahoma**

SECTION 3. That each of said Bonds shall be signed by the Mayor and the corporate seal of the City affixed thereto and attested by the City Clerk of the City; that such officers be and hereby are authorized and directed to cause said Bonds to be prepared and to execute the same for and on behalf of the City, have the same registered by the Treasurer, endorsed by the District Attorneys and County Clerks and presented to the Attorney General, Ex-Officio Bond Commissioner, together with a certified transcript of all proceedings had in connection with their issue for his approval and endorsement; that thereafter said Bonds shall be delivered to the purchaser upon payment of the purchase price thereof, which shall not be less than par and accrued interest. The proceeds derived from the sale of said Bonds shall be placed in a special fund and used solely for the purposes set out in the Bond in Section 2 hereof.

SECTION 4. Whenever any registered Bond or Bonds shall be exchanged for another registered Bond or Bonds of different denomination, the Registrar shall cancel the Bond or Bonds surrendered in such exchange on the face thereof and on the Registration Record. If the supply of registered Bonds for making exchanges shall have been exhausted, the Registrar shall cause additional registered Bonds to be prepared, at the expense of the City. The City covenants that upon request of the Registrar, its appropriate officers promptly will execute such additional registered Bonds on behalf of the City.

SECTION 5. The Registrar for all registered Bonds issued pursuant to this Ordinance shall be BancFirst, Oklahoma City, Oklahoma, which shall maintain a Registration Record for the purpose of registering the name and address of the Registered Holder of each registered Bond. The Registrar will keep the Registration Record open for registrations during its business hours. In the event of a change of Registrar, notice thereof shall be mailed, registered or certified United State Mail, postage prepaid, to the Registered Holder of each registered Bond. The name and address of the Registered Holder as the same appear on the Registration Record shall be conclusive evidence to all persons and for all purposes whatsoever and no person other than the Registered Holder shown on the Registration Record shall be entitled to any right or benefit in relation to the Bond so registered; provided, that the foregoing shall not apply to any successor by operation of law of such Registered Holder. Registered Bonds shall be transferable only upon delivery of such Bonds to the Registrar, duly endorsed or accompanied by a written instrument of transfer in form satisfactory to the Registrar, executed by the Registered Holder thereof or his attorney duly authorized in writing, and such transfer registered on the Registration Record. If the Form of Assignment on such Bonds is exhausted, such Registered Bonds delivered to the Registrar for registration of transfer shall be canceled by the Registrar on the face thereof and the Registrar shall authenticate and deliver to the transferee Bonds in aggregate principal amount equal to the unpaid principal of the surrendered Bonds in new registered Bonds, in denominations of \$1,000.00 or any multiples thereof. The Registrar shall not be required to make such transfer after the fifteenth (15th) day preceding any interest payment date until after said latter date.

SECTION 6. There is hereby created and established a system of registration for uncertificated registered public obligations with respect to the Bonds as provided in the Registered Public Obligations Act of Oklahoma, Title 62, Oklahoma Statutes 2011, Section 582(13)(b), whereby books shall be maintained on behalf of the City by The Depository Trust Company, New York, New York, for the purpose of registration of transfer of the uncertificated registered public obligations with respect to the Bonds which specify the persons entitled to the uncertificated registered public obligations with respect to the Bonds and the rights evidenced thereby and which provide that the transfer of the uncertificated registered public obligations with respect to the Bonds and the rights evidenced thereby shall be registered upon such books, and the Mayor and City Clerk are hereby authorized and directed to execute such documents and instruments as may be required to implement the foregoing system of registration.

SECTION 7. That beginning with the year 2019, a continuing annual tax sufficient to pay the interest on said Bonds when due and for the purpose of providing a sinking fund with which to pay the principal of said Bonds when due shall be and is hereby ordered levied upon all taxable property in said City, in addition to all other taxes, said sinking fund to be designated "**GENERAL OBLIGATION BONDS, SERIES 2019, SINKING FUND.**" Said Tax shall be and is hereby

ordered certified, levied and extended upon the rolls and collected by the same officers, in the same manner and at the same time as the taxes for general purposes in each of said years are certified, levied, extended and collected; that all funds derived from said tax shall be placed in said sinking fund which, together with any interest collected on same, shall be irrevocably pledged to the payment of the interest on and principal of said Bonds when and as the same fall due.

SECTION 8. The City covenants and agrees that it shall at all times perform all acts and things necessary or appropriate under any valid provision of law to ensure that interest paid on the Bonds shall not be included in gross income of the owners thereof for Federal income tax purposes under the Internal Revenue Code of 1986, as amended.

SECTION 9. That by reason of the City of Midwest City being without adequate streets, parks and recreational facilities, and public safety facilities and equipment, it is deemed and hereby declared necessary for the preservation of the public health, peace and safety that this Ordinance shall become operative immediately; wherefore, an emergency is hereby declared to exist, and this Ordinance shall be in full force and effect immediately from and after its passage and approval.

ADOPTED AND APPROVED this 12th day of February, 2019.

ADOPTED AND APPROVED as an emergency measure this 12th day of February, 2019.

Mayor

ATTEST:

SARA HANCOCK, City Clerk

(SEAL)

APPROVED as to form and legality this 12th day of February, 2019.

HEATHER POOLE, City Attorney

I, the undersigned, the duly qualified and acting City Clerk of the City of Midwest City, Oklahoma hereby certify that the foregoing is a true and complete copy of an Ordinance authorizing the issuance of general obligation bonds for the purpose therein set out adopted by the governing body of said City and Transcript of Proceedings of said governing body at a regular meeting thereof held on the date therein set out, insofar as the same relates to the introduction, reading and adoption thereof as the same appears of record in my office.

I hereby certify that a true and complete copy of the Public Notice, attached hereto as Exhibit "A", was posted in prominent public view at the city Hall, 100 North Midwest Boulevard, Midwest City, Oklahoma, twenty-four (24) hours prior to the date of the meeting therein described, excluding Saturdays, Sundays and legal holidays. I further certify that a true, correct and complete copy of the schedule of regularly scheduled meetings of the City Council of the City for calendar year 2019 was filed in the office of the City Clerk of Midwest City, Oklahoma, as proscribed by law and in accordance with the Oklahoma Open Meeting Act.

WITNESS my hand and seal this 12th day of February, 2019.

City Clerk

(SEAL)



Memorandum

TO: Honorable Mayor and Council

FROM: Sara Hancock, City Clerk

DATE: February 12, 2019

SUBJECT: Consider and vote to approve a resolution relating to the incurring of indebtedness by the Trustees of the Midwest City Municipal Authority; waiving competitive bidding; approving a sales tax agreement; and containing other provisions relating thereto.

Action is necessary to start the transaction refunding the outstanding Series 2011 bonds issued in connection with the Reed Conference Center and Sheraton.

Staff recommends approval.

Sara Hancock
Sara Hancock, City Clerk

THE COUNCIL OF THE CITY OF MIDWEST CITY, OKLAHOMA, MET IN REGULAR SESSION IN THE COUNCIL CHAMBERS AT THE CITY HALL, 100 NORTH MIDWEST BOULEVARD, MIDWEST CITY, OKLAHOMA, ON THE 12TH DAY OF FEBRUARY, 2019, AT 6:00 O'CLOCK P.M.

PRESENT:

ABSENT:

Written notice of the schedule of regular meetings for the City Council for calendar year 2019 having been given to the City Clerk of Midwest City, Oklahoma prior to December 15, 2018, and the agenda for this meeting having been posted in prominent view at the City Hall, 100 North Midwest Boulevard, Midwest City, Oklahoma, twenty-four (24) hours prior to this meeting, excluding Saturdays, Sunday and legal holidays, all in compliance with the Oklahoma Open Meeting Act.

(OTHER PROCEEDINGS)

THEREUPON, Resolution No. 2019-____ was considered. Upon motion of _____, seconded by _____, the Resolution was passed and adopted with the following vote:

AYE:

NAY:

The Resolution was thereupon signed by the Mayor and attested and sealed with the seal of the City by the City Clerk and is as follows:

RESOLUTION

A RESOLUTION APPROVING THE INCURRING OF INDEBTEDNESS BY THE TRUSTEES OF THE MIDWEST CITY MUNICIPAL AUTHORITY; WAIVING COMPETITIVE BIDDING; APPROVING A SALES TAX AGREEMENT; AND CONTAINING OTHER PROVISIONS RELATING THERETO

WHEREAS, the Midwest City Municipal Authority (the "Authority") was created by a Trust Indenture, dated as of July 23, 1968 (the "Trust Indenture") for the use and benefit of the City of Midwest City, Oklahoma (the "City"), under authority of and pursuant to the provisions of Title 60, Oklahoma Statutes, Section 176 to 180.3, inclusive, as amended and supplemented, and other applicable statutes of the State of Oklahoma; and

WHEREAS, the Authority has heretofore issued its Midwest City Municipal Authority Capital Improvement Refunding Revenue Bonds, Series 2011, in the aggregate principal amount of \$26,630,000 (the "2011 Bonds"); and

WHEREAS, in order to refinance the 2011 Bonds and thereby achieve interest cost and other savings and to provide funds for the constructing, equipping, furnishing, and installing of capital improvements to the approximately 150 room hotel and related facilities adjacent to the Reed Center in the City of Midwest City, Oklahoma (the "Project") the Authority has determined to issue its Midwest City Municipal Authority Capital Improvement Refunding Revenue Bonds, Series 2019, in the aggregate principal amount of not to exceed \$35,000,000 (the "2019 Bonds"); and

WHEREAS, the Trustees of the Authority have received an offer from Wells Nelson and Associates, LLC (the "Underwriter") to purchase the 2019 Bonds under the terms and conditions set forth in the Bond Purchase Agreement (the "Purchase Agreement") between the Underwriter and the Authority a form of which has been presented to this meeting; and.

WHEREAS, there has been presented with this resolution a form of Sales Tax Agreement (the "Sales Tax Agreement") between the Authority and the City relating to the Bonds;

BE IT RESOLVED BY THE COUNCIL OF THE CITY OF MIDWEST CITY, OKLAHOMA:

Section 1. The incurring of indebtedness by the Trustees of the Midwest City Municipal Authority in the aggregate principal amount of not to exceed \$35,000,000 to be evidenced by the 2019 Bonds of the Authority is hereby approved by the Council of the City of Midwest City, Oklahoma, the governing body of the City.

Section 2. Competitive bidding is hereby specifically waived with respect to the issuance and sale of the 2019 Bonds and the issuance and sale of such 2019 Bonds to the Underwriter for a purchase price of not less than ninety-nine percent (99.0%) of the principal amount of the 2019 Bonds, all pursuant to the terms of the Purchase Agreement, which purchase price may constitute an underwriter's discount equal to not more than one percent (1.0%) of the principal amount of the 2019 Bonds is hereby specifically approved.

Section 3. The form of Sales Tax Agreement presented with this resolution be, and the same hereby is, approved, and the Mayor or Vice-Mayor of the City and City Clerk or any Deputy City Clerk of the City be, and they hereby are, authorized, directed and empowered to execute and deliver in the name and on behalf of the Authority the Sales Tax Agreement in said form and containing substantially the terms and provisions therein contained, with such additions or modifications as shall be approved by the officers executing the Sales Tax Agreement, the execution thereof by such officers being conclusive evidence of such approval.

Section 4. The Mayor or Vice-Mayor of Midwest City, Oklahoma, and City Clerk or any Deputy City Clerk of Midwest City, Oklahoma be, and they hereby are, authorized, directed and empowered to execute and deliver in the name and on behalf of the Authority all documents, closing papers, certificates and such other documents as are necessary to accomplish the issuance and delivery of the 2019 Bonds.

Section 5. The signatures of the officers of the City appearing on the Sales Tax Agreement and the agreements, documents, closing papers and certificates executed and delivered pursuant to this resolution shall be conclusive evidence of their approval of the changes, if any, in the form thereof and of their authority to execute and deliver such agreements and documents.

Section 6. The Mayor or Vice Mayor of the City of Midwest City, Oklahoma, and the City Clerk or any Deputy City Clerk of the City of Midwest City, Oklahoma be, and they hereby are, authorized and empowered for and on behalf of the City, to execute and deliver such further agreements and documents and to take such action as such officer or officers may deem necessary or desirable in order to carry out and perform the Sales Tax Agreement, as the same may be amended, and to effect the purposes hereof and to consummate the transactions contemplated by the Sales Tax Agreement and by the issuance and delivery of the 2019 Bonds.

ADOPTED this 12th day of February, 2019.

-
Mayor

ATTEST:

City Clerk

(SEAL)



Public Works Administration
Vaughn Sullivan, Director
vsullivan@midwestcityok.org
R. Paul Streets, Assistant Director
rstreets@midwestcityok.org
8730 S.E. 15th Street,
Midwest City, Oklahoma 73110
O: 405-739-1060 /Fax: 405-739-1090

Memorandum

TO: Honorable Mayor and Council

FROM: Vaughn K. Sullivan, Public Works Director

DATE: February 12, 2019

SUBJECT: Discussion and consideration of accepting the Oklahoma Spartans Youth Organization (OSYO) 2017-18 revised financial statement.

The Facility Lease Agreement with the Oklahoma Spartans Youth Organization (OSYO) requires the submission of an annual financial statement.

At the August 28, 2018 council meeting, City Council reviewed the OSYO financial statement. The original submission did not conform to the Finance Director's, and ultimately City Council's, recommendations. The Council instructed the OSYO President to work with the Finance Director in order to insure the necessary changes were made that meet the Finance Director's approval. The City Council instructed the OSYO President, and city staff, to resubmit the corrected financial statement by the end of 2018.

The 2017-18 revised OSYO financial statement is attached for your review.

Also attached is a time-line memorandum from the Parks & Recreation Manager. The memo details the Finance and Parks and Recreation Department's experiences with the OYSO President since OYSO was selected to organize and run little league football at Tel-Star North Football Complex.

Action is at the discretion of the Council.

Vaughn K. Sullivan
Public Works Director

Attachment: Football Financial Report
Attachment: Parks & Recreation Manager Memorandum

FINANCIAL REPORT

(Must cover 12 month period)

An Excel spreadsheet may be used with this information included

Organization Name: Oklahoma Spartans Youth Club

A. BEGINNING Balance as of	<u>1st Day of July 2017</u> Date	\$ <u>0.00</u> (A) Amount (must match beginning balance on first bank statement of reporting period)
B. Revenues:		
Fundraisers		\$ <u>0.00</u>
Donations		\$ <u>2000.00</u>
League Fees		\$ <u>4,050.00</u>
Tournament Fees		\$ <u>0.00</u>
Gate Fees		\$ <u>0.00</u>
Sponsors		\$ <u>3550.00</u>
Concessions		\$ <u>0.00</u>
Other _____ List		\$ <u>0.00</u>
Total Revenue:		\$ <u>9,600.00</u> (B)
C. Total AVAILABLE (A+B)		\$ <u>9,600.00</u> (C)
D. Expenses		
Coaches		\$ <u>0.00</u>
Referees		\$ <u>4800.00</u>
Tournament Expenses		\$ <u>0.00</u>
Supplies		\$ <u>0.00</u>
Utilities		\$ <u>0.00</u>
Bank Fees		\$ <u>0.00</u>
Concession (Cost of Goods Sold)		\$ <u>887.50</u>

Concession Equipment	\$ 0.00
Program Equipment	\$ 0.00
Dues & Subscriptions	\$ 0.00
Other <u>Field Service, spray Mower</u> List	\$ 4,800.00
Total Expenses:	\$ 9,600.00 (D)
REVENUE OVER/UNDER EXPENSES (B MINUS D)	\$ 0.00
ENDING Balance as of (C Minus D) <u>Last Day of June 2018</u> Date	\$ 0.00 Amount (must match ending balance on last bank statement of reporting period)

Information that must be attached to Financial Report:

1. Copies of bank statements.
2. Copies of general ledger (must be legible or will be returned).
3. List of organization's officers.

Items that must be available upon request:

1. Receipts/Invoices with check number or date of purchase (for electronic purchases) written in.
2. Copies of all organization IRS forms submitted.

Financial Position

(Must cover 12 month period)

An Excel spreadsheet may be used with this information included

Organization Name:

Oklahoma Spartans Youth Club

Assets:

Cash Balance

0.00

List all bank account balances for last day of reporting period.

Machinery & Equipment

0.00

For each item, list serial number, description, & purchase price.

List everything having a useful life of more than one year & over \$250 purchase price.

Total Assets:

0.00

(A)

Liabilities:

Loan Balances

0.00

List balance on last day of reporting period.

Credit Card Balances

0.00

List balance on last day of reporting period.

Accounts Payable

0.00

List balance for all accounts outstanding for more than 90 days (overdue) on last day of reporting period.

Total Liabilities:

0.00

(B)

Total Equity: **(A-B)**

0.00

FINANCIAL REPORT

(Must cover 12 month period)

An Excel spreadsheet may be used with this information included

Organization Name: _____

A. BEGINNING Balance as of	Date	\$ _____ (A)
		Amount (must match beginning balance on first bank statement of reporting period)
B. Revenues:		
Fundraisers		\$ _____
Donations		\$ _____
League Fees		\$ _____
Tournament Fees		\$ _____
Gate Fees		\$ _____
Sponsors		\$ _____
Concessions		\$ _____
Other _____		\$ _____
List		
Total Revenue:		\$ _____ (B)
C. Total AVAILABLE (A+B)		\$ _____ (C)
D. Expenses		
Coaches		\$ _____
Referees		\$ _____
Tournament Expenses		\$ _____
Supplies		\$ _____
Utilities		\$ _____
Bank Fees		\$ _____
Concession (Cost of Goods Sold)		\$ _____

Concession Equipment	\$ _____
Program Equipment	\$ _____
Dues & Subscriptions	\$ _____
Other _____ List	\$ _____
Total Expenses:	\$ _____ (D)
REVENUE OVER/UNDER EXPENSES (B MINUS D)	\$ _____
ENDING Balance as of (C Minus D) _____ Date	\$ _____ Amount (must match ending balance on last bank statement of reporting period)

Information that must be attached to Financial Report:

1. Copies of bank statements.
2. Copies of general ledger (must be legible or will be returned).
3. List of organization's officers.

Items that must be available upon request:

1. Receipts/Invoices with check number or date of purchase (for electronic purchases) written in.
2. Copies of all organization IRS forms submitted.

Financial Position

(Must cover 12 month period)

An Excel spreadsheet may be used with this information included

Organization Name: _____

Assets:

Cash Balance

List all bank account balances for last day of reporting period.

Machinery & Equipment

For each item, list serial number, description, & purchase price.

List everything having a useful life of more than one year & over \$250 purchase price.

Total Assets:

_____ (A)

Liabilities:

Loan Balances

List balance on last day of reporting period.

Credit Card Balances

List balance on last day of reporting period.

Accounts Payable

List balance for all accounts outstanding for more than 90 days (overdue) on last day of reporting period.

Total Liabilities:

_____ (B)

Total Equity: (A-B)



Public Works Administration
Vaughn Sullivan, Director
vsullivan@midwestcityok.org
R. Paul Streets, Assistant Director
rstreets@midwestcityok.org
8730 S.E. 15th Street,
Midwest City, Oklahoma 73110
O: 405-739-1060 /Fax: 405-739-1090

Memorandum

TO: Vaughn K. Sullivan, Public Works Director

FROM: Fran Gilles, Parks & Recreation Manager

DATE: January 23, 2019

SUBJECT: Oklahoma Spartans Youth Organization (OYSO) troubled history

General Background

- In 2015 OSYO was awarded the Facility Lease Agreement to run youth football at Tel-Star North for one year. On July 1, 2016 the Facility Lease Agreement was extended until June 30, 2021.
- First year went well; OSYO did everything expected of them. They had some league games and some big tournaments.
- In October 2016, the City got a phone call about teams not getting the number of league games they were supposed to get. That matter was eventually settled but those teams did not return to the league.

Restroom Trailer

- At the beginning of the lease the City allowed OSYO to use the City's new restroom trailer. Due to the blatant disregard for the care of the restroom, the City revoked this privilege.

Upkeep of the property

- On November 16, 2016, the City sent OSYO an email saying how the complex needed to be mowed.
- On May 24, 2017, the City sent OSYO an email saying the grass need to be mowed.
- On August 7, 2017, the City sent OSYO an email that there was a lot of trash and debris left over from a tournament.
- On August 22, 2017, the City sent OSYO an email saying the grass was too tall and that the City was putting them on notice that the complex needed to be kept in better shape.
- On September 18, 2017, Vaughn Sullivan and Fran Gilles had a meeting with OYSO President Dion Williams about taking care of the property. He was shown pictures of the height of the grass and that it needed to be mowed immediately. We also discussed fertilization of the complex as well.
- On September 21, 2017, the City sent OYSO an email asking when the complex was going to be mowed. The City also told Mr. Williams that the tall grass was a violation of the City Code's Ordinance on tall grass and weeds and that Code Enforcement may get involved and could issue a citation for the violation.
- On September 26, 2017, Code Enforcement gave a code violation for tall grass and weeds.

- On October 24, 2017, the City sent OSYO an email informing them about the trash and debris that left throughout the complex from the previous weekend's tournament. Once again the City reminded them that the complex and equipment were not being maintained to the City's standards that were originally agreed to by the OSYO.
- On December 4, 2017, Vaughn Sullivan, Christy Barron and Fran Gilles met with OYSO President Dion Williams about our expectations of how the complex should be kept and about OYSO's Financial Report.
- On July 31, 2018, we sent OYSO an email saying that the complex needed to be mowed and that Code Enforcement would once again issue a citation if not taken care of.
- On July 31, 2018, Code Enforcement issued OSYO another citation for tall grass and weeds.
- On August 3, 2018, the City sent OYSO another email about the condition of the fields at the complex for the weekend's upcoming tournament. The complex needed to be trimmed and there were piles of thatch stacked all around the complex. The City was concerned about the safety of the youth playing on the fields, in addition to the embarrassment to the City caused by the condition of the complex.
- On September 14, 2018, the City sent OYSO another email telling them how high the grass was at the complex and that it needed to be trimmed.
- On January 25, 2019, the City emailed OYSO telling them the lights on one of the fields were on. OYSO President Dion Williams emailed the City saying he would turn off the lights later that day around 5:00 PM. On Monday January 28, 2019, the City was notified by a citizen that the lights were still on at one of the fields. The City emailed OYSO President Dion Williams that the lights were still on. The City got no response back to its email of January 28, 2019. The Parks & Recreation Manager went out to Tel- Star and turned the lights off at _____.

Tournaments and League Games

- When OYSO first started in 2015 and 2016, OYSO had several tournaments in the fall season and several nights of league play.
- In the fall of 2017 there was very little league play and only a couple tournaments.
- In fall of 2018 there was no league play and only one tournament.

Financial Reports

- Part of the terms of the Facility Lease Agreement is that all youth sports organizations are to turn in a yearly financial statement to the City Council for their approval.
- For the fiscal year 2015/2016 OYSO turned in an acceptable statement for City Council's approval.
- For the fiscal year 2016/2017 the OYSO Financial Statement was not an acceptable report. The Council had some questions regarding the income on concession sales and gate collections.
- As a result of the unacceptable financial statements by OYSO, City Council required all youth sports organizations' yearly financial statements be approved by the City's Finance Director before being submitted to City Council for approval.
- At the August 28, 2018 City Council meeting the Finance Director could not approve OYSO's 2017/2018 financial statement because they had not provided her with the requirements she asked for. She has created templates for all of the organizations to use. (The template has been provided with this agenda item).

- City Council instructed OYSO President Dion Williams to work with the City's Finance Director in getting their finances in order. Council wanted the statements returned to them by the end of the year.
- On January 7, 2019 OYSO turned in their 2017/2018 yearly Financial Statements with zero's in each of the line items. OYSO President Dion Williams stated that after the August City Council meeting there would not be (a) a player's fee; (b) all employees were coaches and wives that volunteered; (c) all services for the fields would be donated out of his personal account; (d) the concessions stand would be run by volunteers and restocked by personal funds, and (e) any equipment that was needed or replaced was his personal property.

Finance Directors Communication with OYSO

- 12/4/17 - Met with Dion to discuss calendar year 2016 statements submitted to council for approval and supporting documentation that we would need to review. Noted that the bank statements submitted did not agree with the financial statements. Mr. Williams indicated that many items were being handled in cash and not run through bank account. I discussed with him that everything needs to be run through bank account so there is supporting documentation on amounts reported on the financial statements.
- 8/6/18 - Received CY 2017 financials reporting \$0 in activity for calendar 2017.
- 8/13/18 - Met with Dion to discuss calendar year 2017 financials that were submitted reporting \$0 activity. Went over what he needed to turn into us for council approval (i.e. bank statements, list of officers, etc.).
- 8/21/18 - Received documents requested. Discussed that conversation directing him to run everything through bank account did not occur until after calendar year 2017's football season was over. Therefore, the calendar year 2017 statements did not agree with bank statements either. Noted that football club bank statements were only provided through April, 2018. Discussed this with Dion and he indicated that he closed the account at the end of April, 2018. Asked him why he would close the bank account when he has been instructed to start running everything through his bank account. He indicated that no activity happens until fall. Dion further indicated he would be opening a new bank account for the football club at Mid First Bank at the end of August, 2018 to be used for the calendar year 2018 football season. We discussed that he needed to run everything through that bank account. Dion indicated that he would not be charging gate fees during 2018. There would be a registration fee to cover umpire fees. I told him that registration fees needed to be deposited in the club bank account with payments to umpires made from that account as well. I also told him that all money received from concession sales needs to be deposited timely into the bank account and when they purchase items to sell in the concession stand they should run that through the bank account as well.
- 8/28/18 - Calendar Year 2017 financial statements were placed on council agenda. Updated council on events.
- 9/11/18 - Requested 2018 football schedule from Dion with intent to stop by during a home game to observe that gate fees were not being charged as Dion had indicated to me and to observe whether they were running a concession stand.
- 9/25/18 - Did not receive response to request for schedule. Sent follow up email to Dion. Was directed to a website which contained the fall schedule. Noted that season ended in mid-October and there only appeared to be one home game left in October.

- 10/18/18 - Went to football field for last home game. No games were being played. Weather was cold and raining. Games had been canceled.
- 12/5/18 - Sent Dion email requesting that he send me the football club's bank statements from August to December so I could help him prepare calendar year 2018 statements. Received no response from him.
- 1/4/19 - Dion emailed list of club officers and calendar year 2018 statements again listing \$0 activity for year. No bank statements were included.
- 1/7/19 - Sent Dion an email asking for club bank statements and asking how there was \$0 activity. Asked him about registration fees and concessions and what was being done with that money. He responded that after the August council meeting the club decided to do away with registration fees and have teams pay umpires directly. He indicated all club employees were volunteers and all services at the field were donated out of his personal account. All tournaments at site were conducted by other organizations (teams) as fund-raisers. As for concessions, he said that if concessions were run, it was done by a team. He allowed food to be brought into the park from outside so they didn't always have a concession running. Dion indicated no bank account was opened because these changes resulted in the club not handling any money during the 2018 season.

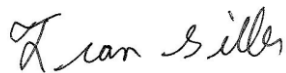

Fran Gilles
Parks & Recreation Manager



Human Resources
100 N. Midwest Boulevard
Midwest City, OK 73110
office 405.739.1235

Memorandum

DATE: February 12, 2019
TO: Honorable Mayor and Council
FROM: Catherine Wilson, HR Director

RE: Discussion and consideration of the approval of the Collective Bargaining Agreement between the City of Midwest City and the International Association of Firefighters Local (IAFF) #2066 as negotiated to be effective from July 1, 2018 to June 30, 2020.

Mayor and Council -

On February 7, 2018 the FOP Lodge 127 held a regular meeting and ratified a proposed multi-year Collective Bargaining Agreement to be effective from July 1, 2018 through June 30, 2020. This agreement was tentatively reached between the Lead Negotiator for the City Catherine Wilson, HR Director and IAFF Local 2066 President Howard Beabout on Tuesday January 29, 2019; changes in the proposed agreement are as follows:

- The Duration of the agreement will be from July 1, 2018 through June 30, 2020 as reflected in Article 3 of the CBA;
- Article 14 – Promotion and Review Board Procedure: Struck the Training major language, language added to the Fire Marshal rank requiring applicants must have held the position of Fire Prevention Officer for one year and/or have held the rank of Lieutenant or above for one year (has no monetary impact);
- Article 15 – Grievance Procedure: Language changes to each step of the grievance process to in cooperate the use of a Grievance Form which will assist us in administration of the grievance process. We also added language in section four that would allow for either party to request Mediation before going to arbitration (has no monetary impact);
- Article 17 – Injury Leave: added the following language: While on injury leave the members of the bargaining unit will continue to accrue leave; additionally, any extension of injury leave or leave accruals beyond six (6) months shall be subject to the City Manager’s approval (has no monetary impact);
- Article 22 – Longevity: Changed the year in which longevity will begin to the fifth (5th) year of employment and increased each year to \$125 paid on a bi-weekly basis. This increase has a monetary value for this CBA of \$27,832 or .35
- Article 24 – Wages: the IAFF membership will receive a 2.31% across the board increase to the base pay wage scale (Addendum A) to be effective July 1, 2018 through June 30, 2019 (monetary impact is approximately \$184,882); An additional step was added to the Firefighter pay scale for each of the following ranks Senior Firefighter (with an approx. monetary impact of \$37,618 or .48%), Assistant Fire Chief (with an approx. monetary impact of \$2,054 or .03%), Training Chief (with an approx. monetary impact of \$2,054 or .03%), Fire Marshal: there will not be a monetary



Human Resources
100 N. Midwest Boulevard
Midwest City, OK 73110
office 405.739.1235

impact for three years in this rank; for the second year of this agreement one of the three following must be met for an across the board base wage increase:

- For the second year of this agreement the total Fund 040 revenues minus other income (such as insurance recoveries, internal budget transfers, grant funds, etc.) must exceed original 2018-2019 Fund 040 budget by at least 3% on July 15, 2019; employees covered under the bargaining agreement shall receive a 2.25% across the board increase to the pay scale for FY 2019/2020 effective July 1, 2019 as reflected on Addendum A(3); or if
 - The original 2018-2019 Fund 040 budget is exceeded by 3.5% on July 15, 2019; employees covered under this agreement shall receive a 2.5% across the board increase to the pay scale for the FY 2019/2020 effective July 1, 2019 as reflected on Addendum A(4); or if
 - The original 2018-2019 Fund 040 budget is exceeded by 4.25% on July 15, 2019; employees covered under this agreement shall receive a 3.0% across the board increase to the pay scale for the FY 2019/2020 effective July 1, 2019 as reflected on Addendum A(5). (the example wage scales have been provided in the agenda back-up)
- Article 25 – Incentive Pay: Moved the Basic EMT incentive pay of \$57.69 per pay period or \$1,499.94 annually to the base pay of suppression operations and training chief (there was no monetary impact for this as it is a current incentive being paid to the membership); created two new incentives 1.) for EMT – Intermediate/Advance of \$10.00 per pay period and 2.) for EMT – Paramedics of \$20.00 per pay period (the approx.. monetary impact of this is \$3,640 or .04%). There was an increase for the Shift Commander (Ride-Out) of \$26.55 per pay period (the monetary impact is very small .009%)
 - Article 28 – Health Benefits: Cleaning up of the language.
 - Article 30 – Health Physical: removed age ranges to give one third of the department an opportunity annually to receive a physical (we already pay for these physicals).
 - Article 34 – Compensation at Separation: Addition of language for administration of the Beneficiary Designation as to Final Wages and Benefits form (there is no monetary impact for this change).
 - Article 38 – Pension Benefits: Changed the calculation language so that the City and the membership are paying pension benefits as outlined in Title 11 O.S. § 49-122. By shifting the extra 4% the City is paying on the employee’s behalf onto the base pay scale. Making the City’s contribution to the Oklahoma Firefighters Retirement System 14% and the employee’s share 9% for a total of 23% which is what the statute mandates.

Staff recommends approving the multi-year agreement effective July 1, 2018 through June 30, 2020 as negotiated.

Respectfully,

Catherine Wilson, MPA
HR Director



Collective Bargaining
Agreement for Fiscal
Year 20168/201720

~~***Both Parties Agreed to
Roll the CBA for FY
2017/18***~~

Between

The International
Association of Firefighters
Local #2066, AFL-CIO-CLC
and

The City of Midwest City

TABLE OF CONTENTS

<u>ARTICLE</u>	<u>DESCRIPTION</u>	<u>PAGE</u>
1	PURPOSE OF AGREEMENT	4
2	RECOGNITION	4
3	AUTHORITY AND TERM.....	4
4	MUTUAL RESPONSIBILITY TO AVOID DISCRIMINATION .	4
5	MANAGEMENT RIGHTS CLAUSE.....	5
6	PREVAILING RIGHTS	6
7	PROHIBITION OF STRIKES.....	7
8	UNION BUSINESS.....	7
9	SENIORITY	9
10	BULLETIN BOARD	10
11	SAFETY AND HEALTH.....	11
12	RESIDENCY REQUIREMENTS.....	12
13	OFF DUTY EMPLOYMENT	12
14	PROMOTION POLICY AND PROCEDURE.....	12
15	GRIEVANCE PROCEDURE	18
16	VACATION LEAVE	20
17	INJURY LEAVE.....	21
18	SICK LEAVE	21
19	EMERGENCY LEAVE.....	23
20	VEHICLE LIABILITY INSURANCE.....	24
21	HOLIDAY LEAVE	24
22	LONGEVITY	25
23	UNIFORM AND MAINTENANCE ALLOWANCE	26
24	WAGES.....	27
25	INCENTIVE PAY	27

26	MINOR MAINTENANCE	28
27	DUES AND SUBSCRIPTIONS.....	28
28	HEALTH BENEFITS.....	29
29	LIFE INSURANCE.....	30
30	HEALTH PHYSICAL	30
31	WORKING ON PERSONAL PROPERTY	31
32	HOURS OF WORK.....	31
33	OVERTIME AND CALLBACK	32
34	COMPENSATION AT SEPARATION	33
35	DRUG FREE WORKPLACE ACT	33
36	WAIVER.....	34
37	SUBSTANCE ABUSE POLICY	34
38	PENSION BENEFITS.....	34
39	SAVINGS CLAUSE	35
40	DISCIPLINARY ACTION	36

ARTICLE 1

PURPOSE OF AGREEMENT

It is the intent and purpose of this Agreement, entered into by and between the City of Midwest City, Oklahoma, a municipal corporation, hereinafter referred to as Employer, and International Association of Firefighters, AFL-CIO/CLC, Local 2066, hereinafter referred to as Union, to protect the public health, safety and welfare of the citizens of Midwest City, Oklahoma, from strikes, work stoppages or slow-downs by the Union. The purpose of this Agreement is to set forth terms and conditions of employment and to promote orderly, peaceful labor relations for the mutual interests of the City of Midwest City in its capacity as an employer and the firefighters as employees.

ARTICLE 2

RECOGNITION

SECTION 1. The City recognizes Local 2066 as the exclusive bargaining agent for all permanent paid firefighters of the Midwest City Fire Department, with the exception of the Fire Chief and one designated Administrative Assistant.

ARTICLE 3

AUTHORITY AND TERM

SECTION 1. Pursuant to Oklahoma state law, 11 O.S. § 51-101 et seq., the following Articles constitute an Agreement by and between the Employer and the Union.

SECTION 2. This Agreement shall be effective as of the, first day of July 2016~~8~~, and shall remain in full force and effect until the last day of June 2017~~20~~.

ARTICLE 4

MUTUAL RESPONSIBILITY TO AVOID DISCRIMINATION

SECTION 1. The Employer and the Union agree that there shall be no discrimination against any employee or applicant for employment because of race, creed, age, size, sex, religion or status of Union membership.

SECTION 2. The Union and all its members agree to comply with the objectives set forth in the Employer's Affirmative Action Program to ensure equal employment opportunity for all.

ARTICLE 5

MANAGEMENT RIGHTS CLAUSE

The Local recognizes the prerogative of the Employer to operate and manage its affairs in all respects and in accordance with its responsibilities, and the power or authority which the Employer has not officially abridged, delegated, granted or modified by this Agreement is retained by the Employer, and all rights, powers and authority the Employer had prior to the signing of this Agreement are retained by the Employer and remain exclusively without limitations within the rights of the Employer.

Except as may be limited herein, the Employer retains its rights in accordance with the laws of the State of Oklahoma and the responsibilities and duties contained in the Charter of the City of Midwest City and the ordinances and regulations promulgated thereunder. These rights include, but are not limited to:

- A. The determination of Fire Department policy, including the right to manage the affairs of the Fire Department in all respects;
- B. The right to assign working hours, including overtime;
- C. The right to establish modify or change work schedules, manning of shifts, assignments, etc;
- D. The right to direct the members of the Fire Department, including the right to hire, terminate, suspend, demote, promote, transfer or take any other disciplinary action against employees of the Fire Department for just cause;
- E. The determination of the table of organization of the Fire Department, including the right to organize and reorganize the Fire Department in any manner it chooses, including the size of the Fire Department, and the determination of job classification, ranks and positions based upon duties assigned;
- F. The determination of safety, health, and property protection measures for the Fire Department;
- G. The allocation and assignment of work to all members within the Fire Department;
- H. The sole judge of the qualifications of applicants and training of employees;

- I. The scheduling of operations and the determination of the number and duration of hours of assigned duty per working period;
- J. The establishment and enforcement of Fire Department rules, regulations and orders;
- K. The introduction of new, improved or different methods and techniques of operation of the Fire Department or changes in existing methods and techniques;
- L. The determination of the amount of supervision necessary;
- M. The control of the departmental budget;
- N. The right to take whatever actions may be necessary to carry out the mission of the City in situations of emergency;
- O. The right to relieve employees from duties because of lack of work, funds or other legitimate reasons;
- P. Organization of City governments;
- Q. Other matters as covered by the Merit System.

All rights and responsibilities of the Employer not specifically modified by this Agreement shall remain the functions of the Employer.

The above rights, responsibilities and prerogatives are inherent in the City Council and City Manager by virtue of statutory and Charter provisions and are not subject to delegation in whole or in part.

ARTICLE 6

PREVAILING RIGHTS

SECTION 1. All rules, regulations, rights, privileges, fiscal procedures, working conditions, departmental practices and manner of conducting the operation and administration of the Midwest City Fire Department currently enjoyed by the Union which are not included in this Agreement shall remain in full force unchanged and unaffected in any manner unless and except as modified or changed by the specific terms of this Agreement of either parties during the term of the contract by mutual consent.

ARTICLE 7

PROHIBITION OF STRIKES

SECTION 1. During the term of this Agreement, the Union agrees to a prohibition of strikes, work stoppage and slow-down.

SECTION 2. For the purpose of this Agreement, "strike" shall mean the concerted failure to report for duty, the willful absence from one's position, unauthorized holiday, sickness unsubstantiated by a physician's statement, the stoppage of work, or the abstinence in whole or in part from the full, faithful and proper performance of the duties of employment for the purpose of inducing, influencing or coercing a change of the conditions, compensation, rights, privileges or obligations of employment.

SECTION 3. Nothing contained in this Article shall be construed to limit, impair or affect the right of any employee to the expression of communication of a view, grievance, complaint or opinion on any matter related to the conditions or compensation of employment or their betterment, so long as the same does not interfere with the full, faithful and proper performance of the duties of employment.

SECTION 4. Upon notification confirmed in writing by Employer to Union that certain of its members are engaging in a wildcat strike, Union shall immediately, in writing, request such members to return to work at once and provide Employer with a copy of such request, and a responsible official of the Union shall publicly request them to return to work.

ARTICLE 8

UNION BUSINESS

SECTION 1. The Employer agrees that the Union shall have 240 hours leave available in order to conduct Union related business or activities; provided that the granting of such leave shall not impede the proper operation of the department as determined by the Fire Chief or his designee. The Union will be responsible for all other expenses incurred to attend the IAFF meeting. The Union president or secretary shall properly document all hours used and present a quarterly report to the Chief. Additional hours may be granted at the Fire Chief's discretion on a case by case basis.

SECTION 2. Members of the Union negotiating team, not to exceed five, shall be allowed time off without loss of pay for all negotiation meetings which shall be mutually set by the Employer and the Union.

SECTION 3. The president and secretary-treasurer of the Union shall be authorized time off with pay if and when the need arises to transact Union officially called meetings, not to exceed two per month, provided that the granting of such leave shall

not impede the operation of the Fire Department as determined by the Fire Chief or Shift Commander.

SECTION 4. The Union president or his designated representative may investigate grievances during working hours with the approval of the Fire Chief or Shift Commander.

SECTION 5. Upon written authorization from the employee, the Employer agrees to deduct regular monthly Union dues; PAC Fund contributions and Union sponsored insurance benefit programs from the earned wages of those permanent employees who are represented by the bargaining unit.

SECTION 6. The deduction shall be made in accordance with the City pay plan in an amount certified in writing to be correct by the treasurer of the Union. Changes in the amount of dues, PAC Fund contributions and Union sponsored insurance benefit programs will be certified in the same manner and shall be done at least thirty (30) days in advance of the effective date of such change.

SECTION 7. All eligible members of the bargaining unit desiring dues deduction, PAC Fund contribution deduction and Union sponsored insurance benefit programs shall individually sign an authorization form, provided by the Union. Authorization may be withdrawn by the employee by providing written notice to the Employer at least thirty (30) days prior to the effective date of withdrawal. Unless revoked by the employee the authorization shall remain in effect until the expiration date of the contract and will be automatically renewable with the adoption of each new contract.

SECTION 8. The Employer will deduct only Union dues, PAC Fund contributions, and Union sponsored insurance benefit programs from the employee's paycheck and will not deduct initiation fees, special assessments, fines or other Union fees. No deductions will be made when the salary to be paid an employee is not sufficient to cover the amount to be deducted. An illegal job action will result in the automatic termination of this privilege.

SECTION 9. The Employer will provide the Union treasurer with a monthly report showing the employee's name and the amount of deduction. All deductions refundable at the time of termination or resignation will be refunded by the Union.

SECTION 10. The total amount deducted shall be remitted to the treasurer of the Union minus fifteen dollars (\$15.00) per month which shall be the service fee paid to the Employer by the Union for this service. The service fee will include both Union deductions. A proper adjustment of same shall be made by the Union with the employee affected. A direct draft deposit will be made each pay day into designated bank accounts.

SECTION 11. The Union shall indemnify, defend and hold the Employer harmless against any and all claims, suits or other forms of liability that shall arise against the City on account of Union associated payroll deductions.

SECTION 12. Each Union member will be allowed two (2) payroll deductions, for Union purposes, at any time. The Union must notify the City of all members who will utilize the payroll deduction for PAC Fund contributions by June 1 of the previous contract year. The Union will provide signed consent forms for each member electing to participate in the PAC Fund and a list of all members including their requested deduction amount.

ARTICLE 9

SENIORITY

SECTION 1. Seniority shall mean the status attained by length of continuous service in the department. Seniority shall commence from the date that the employee is employed in the Midwest City Fire Department; however, until the initial employment probation is completed, employees shall not attain seniority status. At the conclusion of his initial employment probation, his initial probationary period shall count on his seniority to be accumulated in the future.

SECTION 2. Seniority shall be determined by the earliest date of continuous employment with the Midwest City Fire Department. If both employees began employment on the same date, then their seniority shall be determined by the date of their employment application with said City.

SECTION 3. Seniority will be the factor to be considered by the Fire Chief in determining the priority of each employee to the following:

- A. Time when vacation is granted.
- B. Time when compensatory time off is granted.
- C. Time when holidays are granted.

SECTION 4. Seniority will be a factor to be considered by the Employer in determining the priority of each employee to the following:

- A. Shift and duty assignments;
- B. Transfers.

SECTION 5. In the case of a personnel reduction of firefighters of Midwest City Fire Department, said actions shall be determined solely on seniority. No new employees

will be hired or new positions created until the laid-off employees have been given the opportunity to return to work.

SECTION 6: Laid off employees shall also be recalled based on seniority. Recall notification rights shall be for one year and shall be made in writing if recall is to occur. Written notice shall be sent to the employee's on file address by certified mail. An employee shall respond as to their desire for recall within two weeks from the mailing date or forfeit all recall rights.

ARTICLE 10

BULLETIN BOARD AND E-MAIL COMMUNICATIONS

SECTION 1. The Employer agrees to provide space for a reasonable number of bulletin boards for the posting of IAFF informational notices. Such notices shall contain no political advertisement, slanderous or inflammatory matter, as these terms are commonly defined in this community. The employer also agrees to provide the e-mail address local2066@midwestcityok.org to be used in the same regard as the bulletin boards.

Acceptable use of the bulletin board and e-mail would include:

- A. Recreational and social affairs of the IAFF;
- B. IAFF meetings;
- C. IAFF elections;
- D. Reports of IAFF committees;
- E. Rules or policies of the IAFF;
- F. Internal Fire Department E-mails (intra-departmental appropriate for distribution to employees).
- G. Other notices as approved for posting by the Human Resources Director.

SECTION 2. The Employer reserves the right to remove any material from such bulletin boards which, in its opinion, does not conform to the purpose of this Article.

SECTION 3. Only designated bulletin boards shall be used for posting any material on City property.

SECTION 4. The IAFF president shall be the responsible party for the e-mail address and for posting all information on the bulletin board and material to be posted should be dated and materials shall be removed in a timely manner by the IAFF president.

ARTICLE 11

SAFETY AND HEALTH

SECTION 1. The Union agrees to appoint one member from each shift and the Employer agrees to appoint one member from each shift to comprise the Joint Safety and Health Committee.(Committee for the purpose of this article). The Committee will have the responsibility of reviewing, investigating and reporting information on accidents and vehicle accidents in the Fire Department and recommending related or other safety and health needs to the Employer. The Fire Chief will appoint the Committee Chairman from within the Committee.

SECTION 2. All Fire Department related accidents and injuries (including vehicle accidents) will be reported to the Committee Chairman. The Chairman will call a meeting to be held monthly as needed, but at least quarterly, to investigate the accidents and injuries reported to the Chairman. The Committee will be provided with all information concerning the incident in question without breaching any confidentiality rights of the injured or involved.

SECTION 3. The Committee shall meet as deemed necessary by the Employer and the Union. After each meeting a written report shall be made and copies of the report submitted to the Fire Chief, the City's Safety Officer, the City Manager and the Union president.

SECTION 4. The majority of the Committee may cause an investigation of a reported health hazard or safety hazard. In the event that no majority decision could be reached by the Committee, then the Committee will select from the roster of the Fire Department personnel, excluding secretaries, the name of an individual to serve as a tie-breaker. The names on the roster will be placed in a container and the chairman of the committee shall draw a name from said container. The Committee will then present the issue to the person so selected for a majority decision.

SECTION 5. Committee members shall also be granted time off without loss of pay to conduct investigations of safety and health problems if deemed necessary by the Employer. Time off shall be approved by the Shift Commander provided that the granting of such leave shall not impede the operation of the Fire Department.

SECTION 6. Investigations and/or recommendations by the Committee are for the mutual objectives of the parties in protecting the safety and health of the employee(s), equipment, property, and the general public. It is understood that the Committee has no responsibility to recommend or implement any action against employees as a result of these investigations or reporting responsibilities. Such action shall remain the solely the responsibility of City management. The City Manager shall acknowledge receipt of the report from the Joint Safety and Health Committee within thirty (30) days and inform the Committee of any administrative action taken.

ARTICLE 12

RESIDENCY REQUIREMENTS

SECTION 1. The Employer agrees that the City of Midwest City, a municipal corporation, has a population, according to the latest federal census, in excess of fifty thousand (50,000) people.

SECTION 2. The Employer agrees to comply with 11 O.S. § 22-127 that the municipal governing body by ordinance may designate which appointed officers and employees shall reside within the municipality; but police officers, firefighters and other municipal employees need not be actual residents of the municipality where they are employed in municipalities of five thousand (5,000) population or more, according to the latest federal census.

ARTICLE 13

OFF- DUTY EMPLOYMENT and Emergency Contact

SECTION 1. Employees may engage in additional employment outside the official hours of duty. For staffing purposes during large scale emergencies, personnel are required to maintain a current number with the Fire Chief's Office at which said person can be personally contacted.

ARTICLE 14

PROMOTION POLICY AND REVIEW BOARD PROCEDURE

SECTION 1. All employees shall be entitled, after meeting certain requirements, to a fair and equitable opportunity for advancement as established herein. The goal of this procedure is to select the most qualified individual(s), for the available position(s), in an organized and orderly manner.

SECTION 2. The administration of this procedural guide will be coordinated by a promotion committee of three (3) members. The promotion committee will coordinate examination procedures and assure proper administrative controls. The promotion committee will consist of one (1) member appointed by the Union, the Human Resources Director or designee and the Fire Chief or designee. The Union appointee shall be of equal or above rank to the position being tested for, and will review the assessment center dimensions and weighting factors prior to the conducting of an assessment center. In the event that a committee member becomes temporarily or permanently unavailable, he/she will be replaced by a substitute member. The substitute member will be selected in the same manner as the member they are replacing.

SECTION 3. Fire service personnel from Midwest City Fire Department will develop and score the written and assessment centers. The Training Section, or an appropriate

designee from either inside or outside the department will be responsible for developing the written test and assessment center(s) as determined by the Fire Chief. The ~~Training Section~~ Training Section will also be responsible for administering the assessment center(s). The Promotions Committee will meet in the last quarter of the fiscal year to determine and publish the bibliography for all testing to be conducted in the next fiscal year. The bibliography will go into effect on July 1 and remain in effect during the next contract year.

SECTION 4. Examinations for all positions will be given as a position becomes vacant when possible. Notification of said examination to eligible employees will be conducted as follows:

1. A hard copy of the notification will be delivered to each fire station by ~~the Training~~ the Training Section. The notification will include an eligibility list of all personnel who are qualified by this contract to participate in the promotion process.
2. The on duty Company Officer of each station will sign a form signifying that the notification was delivered. The on duty CO will then post the notification on the bulletin board in the appropriate place.
3. The sign up list will be kept at Head Quarters Fire Station and the sign up period will be 14 days not including weekends and holidays.
4. After 14 days, the Promotion Committee will meet to discuss any variances they deem necessary to continue the process unless otherwise specified within this agreement.

All applicants for promotions in each position that qualify as outlined by position and signed-up as required will be tested and placed on the promotion sequence list, beginning with the highest total score to the lowest total qualifying score. The ~~Shift Commander, Training Chief, Training Major, Fire Marshal, and Fire Prevention Officer~~ promotion list will be in force for the contract term (reference Article 3 Section 2). The Apparatus Operator promotion list will be in force for the contract term or until the three (3) highest scored eligible applicants (including ties) have been promoted, whichever is the longer time period. The Company Officer promotion list will be in force for the contract term or until the two highest scored eligible applicants (including ties) have been promoted, whichever is the longer time period. Department promotions will be made from the eligibility list in order of highest to lowest total scores by the Fire Chief. At no time will a member be allowed to skip a rank except where provided.

SECTION 5. Candidates that are on disciplinary suspension or probation at the time of examination will not be eligible for testing. Members who made the promotion list are not eligible for promotion if they are put on probation or suspension. If a candidate who was in the top three for Apparatus Operator or top two for Company Officer becomes ineligible for reasons previously addressed and three AO's or two CO's are promoted while he is ineligible, he will NOT be guaranteed a promotion when he returns to the list as stated in previous sections. After the designated period of disciplinary probation or suspension, the member will return to the promotion list in the same order he was listed.

SECTION 6. The examination will be comprised of two (2) distinct elements as further described. The final grade of the examination will be the total points scored on all elements plus one (1) point to be added to the final score for every year of continuous service on the Midwest City Fire Department for a maximum of 20 points. (All current employees will be considered continuous service. The continuous service requirement in this Article shall become effective July 1, 2002).

A. Written Test

1. The written test will consist of one hundred (100) points. Passing shall be considered seventy (70%) percent.
2. Only clear, direct questions requiring concise answers will be used. Neither trick questions nor ambiguous questions will be part of the written test.

B. Assessment Center

1. The Assessment Center will consist of elements that will total one hundred (100%) percent equal to written test.
2. The Fire Chief shall assemble a list of eligible assessors from within the Midwest City Fire Department. The list shall consist of those members of the Midwest City Fire Department of equal rank or above and have held the position for at least one year for the position being tested for. The list shall then be submitted to the Human Resources Director who will select from the list three (3) individuals and one (1) alternate to act as the assessor for the Practical Assessment Center. The assessment center(s) will then be scored by the three (3) the assessors will submit a score for each candidate during each assessment using an assessment form agreed upon by the promotion committee. At the conclusion of the assessment center, the assessors will submit their final scores in a Final Dimension Summary form agreed upon by the promotion committee, which shall be tabulated as follows:
 - a. The assessors' scores shall be within one (1) point of each other before any final scores are tabulated in the final dimension summary.
 - i. Example of the scoring: acceptable (1-2-2),(6-6-7), unacceptable (3-4-5), (5-5-7)
 - b. Assessor's scores are then averaged and calculated into a percentage and totaled.

SECTION 7. Employee receiving the highest score from totals of the written examination, assessment center(s), years of service, and review board (if applicable) will be totaled and the employee's name will be placed on the eligibility list. In the event of a tie, the person with the most seniority will be advanced first.

SECTION 8. Applicants will be given a control identification number at the beginning of the written examination. Applicants will be told to write this number down for use during the selection period.

All applicants may review the correct answers to the written test from the conclusion of the testing process for one and one half days following the examination. Any protest of the written test must be filed during this period with the Human Resources office. After the posting of the test results, all applicants will be allowed to review their written and/or practical factor examination where appropriate.

SECTION 9. Eligibility - Firefighter (Corporal)

Applicants shall be required to have been employed with this Department for a minimum of three (3) continuous years performing the duties as firefighter. Applicants must be certified relief drivers by the Midwest City Fire Department training standards.

SECTION 10. Eligibility - Sergeant (Apparatus Operator)

Applicants shall be required to have held the position of Corporal with this Department for a minimum of two (2) years performing the duties as Corporal. Applicants must be certified Relief Drivers by the Midwest City Fire Department training standards. Any applicant attaining the position of Sergeant (Apparatus Operator) must successfully complete the "Blue Card" Incident Command Certification Program within one year of attaining this position.

SECTION 11. Eligibility – Lieutenant (Apparatus Operator)

Applicants shall be required to have been employed with this Department for a minimum of seven (7) continuous years. Applicants must have held the position of Sergeant for a minimum of two (2) years. Applicant must successfully complete Fire Officer I and a IFSAC Instructor I approved by the Fire Chief. Applicants must also attend a 1 week Midwest City Fire Dept. Lieutenants Academy (to be held once annually as needed) prior to entry into this rank.

SECTION 12. Eligibility – Captain (Company Officer) Applicants shall be required to have been employed with this Department for a minimum of seven (7) continuous years. Applicants must have held the position of Sergeant for a minimum of two (2) years. Applicants must be certified as an IFSAC or PRO-Board Instructor I.

SECTION 13. Eligibility – Major (Company Officer)

Applicants shall be required to have been employed with this Department for a minimum of nine (9) continuous years. Applicants must have held the position of Captain for a minimum of two (2) years. Applicants must successfully complete Fire Officer II and Fire Causes Determination class approved by the Fire Chief. Applicants

must also attend a one week Midwest City Fire Dept. Majors Academy (to be held once annually as needed) prior to entry into this rank. Only Training and Ride-Out Majors will be allowed into Step 5 of the Major pay scale.

~~**SECTION 14.** Eligibility - Training Major~~

~~Applicants shall be required to have been employed with this department for a minimum of nine (9) continuous years. Applicants must have held the position of Captain for a minimum of two (2) years. Applicants must be certified as an IFSAC or PRO-Board Instructor II.~~

SECTION 154. Eligibility - Shift Commander

Applicants shall be required to have been employed with this Department for a minimum of nine (9) continuous years. Applicants must have held the position of Captain for a minimum of two (2) years.

SECTION 165. Eligibility - Training Chief

Applicants shall be required to have been employed with this Department for a minimum of nine (9) continuous years. Applicants must have held the position of Captain for a minimum of two (2) years. Applicants must be certified as an IFSAC or PRO-Board instructor II. Any applicant attaining the position of Training Chief must successfully complete the "Blue Card" Incident Command Certification Instructor Program within one year of attaining this position.

SECTION 176. Eligibility - Fire Prevention Officer

Applicants shall be required to have been employed with this Department for a minimum of three (3) continuous years.

- A. Any applicant attaining the position of Fire Prevention Officer must successfully complete a fire inspection and investigation training within one year of attaining this position as approved by the Fire Chief.

SECTION 187. Eligibility - Fire Marshal

Applicants shall be required to have been employed with this Department for a minimum of seven (7) years. Applicants must have held the position of Fire Prevention Officer for a minimum of one (1) year and/or have held the rank of Lieutenant or above for one (1). Any applicant attaining the position of Fire Marshal must successfully complete fire inspection and investigation training within one (1) year of attaining this position as approved by the Fire Chief.

SECTION 198. If fewer than two (2) applicants apply for any position where eligibility is set forth in this Agreement, the promotion committee will make variances as necessary. If a variance for time in rank is made, the successful applicant must maintain the promoted rank for four (4) years before being eligible for promotion to the next higher rank.

SECTION 2019. Promotion Following Reduction in Rank

- A. Any person voluntarily taking a reduction in rank shall be eligible, without penalty, to test for that next rank for which he was eligible before reduction.
- B. Any person who is involuntarily reduced in rank shall be eligible after six (6) months to test for the next rank above the one to which he was demoted.

SECTION 210. Rank and Classification

When an employee is promoted to a higher rank, excluding those employees being reclassified from Firefighter to Senior Firefighter, he shall be advanced to Step "1" of the new rank. Promoted employees will assume a new anniversary date commensurate with the promotion. Firefighters who are reclassified to Senior Firefighter will be placed in Step "1" of the new rank and will retain their anniversary date.

SECTION 221. Promotion Review Board

- A. The Review Board applies only to promotions for the ranks of Shift Commander, Training Chief, Training Major, Fire Marshall and Fire Prevention Officer.
- B. After passing the written test, each candidate will appear before a promotion review board consisting of three (3) Assistant Chiefs (at least two being Shift Commanders) and the Fire Chief. The candidate will be evaluated for one and/or all the following factors: work habits, performance under stress, initiative, motivation, and leadership, ability to delegate to fellow workers, appearance and review of the personnel file.
- C. The review board will assess 0 - 20 points for these factors as follows:
 - 1. Fire Chief will award 0-10 points.
 - 2. Assistant Chiefs will award an averaged total of 0-10 points individual scores must be within a range of one (1) point from each other's score.

ARTICLE 15

GRIEVANCE PROCEDURE

SECTION 1. A grievance shall be defined as any dispute regarding the meaning, interpretation, application or alleged violation of the terms and provisions of this Agreement. The Union or any employee or employees covered by this Agreement may initiate a grievance within ten (10) calendar days of the act or actions giving rise to the grievance, or within ten (10) calendar days from the date knowledge is gained of such act or actions, in accordance with the following procedure.

SECTION 2. The Union president or his designee may report an impending grievance to the Fire Chief in order to forestall its occurrence.

SECTION 3.

Step 1: Any employee with a grievance shall utilize the grievance form (located in the back of the CBA or on the Fire Dept. X Drive) to submit his/her grievance to their AC ~~first discuss his grievance with his immediate supervisor.~~ The Local president or designee may be present at said discussion if the employee so requests. The ~~immediate supervisor~~ AC shall give his/her response to the employee within six (6) calendar days. ~~†~~The Fire Chief will be notified of all grievances and potential grievances within twenty four (24) hours and will be forwarded a copy of the original grievance form along with the AC's written response to the employee.

Step 2 If the grievance is not resolved in Step 1 above, the employee shall have the right to submit his/her grievance in writing utilizing a copy of the original grievance form that they submitted to their AC within six (6) calendar days citing the article of the contract violated, and the remedy requested to the Fire Chief. The Fire Chief shall submit his answer in writing within six (6) calendar days.

Step 3 If the grievance is not resolved in Step 2, the grievance shall be submitted in writing and will include a copy of the original grievance form with any additional information within six (6) calendar days to the Labor Relations Officer. The Labor Relations Officer shall meet with the Fire Chief, the aggrieved employee and a grievance committee of the Union within ten (10) calendar days from receipt of the grievance. The Labor Relations Officer will submit a written response which will include a copy of the original grievance form and any additional information to the employee and the Union within six (6) calendar days of the meeting.

Step 4 If the grievance is unresolved after receipt of the answer from the Labor Relations Officer, the grievance may be submitted in writing and will include a copy of the original grievance form and all additional information

gathered through the process to the City Manager within six (6) calendar days. The City Manager shall review the grievance and give his/her written response which will include a copy of the original grievance form and all additional information within six (6) calendar days.

SECTION 4. If the grievance is unresolved after receipt of the answer from the City Manager, either party by mutual agreement may request impartial Mediation to resolve the matter. A request for Mediation will be made with the Federal Mediation and Conciliation Service within ten (10) calendar days of the City Manager's decision. ~~the Union may request that the matter be submitted to impartial arbitration. If the matter is not resolved through Mediation the Union may request that the matter be submitted to impartial arbitration.~~

SECTION 5. ~~Theis~~ request for impartial arbitration shall be made in writing and be submitted to the City Manager within ten (10) calendar days from receipt of the City Manager's and/or the Mediator's grievance answer. Within ten (10) calendar days from receipt of the request for arbitration, the parties shall jointly request a panel of seven (7) arbitrators from the Federal Mediation and Conciliation Service.

- A. Within five (5) calendar days from receipt of such panel, a representative of the Union and the City shall meet or discuss and alternately strike names until one (1) arbitrator remains who shall be selected as the impartial arbitrator. The party requesting arbitration shall strike the first name.
- B. The date of the Arbitration Hearing shall be set (for some future hearing date) within ten (10) calendar days from the date the arbitrator is notified of his selection.
- C. Within ten (10) days after the conclusion of the hearing which shall begin after completion of the briefing period, if any, of twenty (20) days, the arbitrator shall issue a written opinion containing findings and recommendations with respect to the issues presented. A copy of the opinion shall be mailed or delivered to the Union and the Employer.
- D. The arbitrator's authority shall be limited to the interpretation and application of the terms of the Agreement and/or any supplement thereto. The arbitrator shall have no jurisdiction to establish provisions of a new agreement or variation of the present Agreement or to arbitrate away, in whole or part, any provision of this Agreement or any supplements thereto or amendments thereof, nor shall any wage structures or structures of job classification be subject to arbitration. This shall not preclude individual wage grievances. The arbitrator shall only consider and make a decision with respect to the specific issues submitted to

him/her by the parties and shall have no authority to make a decision on any issue not so submitted.

- E. With respect to the interpretation, enforcement or application of the provisions of this Agreement, which do not relate to the statutory and Charter authority of the Employer, the decision, findings and recommendations of the arbitrator shall be final and binding on the parties to this Agreement to the extent the arbitrator's decision is in accordance with the provisions of this section.
- F. The cost of the impartial arbitrator shall be shared equally between the Union and the Employer. If a transcript of the proceedings is requested, then the party so requesting shall pay for it unless the parties mutually agree they each want a copy and will therefore share in the costs equally.

SECTION 6. All time limits set forth in this Article may be extended by mutual consent but, if not so extended, they must be strictly observed. If a party fails to pursue any grievance within the time limits provided, he shall have no further right to continue the grievance.

SECTION 7. It is specifically and expressly understood that filing a grievance under this Article, which has as its last step final and binding arbitration, constitutes an election of remedies and a waiver of any and all rights by both parties, the Union or other representatives of the party to litigate or otherwise contest the last answer rendered through the Grievance procedure in any court or other appeal forum.

(LEFT BLANK INTENTIONALLY)

ARTICLE 16

VACATION LEAVE

SECTION 1. All employees covered by this Agreement shall be entitled to vacation leave at the following rates:

A. Employees working eight (8) hour shifts:

<u>Length of Service</u>	<u>Leave Accrual Rates</u>
12-59 Months	4.2 hrs per pay period
60-119 Months	5.1 hrs per pay period
120-179 Months	6.0 hrs per pay period
180-239 Months	7.0 hrs per pay period
240 Months or More	7.85 hrs per pay period

B. Employees working twenty-four (24) hour shifts:

<u>Length of Service</u>	<u>Leave Accrual Rates</u>
12-59 Months	6.05 hrs per pay period
60-119 Months	7.43 hrs per pay period
120-179 Months	8.82 hrs per pay period
180-239 Months	10.20 hrs per pay period
240 Months or more	11.59 hrs per pay period

SECTION 2. Vacation time taken off normal work will be charged at the rate of twenty-four (24) hours for each shift off for twenty-four (24) hour workers and eight (8) hours off for eight (8) hour workers. No more than one hundred forty-four (144) hours of vacation may be taken in succession by firefighters working twenty-four (24) hour shifts, and no more than ninety-six (96) hours in succession may be taken by eight (8) hour workers.

SECTION 3. When a holiday occurs during the vacation period, an additional day off will be allowed. However, additional days off will not be allowed for any other reason. Vacation leave should be taken during the year when it is earned but it can be accumulated from one year to the next, not to exceed three hundred (300) working hours for twenty-four (24) hour workers and not to exceed two hundred sixteen (216) hours for eight (8) hour workers. At the end of the contract year, a maximum of twenty-four (24) hours of accumulated leave in excess of three hundred (300) hours for 24 hour workers and a maximum of twenty-four (24) hours of accumulated leave in excess of two hundred sixteen (216) hours for eight hour workers shall be paid at the straight rate of hourly pay through June, 2008.

SECTION 4. If an employee has unused vacation time and separates from the municipal service, he shall be paid for his accumulated vacation leave.

ARTICLE 17

INJURY LEAVE

SECTION 1. Any employee who is injured on the job shall be eligible for injury leave with pay to the extent of six (6) calendar months for each new separate injury, and such leave is not charged against the employee's ~~sick leave or vacation leave~~ accrued leave; While on injury leave the members of the bargaining unit will continue to accrue leave; additionally, any extension of injury leave or leave accruals beyond six (6) months shall be subject to the City Manager's approval.

SECTION 2. The employee's eligibility for injury leave with pay shall be dependent on compliance with Title 11 and Title 85 of the Oklahoma Statutes, Oklahoma Firefighters Pension and Retirement System, additions and amendments.

SECTION 3. Employees on injury leave shall be in compliance with provisions or restrictions of their doctor or physician in all aspects of their outside employment or personal activities.

Any violation of this section shall be dealt with according to the terms of Title 85, Oklahoma Statutes, and Title 11, Oklahoma Firefighters Pension and Retirement System, additions and amendments.

ARTICLE 18

SICK LEAVE

SECTION 1. Sick leave is accrued from the day of original appointment. Sick leave shall be granted for the following reasons:

- A. Personal illness or physical incapacity, resulting from causes beyond the employee's control.
- B. Medical, dental or optical appointments not to exceed four (4) hours each.
- C. Sickness or medical treatment of a member of the employee's household that requires the employee's personal care or attention.

SECTION 2. Employees working 24-hour shifts shall accrue sick leave at the rate of 5.54 hours per pay period. Employees working 24-hour shifts may accumulate up to a maximum of one thousand, three hundred and fourteen (1,314) hours and shall be paid for accumulated hours over 1,314.

SECTION 3. Employees working 8-hour shifts shall accrue sick leave at the rate of 3.70 hours per pay period. Employees working eight (8) hour shifts may accumulate up to a

maximum of nine hundred, thirty-nine (939) hours and shall be paid for accumulated hours over 939.

SECTION 4. Employees who have accumulated hours over the maximum shall be paid at the rate of 1/2 days pay for each day accumulated over the maximum and shall be paid bi-weekly.

SECTION 5. Statement of Attending Physician. Sick leave with pay in excess of three (3) consecutive work days shall be granted only after presentation of a written statement by a licensed physician certifying that the employee's condition prevented him from performing the duties of his position. In cases where abuse of sick leave is suspected a statement for sickness from a health care provider may be required after one (1) shift at the discretion of the Fire Chief. When a statement of sickness is required the employee shall be notified the day of the occurrence.

SECTION 6. Upon termination of employment

- A. Upon termination of employment with less than ten (10) years of continuous employment, no payment shall be made to the terminating employee for unused sick leave.
- B. Upon termination from employment after ten (10) years of continuous employment for any reason, the terminating employee shall receive payment for accrued sick leave. The employee's sick leave bank balance shall be paid to the employee at fifty percent (50%) of the employee's regular hourly rate of pay.
- C. If an employee dies in the line of duty, the deceased employee's sick leave bank balance shall be paid to the deceased employee's named beneficiary at the deceased employee's regular hourly rate. A death in the line of duty shall be defined as follows:
 - i. A death in the line of duty occurs when suffered in the performance or discharge of a duty required of the employee as an active member of the City of Midwest City Fire Department.

SECTION 7. Employees who separate from the City with an on-the-job injury or after twenty (20) years of continuous service shall be paid for accumulated hours up to the maximum at the rate of one-half (1/2) days' pay for each shift.

SECTION 8. Sick Leave Saving Incentive: Employees who use two (2) shifts or fewer per contract year shall receive incentive pay in the following manner:

0 shifts sick leave used	\$900.00
1 shift sick leave used	\$500.00
2 shifts sick leave used	\$300.00

- a) Pay for sick leave incentive will be figured at the end of the contract year and shall be paid on the second payday in July.
- b) Employee shall receive pro-rated payment for portions of full shifts not utilized.

SECTION 9: Employees transferring from twenty four (24) hour shift to an eight (8) hour shift shall be paid for any accrued sick leave over the maximum allowed accrual of an eight (8) hour shift employee at the rate of one half (1/2) days' pay for each twenty four (24) hours.

ARTICLE 19

EMERGENCY LEAVE

SECTION 1. Emergency leave with pay shall be granted for the following reasons. A serious sickness, reviewed on a case-by-case basis by the Fire Chief; an unscheduled hospitalization of a member of the employee's or their spouse's immediate family that requires an employee's personal care or attention; an emergency relating to a member of the employee's or their spouse's immediate family which requires immediate action; or the death of a member of the employee's or the employee's spouse's immediate family (parents, grandparents, brothers, sisters, sons, daughters, spouse, father-in-law, mother-in-law, son-in-law, daughter-in-law, dependent members of the employee's household and, in the case where the employee was raised by persons other than natural parents, those persons who acted in the capacity of natural parents).

SECTION 2. In the event an employee is notified of the impending death of those listed as immediate family, emergency leave shall be granted, subject to the limitations noted herein.

SECTION 3. Maximum number of days at a time allowed for 24 hour shift workers is two (2) shifts and the maximum number of working days allowed per calendar year is four (4). The maximum number of working days at a time allowed for 8 hour shift workers is three (3) and the maximum number of working days allowed per calendar year is seven (7).

SECTION 4. Additional emergency leave may be granted at the department head's discretion.

SECTION 5. When there is a death in the family of the employee of a person other than those stipulated as immediate family in Section One (1) above, an employee may be granted one shift of emergency leave with pay.

ARTICLE 20

VEHICLE LIABILITY INSURANCE

The Employer shall provide liability insurance protection for every employee responsible for the operation of fire apparatus and/or any other city owned vehicle. The cost of such protection will be paid for by the Employer, subject to limits established by the Employer and subject to the legality of Employer paying same, provided such employee can be insured, and at the same rate as other City employees.

ARTICLE 21

HOLIDAY LEAVE

SECTION 1. 24-Hour Shift Employees:

- A. All 24-hour shift employees covered by this Agreement are entitled to a total of 240 hours of Holiday Leave per year.
- B. If an employee separates from City employment during the term of the contract, Holiday Leave shall be computed as accruing 9.23 hours in each of 26 pay periods throughout the year.
- C. Twenty four (24) hour shift employees completing their probationary year shall have their Holiday Leave computed as accruing 9.23 hours in each of the twenty six (26) pay periods remaining in the fiscal year.
- D. Employees may take Holiday Leave in 12 or 24-hour increments and/or up to forty eight (48) hours in one (1) hour increments.

All 24-hour shift employees are required to use a minimum of 144 hours of Holiday Leave each year. Holiday Leave hours not used by the employee will be paid to each employee at the rate of straight time. Employee's may elect to be paid for up to forty eight (48) hours in the first paycheck of December and/or up to 96 hours in the second pay check in June.

E The City and the Union agree that the work schedule on Veteran's Day and September 11th in remembrance of Patriot Day will be the same as a weekend work schedule. The morning work schedule will be utilized for applicable safety-training.

SECTION 2. 8-Hour Shift Employees:

- A. All 8-hour shift employees covered by this Agreement are entitled to eighty (80) hours of Holiday Leave per year. The authorized Holiday Leave days are as follows:

New Years' Day	Thanksgiving Day
Memorial Day	The day after Thanksgiving
Independence Day	Christmas Eve
Labor Day	Christmas Day

Two additional days of each employee's choosing

If an authorized Holiday Leave falls on an employee's regularly

scheduled day off, the employee must select another day during that year as a substitute for the authorized Holiday Leave Day. If an authorized Holiday Leave falls on a Saturday or Sunday, the preceding Friday or the following Monday, respectively, shall be the authorized Personal Time off.

- B. If an employee separates from City employment during the term of the contract, Holiday Leave shall be computed as accruing 3.08 hours in each of 26 pay periods throughout the year.
- C. Employees working eight (8) hour shifts and completing their probationary year shall have their Holiday Leave computed as accruing 3.08 hours in each of the twenty six (26) pay periods remaining in the fiscal year.
 - D. Employees may take Holiday Leave in 4 or 8 hour increments and/or the employee may take up to eight (8) hours in one (1) hour increments .
 - E. All 8-hour shift employees are required to use a minimum of 64 hours (those named in Section A or an approved alternate) of Holiday Leave each year. Holiday Leave hours not used by the employee will be paid to each employee at the rate of straight time. Employees may elect to be paid for up to eight (8) hours in the first paycheck in December and/or up to sixteen (16) hours in the second paycheck in June.

(LEFT BLANK INTENTIONALLY)

ARTICLE 22

LONGEVITY

Longevity pay is made in recognition of an employee's tenure and faithful service to the City. Longevity pay is computed as follows:

- A. ~~Employees hired before June 30, 1983 shall receive \$12.64 per month for each completed year of continuous service to a maximum of 25 years (The longevity schedule for these employees is the 2002-2003 titled schedule located prior to Addendum A, Pay Scale);~~
- BA. Employees hired after June 30, 1983 shall be eligible to receive the following longevity benefits at the beginning of the 6th 5TH year (61st 49TH month) of service based ion the employee's hire date:

	<u>Years of Service</u>		<u>Annual Longevity Pay</u>		<u>Per Payday Longevity Pay</u>
\$125.00	5	-	\$625.00	-	\$24.04
\$125.00	6	-	\$750.00	-	\$28.85
\$125.00	7	-	\$875.00	-	\$33.65
\$125.00	8	-	\$1,000.00	-	\$38.46
\$125.00	9	-	\$1,125.00	-	\$43.27
\$125.00	10	-	\$1,250.00	-	\$48.08
\$125.00	11	-	\$1,375.00	-	\$52.88
\$125.00	12	-	\$1,500.00	-	\$57.69
\$125.00	13	-	\$1,625.00	-	\$62.50
\$125.00	14	-	\$1,750.00	-	\$67.31
\$125.00	15	-	\$1,875.00	-	\$72.12
\$125.00	16	-	\$2,000.00	-	\$76.92
\$125.00	17	-	\$2,125.00	-	\$81.73
\$125.00	18	-	\$2,250.00	-	\$86.54
\$125.00	19	-	\$2,375.00	-	\$91.35
\$125.00	20	-	\$2,500.00	-	\$96.15
\$125.00	21	-	\$2,625.00	-	\$100.96
\$125.00	22	-	\$2,750.00	-	\$105.77
\$125.00	23	-	\$2,875.00	-	\$110.58
\$125.00	24	-	\$3,000.00	-	\$115.38
\$125.00	25	-	\$3,125.00	-	\$120.19
\$125.00	26	-	\$3,250.00	-	\$125.00
\$125.00	27	-	\$3,375.00	-	\$129.81
\$125.00	28	-	\$3,500.00	-	\$134.62
\$125.00	29	-	\$3,625.00	-	\$139.42
\$125.00	30	-	\$3,750.00	-	\$144.23

This payment will be in addition to an employee's base pay and will be received on the same checks he receives for his normal pay.

ARTICLE 23

UNIFORM AND MAINTENANCE ALLOWANCE

SECTION 1. Employees shall provide a flashlight and batteries, suitable boots and/or shoes for all uniforms and maintenance of uniforms (not including any part of turn-out clothing or firefighting related gear) at their own expense.

SECTION 2. The Employer shall repair or replace with like kind and quality any timepiece damaged or destroyed in the line of duty to a maximum of two hundred dollars (\$200) per incident.

SECTION 3. The employer shall reimburse employees for damage or destruction of cell phones up to three hundred and twenty five dollars (\$325.00).

SECTION 4. The Employer agrees to replace prescription eyeglasses or contact lenses damaged or destroyed in the line of duty at full value, up to four hundred dollars (\$400).

SECTION 5. Repair or replacement must be due to job required activities. Repair or replacement must not be due to employee neglect.

SECTION 6. In recognition and appreciation of their dedicated service to the Midwest City Fire Department, employees covered by this collective bargaining agreement will have the right to purchase his or her Structural Firefighting Helmet upon promotion or retirement. The employee will pay 10% of the original purchase price multiplied by the remaining years of life for the Helmet. A minimum of 10% of the original purchase price of the Helmet will be paid by the employee regardless of the remaining service life of the Helmet. NFPA Standard 1851 sets the service life of structural firefighting Helmets at ten (10) years from the date of manufacture.

The employee will have the right to purchase their badge and/or collar brass upon promotion or retirement for the "replacement price" of either or both items.

Employees who are terminated for disciplinary reasons will forfeit these rights.

ARTICLE 24

WAGES

SECTION 1. The pay plan contained in Addendum "A" attached to this Agreement shall be implemented effective July 1, 2016~~8~~ and shall run the course of this contract. This pay scale adds ~~2.3~~2.31% COLA increase to the amounts established within the previous 2015~~7~~/2016~~8~~ pay scale as reflected in Addendum "A(1)" of this collective bargaining agreement. Addendum A(2) reflects the four percent (4%) shift in the pension calculation to base salaries.

For the second year of this agreement the total Fund 040 revenues minus other income (such as insurance recoveries, internal budget transfers, grant funds etc.) must exceed original 2018-2019 Fund 040 budget by at least 3% on July 15, 2019; employees covered under the bargaining agreement shall receive a 2.25% across the board increase to the pay scale for FY 2019/2020 effective July 1, 2019 as reflected on Addendum A(3); or if

The original 2018-2019 Fund 040 budget is exceeded by 3.5% on July 15, 2019; employees covered under this agreement shall receive a 2.5% across the board increase to the pay scale for the FY 2019/2020 effective July 1, 2019 as reflected on Addendum A(4); or if

The original 2018-2019 Fund 040 budget is exceeded by 4.25% on July 15, 2019; employees covered under this agreement shall receive a 3.0% across the board increase to the pay scale for the FY 2019/2020 effective July 1, 2019 as reflected on Addendum A(5).

Should this **not** occur, both parties will move to begin negotiations in order to come to an agreement and the 120 day statutory notification requirement is waived. It is understood compensation is the only subject that will be open to negotiations should the above described event occur.

ARTICLE 25

INCENTIVE PAY

SECTION 1. The Employer agrees to pay \$~~57.69~~10.00 per pay period to registered EMTs Intermediate/Advance and \$20.00 per pay period to registered EMT Paramedics covered under this collective bargaining agreement. ~~assigned to the Operations and Training Section(s).~~ Provided, however, such payment shall be made only as long as the employee maintains the required certification or registration according to the State of Oklahoma Department of Health requirements. ~~–~~ The Employer further agrees to pay \$46.15 per pay period to registered EMTs who are assigned to the Prevention Section. Such payment shall be made only as long as the employee maintains the required

certification or registration according to State of Oklahoma Department of Health requirements.

SECTION 2. The Employer agrees to pay \$34.62 per pay period to those employees who are assigned to the Prevention Section and who have completed inspection and investigation training as approved by the Fire Chief. The Employer further agrees to pay \$23.08 per pay period to those employees who are assigned to the Operations Section of the Fire Department who have completed Inspection and Investigation training as approved by the Fire Chief. Such payment shall be made only as long as the employee completes eight (8) hours per year of continuing education in the field of inspections and/or investigations, which continuing education shall be at the Employer's expense.

SECTION 3. The City agrees to pay \$30.00 per pay period to those employees who possess an Associate Degree or \$40.00 per pay period to those employees who possess a Bachelor's Degree or \$50.00 per pay period to those employees who possess a Master's Degree. The degree must be acquired from an accredited college or university. Only the highest degree possessed will be paid for; provided, that those employees eligible to receive compensation under this section shall not include employees who have elected to participate in the City tuition reimbursement program.

SECTION 4. The City agrees to pay \$23.08 per pay period to certified EMS Instructors as long as they are performing those duties not to exceed one per shift. One of the EMS Instructors will be assigned as EMS coordinator by the Fire Chief. The City agrees to pay \$23.08 per pay period to one EMS Coordinator as long as he is performing those duties.

SECTION 5. The Employer agrees to pay \$46.15 per pay period to certified Hazardous Materials Technician Level Responders. Such payment shall be made as long as the employee completes 8 hours of continuing education each year as required and provided by the Midwest City Fire Department Training Section.

SECTION 6. The Employer agrees to pay \$23.08 per pay period to those employees who serve on each of the following committees: Safety, Training/EMS, Special Ops/SCBA, Apparatus, and Honor Guard.

The Employer also agrees to pay \$23.08 per pay period to each Assistant Chief serving as Committee Director. This payment is not accumulative based on number of committees served.

SECTION 7. The employer agree to pay \$23.08 per pay period to those employees assigned to the Prevention Section that are CLEET Certified

SECTION 8. The employer agrees to pay ~~\$46.15~~ \$72.70 per pay period for those employees assigned to the duties of acting Shift Commander (Ride-Out) as designated by the Shift Commander with one per shift.-

ARTICLE 26

MINOR MAINTENANCE

Minor maintenance is considered to be the normal upkeep of station equipment, apparatus and department vehicles as now performed by department personnel.

ARTICLE 27

DUES AND SUBSCRIPTIONS

- A. The Employer agrees to pay, based on individual employees' written authorization and direction, the Oklahoma State Firefighters Association (OSFFA) dues for members of the bargaining unit.
- B. The Employer agrees to pay the registration fees for all delegates to the annual OSFA convention. Employees serving as delegates for the annual OSFA convention shall be allowed training leave starting Wednesday morning at 7:00 a.m. and ending at the conclusion of the convention on Saturday. Employees are required to attend all meetings and activities associated with the convention.

ARTICLE 28

HEALTH BENEFITS

SECTION 1. Effective July 1, 2016~~7~~, the Employer agrees to pay the employees covered by this Agreement enrolled in the Health Plan ~~Options PPO Network \$ 189.92 for the employee, or \$350.01 for the employee and their dependent spouse, or \$229.38 for the employee and their dependent child(ren), or \$471.91 for the employee and all dependents in each of their 26 paychecks per year, which amount includes rollup, for employee and dependent health benefits.~~

~~The Employer agrees to pay the employees covered by this Agreement enrolled in the Health Plan Preferred PPO Network \$174.90~~182.43 for the employee, or ~~\$321.23~~338.34 for the employee and their dependent spouse, or ~~\$210.11~~222.52 for the employee and their dependent child(ren), or ~~\$433.54~~455.37 for the employee and all dependents in each of their 26 paychecks per year, which amount includes rollup, for employee and dependent health benefits.

SECTION 2. On January 1, 1999, all of the employees covered by this agreement will participate in the City Employees' Health Benefits Plan as new participants. The benefits and premiums will be non-negotiable. Premium payments will be made through the cafeteria plan.

SECTION 3. The Employer recognizes its responsibility under 51 O.S. section 151 et. seq. to indemnify employees from certain claims arising out of the performance of their duties and from the costs and expense incurred in defending said claims. The Employer states its intention to adhere to said statutory requirements.

SECTION 4. During the Contract year in the event that the Internal Revenue Service (IRS) issues any regulations or additional guidance that affects the Employee Health and Benefit Plan overall costs and/or premiums, the parties agree to reopen negotiations on Article 28 for the sole purpose of modification to the premium that is referenced in section one of the article.

In the event that there are increases to the costs of the Employee Health and Benefits Plan during the contract year, the City agrees to pay half the increase cost associated to the premiums by tier, with the employee paying the remaining half.

Additionally, the City agrees to the following provisions as concerns future employee and/or dependent insurance premium increases:

1. The City Manager will notify Local 2066, in writing, of any premium increase recommendations of the Insurance Committee that are being taken to the City Council for approval.
2. Said notification will specify the exact dollar amount of increase for the employee premium and/or for the dependent premium being recommended to the Council.
3. The written notice shall be delivered to Local 2066 prior to the date of the premium increase recommendation being presented to the City Council for approval.

Said written communication will not be intended to change in any manner any other relationship of the parties in regards to the health insurance programs or premiums, but will simply serve to give Local 2066 prior notice of the Health Insurance Committee's recommendations to the Council for approval.

ARTICLE 29

LIFE INSURANCE

SECTION 1. The Employer shall provide life insurance for members of the Fire Department with a basic benefit of thirty thousand dollars (\$30,000) and a double indemnity benefit for accidental death in the amount sixty thousand dollars (\$60,000).

SECTION 2. To have optional life insurance extended to members of the bargaining unit, the Union must have 100 percent (100%) of members elect to participate. The Employer shall pay fifty percent (50%) of any premium with the employee paying the remaining fifty percent (50%).

ARTICLE 30

HEALTH PHYSICAL

SECTION 1. The Employer agrees to pay the cost of a physical examination for employees ~~at~~. The Department will be divided as equally as possible into one-thirds (1/3) and in any given year one-third (1/3) of the department will be given the opportunity to attend an annual physical examination regardless of age.

~~Every 5 years — for employees age 18-39~~

~~Every 4 years — for employees age 40-49~~

~~Every 3 years — for employees age 50+~~

The Pphysical shall coincide with the needs of the physical fitness program. The physical shall consist of the following:

- History and physical
- Audiometric Testing
- Comprehensive Metabolic Panel (14) to include CBC and Lipid Battery (chemistry profile)
- X-Ray chest and spine ~~at employees discretion~~
- Lumbar-sacral spine X-ray at Employees Discretion
- Pulmonary function exam
- 12 Lead EKG and Exercise Treadmill Test
- Digital Prostrate Exam and PSA (if over 30)
- Static and Isoinertial Testing of Arm/Pull and Lifting tests
- A testicular exam for all male employees regardless of age
- Hepatitis C antibody screen
- Hepatitis B antibody screen
- Tdap immunization
- MMR Booster immunization at the employee's discretion
- Hepatitis A vaccination at the employee's discretion
- HIV Screen
- Calcium Scoring Test for all employees over 40

SECTION 2. If the Employer has reasonable cause to question a firefighter's physical fitness (health) to perform his/her assigned responsibilities, it may elect to require the individual to submit to a special physical examination at the Employer's expense or notify the individual employee of the necessity to review the results of the physical examination provided herein. If the employee refuses to release such results, the issue will be resolved through the grievance procedure, including arbitration, with the cost being borne equally by both parties.

ARTICLE 31

WORKING ON PERSONAL PROPERTY

Members of the bargaining unit shall be allowed, with the approval of the immediate supervisor, to work on personal items after regular working hours are over, provided there is no Fire Department business to be done. This type of activity may be performed under the following conditions:

- A. Work will not constitute a major overhaul of personal property.
- B. Work shall be limited to projects of a non-compensatory nature.
- C. No City equipment or supplies will be used.

ARTICLE 32

HOURS OF WORK

SECTION 1. Fire Personnel assigned to 24-hour shifts shall work on a 2912 hours per year in a twenty-seven (27) day work period under the three-platoon system. The 27 day work period will contain 216 hours of work of which 204 will be considered FLSA "straight time." The 24-hour shift shall commence at 0700 hours.

SECTION 2. Personnel assigned to 8-hour shift shall work a forty (40) hour average week in a 28-day work period.

ARTICLE 33

OVERTIME AND CALLBACK

SECTION 1. Overtime and callback for emergencies will be paid at the rate of time and one-half in dollars or compensatory time in accordance with FLSA regulations. Voluntary overtime for constant manning will be paid at time and one-half in dollars.

SECTION 2. Required off-duty training or meetings will be paid at time and one-half in dollars or compensatory time in accordance with FLSA regulations.

SECTION 3. Departmental personnel assigned to "on call status" shall be compensated at the rate of one and one-half times his rate of pay for a minimum of 2 hours if called back. Compensation shall be paid in accordance with FLSA regulations.

SECTION 4. At the discretion of the City Manager, employees may receive payment for overtime service. Rates of overtime pay shall be either at straight time or time and one-half their regular rate of pay for hours in a pay period. Whether an employee receives straight pay or time and one-half pay (or time) will depend on whether he or she was on normal work status during the entire pay period as described below:

Overtime Determination

Normal Work Status: At the end of the pay period, OT1 (straight time pay or compensatory time) or OT2 (time and one-half pay or compensatory time) shall be authorized depending on whether the employee was on normal work status during the entire pay period. An employee shall be considered on normal work status for any of the following:

1. When on duty performing assigned tasks
2. Vacation time
3. Civil or military leave
4. Holidays
5. Training leave
6. Compensatory time
7. Sick leave (if used for a doctor's appointment and approved by supervisor at least 72 hours in advance)
8. Blood leave
9. Union Leave
10. Voting Leave
11. Injury Leave

If an employee performs work in excess of his regularly scheduled hours in his normal pay period and are covered by the above normal work status criteria, overtime shall be compensated at the rate of time and one-half. The 12 hours of FLSA overtime in each 27 day period will be compensated at 1 ½ times the employee's base rate of pay. Employees' base rate of pay will include wage augments such as longevity pay, incentive pay, degree pay etc. Because the annual salary is divided by 2912 hours to compute a 24 hour worker's hourly wage, the "straight time" for these 12 hours has already been paid. The employee will therefore be compensated with the ½ portion of the base rate X the hours of FLSA overtime for each pay period.

Non-Work Status: An employee is considered not to be on normal work status for the following:

1. Unauthorized leave
2. Sick Leave
3. Extended Sick Leave
4. Suspension without pay
5. Emergency Leave
6. Leave of Absence
7. Leave without pay

If an employee is placed in one of the above non-work status during his normal work period, any overtime work is to be performed at straight time pay

SECTION 5. Members of the Prevention Section assigned to standby status on weekends or holidays shall be entitled to standby pay in the amount of \$50.00 per day while so assigned. In the event a member is called to duty while on standby status, he shall be compensated in accordance with Section 1 above and not receive the \$50.00 standby pay for that day.

ARTICLE 34

COMPENSATION AT SEPARATION

SECTION 1: An employee who resigns, retires or is dismissed, or dies in the line of duty is eligible and shall be compensated accordingly for all his accumulated overtime, compensatory time, holiday time, vacation, and sick time.

SECTION 2: Members of the bargaining unit agree to complete and submit to the City's Human Resources Office a Beneficiary Designation as to Final Wages and Benefits (BDFWB) found in the rear of the Collective Bargaining Agreement (CBA) in the event of a life change such as marriage, divorce, and/or in the event of the death of a beneficiary currently listed on the BDFWB form. The BDFWB form will be maintained in the member's Official Personnel File for record keeping purposes.

ARTICLE 35

DRUG FREE WORKPLACE ACT

The Employer will implement and conform to Public Law 100-690 The Drug Free Workplace Act of 1988. In accordance with the Act, the Employer will:

- A. Publish and distribute to workers a policy prohibiting illegal drugs in the workplace;
- B. Provide each employee a copy of the above policy;
- C. Establish "drug free awareness programs" to inform employees about the dangers of drug use in performance of their jobs; the penalties for using them at work; and the availability of drug-counseling programs;
- D. Require employees to notify the employer if they are convicted of any drug related crime;
- E. Punish convicted employees for drug violations or require their successful completion of a drug rehabilitation program.

ARTICLE 36

WAIVER

The parties acknowledge that during the negotiations which resulted in this Agreement, each had the unlimited right and opportunity to make demands and proposals with respect to all proper subjects of collective bargaining and that all such subjects have been discussed and negotiated upon and the agreements contained in this Agreement were arrived at after the free exercise of such rights and opportunities. Therefore, the Employer and the Union, for the life of this Agreement, each voluntarily and unqualifiedly waives the right and each agrees that the other shall not be obligated to further collectively bargain, with respect to any subject or matter not specifically referred to or covered in the Agreement, even though such subject or matter may not have been within the knowledge or contemplation of either or both of the parties at the time they negotiated or signed this Agreement.

ARTICLE 37

SUBSTANCE ABUSE POLICY

The parties agree to the Substance Abuse Policy attached hereto as Exhibit "A" for Fiscal Year 2009-10.

ARTICLE 38

PENSION BENEFITS

~~Section 1. The employer agrees to pay 4% of each employee's pensionable salary to the Oklahoma State Firefighters Retirement System in addition to the required 13% as the payment of the Employer's Contribution. Therefore, the total amount paid by the City of Midwest City will be 17% of each employee's pensionable salary and the employee will be required to pick up the remaining 4% for a total of 21% Section 2.~~

~~Effective November 1, 2013 the City Agrees to pay an additional 1% of each employee's pensionable salary making the Employer's total contribution into the Oklahoma State Firefighters Retirement System 18%, each employee will be required to contribute an additional 1% making the employee's total contribution 5%. Together the total contribution into the Oklahoma State Firefighters Retirement System will be the required 23% of the employee's pensionable salary.~~

~~Section 2. Those employees on Plan B will receive a four percent (4%) stipend each pay period in lieu of the forgoing benefit paid to other firefighters.~~

Effective Pay Period Ending 2/20/2019 the employer agrees to pay fourteen percent (14%) of each employee's total actual paid gross salary to the Oklahoma Firefighters Retirement System the employee will be required to pay the remaining nine percent (9%) for a total of twenty three percent (23%), in accordance with Title 11 O.S. § 49-122.

ARTICLE 39

SAVINGS CLAUSE

SECTION 1. If any provision of this Agreement or the application thereof to any person or circumstance is held invalid, the invalidity shall not affect other provisions or applications of this Agreement which can be given effect without the invalid provision or application and, to this end, the provisions of this Agreement are severable.

SECTION 2. In the event of invalidation of any article or section both the Employer and the Union agree to meet for the purpose of arriving at a mutually satisfactory agreement for such article or section within thirty (30) days of said invalidation.

SECTION 3. It is understood that the foregoing is a complete understanding of all the terms and conditions of employment to be governed by this Agreement during the contract period and it cannot be altered in any manner, save by the complete written concurrence of the parties subscribing hereto.

SECTION 4. Any appendices to this Agreement shall be numbered, dated and signed by the Employer and the Union, and shall be subject to the provision of this Agreement unless the terms of said appendices specifically delete or change a provision of this Agreement; and all appendices shall become part of this Agreement as if specifically set forth herein.

SECTION 5. It is understood that all time limits found within this Agreement may be extended by mutual concurrence.

SECTION 6. This Agreement shall be binding upon the successors and assignees of the parties hereto during the term of this contract, and no provisions or terms of obligations herein contained shall be modified, altered or changed in any respect except by mutual agreement of the parties in writing.

ARTICLE 40

Disciplinary Action Involving the Administrative Review Board

SECTION 1. Disciplinary action, for just cause, shall be solely for the good of the service, as a minimum the following procedure shall be followed as set forth by this article.

SECTION 2. All complaints lodged against member(s) of the Fire Department will be investigated. The allegations will be reduced to writing and will be presented to the employee at the time of the investigation. If appropriate discipline is issued it will be done at the end of a completed investigation; the employee will receive copies of the disciplinary action at the time the disciplinary action is issued.

SECTION 3. The employer will notify the employee, of any disciplinary action above the level of informal oral counseling. If an employee as a result of an investigation is going to be referred to the Administrative Review Board (ARB) with the recommendation for discipline to the level of suspension without pay, demotion, or termination of employment; the recommendation shall have written documentation supporting the recommendation of suspension without pay, demotion or termination of employment. The employee shall receive an identical copy of all documentation supporting the recommendation to the ARB. An identical copy of the recommendation and all supporting documentation will be given to the union representative, at the employee's request only. This information will be presented to both parties at the conclusion of the investigation prior to the ARB meeting. The employee will be given the opportunity to speak to the ARB if they so choose, the employee may have union representation present at their request.

(Intentionally left blank)

**ARTICLE 41
DURATION OF AGREEMENT**

THE AGREEMENT SHALL BECOME EFFECTIVE 12:01 A.M. July 1, 2016~~8~~, and shall remain in full force and effect until midnight June 30, 2017~~20~~.

IN WITNESS WHEREOF, the parties set their hands this 13~~12~~ day of ~~September~~February 2016~~9~~.

ATTEST:

THE CITY OF MIDWEST CITY, OKLAHOMA

City Clerk

Mayor

ATTEST:

MIDWEST CITY INTERNATIONAL
ASSOCIATION OF FIREFIGHTERS,
LOCAL #2066

Secretary

President

CORPORATE NEGOTIATOR
CITY OF MIDWEST CITY

Human Resources Director

APPROVED AS TO FORM AND LEGALITY this 13~~2~~ day of ~~September~~February 2016~~9~~.

City Attorney

MIDWEST CITY FIRE DEPARTMENT

EXHIBIT A

ARTICLE 23: SUBSTANCE ABUSE TESTING POLICY

PURPOSE: City government provides a variety of public services. The employees of the City are its most valuable resource since it is through their work that services are provided. When delivering services, the health and safety of the public and the employees are of paramount importance.

Drug and alcohol abuse is a serious problem which affects all segments of the community, including the workplace. Such abuse poses risks to members of the public and to City employees. Employees have the right to work in an alcohol and drug-free environment. Members of the public have the right to be free from the harmful effects of alcohol and drug abuse in the provision of public services. The policy of the City is to provide a safe work environment and to protect the public by ensuring a drug and alcohol-free workplace.

This policy also implements the 1995 Federal Highway Administration (FHWA) requirements for drug and alcohol testing for Commercial Drivers License holders; the Federal Transit Administration (FTA) rules for employees performing safety-sensitive work on CDL class vehicles; and the Oklahoma Workplace Drug and Alcohol Testing Act. **Any violation of this policy shall remove an applicant from consideration for employment and shall subject an employee to disciplinary action, up to and including termination.**

It is the City's policy to:

- A. Assure that all city employees are not impaired in their ability to perform assigned duties in a safe, healthy and productive manner.
- B. Create a workplace environment free from the adverse effects of drug and alcohol abuse or misuse.
- C. Prohibit the unlawful manufacture, distribution, dispensing, possession or use of controlled substances.
- D. Encourage employees to seek professional assistance any time personal problems, including alcohol or drug abuse or misuse, adversely affect their ability to perform their assigned work duties.

This policy is designed to:

- A. detect the use of prohibited drugs by urine testing.
- B. detect the misuse of alcohol by breath testing.
- C. deter the misuse of drugs and alcohol by providing education and training about the safety and health ramifications of substance abuse.

Revised: 5-1-00

This policy is intended to comply with all applicable federal and state regulations for prevention of prohibited drug and alcohol use. The U.S. Department of Transportation (DOT) has anecdote 49 CFR, Part 653 and Part 654, as amended, and 49 CFR, Part 40, as amended. The State of Oklahoma has anecdote Title 310, Chapter 638 and 40 O.S. Sections 551et Seq. which sets standards for drug and alcohol testing.

Scope. All City employees are subject to the provisions of this policy including employees who are required to have a current Commercial Drivers License (CDL) as a condition of employment. Employees performing safety-sensitive work on City vehicles (such as maintenance mechanics and their supervisors) are subject to the requirements of the Transit Administration Specific CDL provisions of this policy.

STATEMENTS OF POLICY:

Treatment and Rehabilitation. The City provides an Employee Assistance Program for employees needing treatment or rehabilitation as well as medical plan coverage for both inpatient and outpatient treatment. Accrued leave may be used for treatment and rehabilitation purposes.

Prohibitions. Employees who think they may have an alcohol or drug usage problem are urged to voluntarily seek confidential assistance from the Employee Assistance Program. This policy prohibits the following:

- A. The unauthorized use, possession, manufacture, distribution or sale of an illegal drug, controlled substance or drug paraphernalia on City property or while on City business, or in City supplied vehicles, or during working hours.
- B. The unauthorized use, possession, manufacture, distribution or sale of alcohol on City premises, or while on City business, or in City supplied vehicles, or during working hours.
- C. Storing any illegal drug, drug paraphernalia or any controlled substance whose use is unauthorized, or any container of alcohol, in or on City property (including vehicles). Unopened containers of alcohol in a private vehicle parked on City property shall not be a violation of this policy.

- D. Reporting to work, or working, while under the influence of illegal drugs or alcohol, whether on City premises or on City business, or in City supplied vehicles.
- E. Failing to notify the employee's supervisor, before beginning ~~work,~~ that work that the employee is taking medications or drugs which may interfere with the safe and effective performance of duties.
- F. Refusing to immediately submit to an alcohol or drug test when requested by a supervisor, in accordance with this policy.

Revised: 5-1-00

- G. Failing to provide, by the next work day following a request, a valid prescription for any drug or medication identified when the results of a drug test are positive. If the employee is taking prescription drugs, the prescription must be in the employee's name.
- H. Refusing to submit to an inspection as described in the Enforcement section of this policy when requested by a supervisor, in accordance with this policy.
- I. Failing to adhere to the requirements of any drug or alcohol treatment program in which the employee is enrolled: (a) as a condition of continued employment; or (b) pursuant to a written agreement between the City and the employee.
- J. Violating any criminal drug or alcohol statute while working or conviction under any criminal drug statute.
- K. Failing to notify the City of any arrest or conviction under any criminal drug or alcohol statute by the next work day following the arrest or conviction.

Managerial Responsibility for Enforcement. Managers and supervisors shall be responsible for enforcement of this policy. The City will provide training to all managers authorized to act under this policy in evaluating and working with substance abuse issues in the workplace.

Enforcement. When there is a reasonable suspicion to believe that an employee's job performance may be impaired by drugs or alcohol, the supervisor may: (a) direct the employee to submit to a drug/alcohol test; or (b) search, with or without employee consent, all areas and property in which the City maintains control or joint control with the employee.

Pre-Employment Testing. All applicants for position with the City, except temporary employees, are required to pass a pre-employment drug and alcohol test prior to being

hired. The test will be administered after a conditional offer of employment has been made and prior to any tentative start date. In some cases additional testing for CDL holders may be delayed until they are ready to begin driving a CDL vehicle or performing a safety-sensitive function on the job.

A positive test will exclude an applicant from being hired.

All applicants, except Police Officers and Firefighters will be tested under the procedures contained in this policy which are consistent with the procedures for CDL holders. The pre-employment protocols for police officers and firefighters are on file in the office of the Human Resources Director. Police and Fire applicants will be required to meet the test standards set by the Oklahoma Police and Fire Pension Systems.

Revised: 5-1-00

Reasonable Suspicion. "Reasonable suspicion" is a belief based on objective facts sufficient to lead a reasonable person to suspect that an employee is under the influence of drugs or alcohol so that the employee's ability to perform the functions of the job is impaired or that the employee's ability to perform his/her job safely is reduced. For example, any of the following, alone or in combination, may constitute reasonable suspicion:

1. Slurred speech;
2. Irregular or unusual speech patterns;
3. Impaired judgment;
4. Alcohol odor on breath;
5. Uncoordinated walking or movement;
6. Unusual or irregular behavior such as inattentiveness, listlessness, hyperactivity, hostility or aggressiveness;
7. Possession of alcohol or drugs.

Impairment. The supervisor shall directly observe the employee's behavior and document in writing the facts constituting reasonable suspicion. When circumstances permit, a second person shall also observe the employee to verify that there is a reasonable basis to believe that drug or alcohol impairment may be present. If possible, the supervisor shall question the employee with regard to the situation. When a determination is made that an employee may be impaired because of drug or alcohol use, the employee shall be relieved of his/her duties; and the employee shall be required to submit to a drug or alcohol test, as appropriate; he/she shall not be allowed to return to work until the test results have been reviewed and confirmed by the Medical Review Officer (MRO). The employee will be compensated for any time lost during this waiting period if the test result is confirmed negative.

The supervisor shall immediately notify the department head, or in his/her absence, the department head's designee. In the event that this person is not available, the supervisor shall immediately contact the Human Resources Director for review. Upon review, the department head or designee, or in his/her absence, the Human Resources

Director or designee, may authorize the supervisor to require a drug test. The Human Resources Director may be reached 24 hours a day at 740-1777.

Drug and Alcohol Testing. A drug test under this policy is a urinalysis (for drugs) and an evidential breathalyzer test (for alcohol) administered under approved conditions and procedures conducted for the sole purpose of detecting drugs and alcohol. Other methods to detect the presence of alcohol may be added at a later date if approved by the FHWA and the Oklahoma Workplace Drug and Alcohol Testing Act, including, but not limited to, blood/alcohol and saliva tests.

- A. The City shall conduct post-job offer, pre-employment testing examinations designed to prevent the hiring of individuals who use illegal drugs or abuse prescription drugs. All applicants, whether for full or part-time positions, shall submit to such testing as a condition of employment. Any applicant who fails or refuses to submit to such testing, or who tests a confirmed positive, shall be denied employment.

- B. An employee may be required to submit to drug or alcohol testing under any of the following conditions:
 - 1. When a reasonable suspicion exists that the employee has violated this policy.
 - 2. When a reasonable suspicion exists that the employee or another person has sustained an injury or property of the City has been damaged as a direct result of the employee's substance abuse;
 - 3. On a random selection or a scheduled, periodic basis for:
 - a. Police Officers and Firefighters;
 - b. employees with drug interdiction responsibilities;
 - c. employees authorized to carry firearms;
 - d. employees engaged in activities which directly affect the safety of others and those who supervise any of the above-enumerated employees (this includes all employees who drive vehicles either city or personal on behalf of the City of Midwest City);
 - e. ALL CDL holders;
 - f. work in direct contact with juveniles; and
 - g. Jailers

Revised: 9-26-05

- 4. When an employee, while operating a city vehicle or while using his/her personal vehicle on City business, is involved in an accident, he/she is subject to drug and alcohol testing.

New: 1-1-02

Following authorization for reasonable suspicion or post accident drug testing, the supervisor or other authorized person will transport the employee to the designated laboratory. An employee shall be ordered to submit to a test or an applicant for

employment shall be directed to test by the Human Resources Department.

In the case of an applicant for employment or follow up testing, the individual shall appear at the designated laboratory at the time scheduled by the Human Resources Department.

The individual (employee or applicant) will be interviewed by laboratory personnel prior to the sample collection to determine whether the subject is currently using drugs under medical supervision and/or taking over-the-counter medications which might reasonably impact the test.

The room where the sample is obtained must be private and secure. Documentation shall be maintained that the area has been searched and is free of any foreign substance. For all general employees, CDL holders and individuals tested under the reasonable suspicion standard, no observer shall be present when the sample is collected. Procedural actions shall be taken in all tests to ensure the sample is from the subject and was actually passed at the time noted on the record.

**Revised: 5-1-00
10-02**

Processing Urine Samples. Each step in the collection and processing of the urine specimen shall be documented to establish procedural integrity and the chain of custody. Unless specifically noted, all testing will be done using SAMHSA procedures and threshold levels.

Specimen samples shall be sealed and labeled. Samples shall be stored in a secure and refrigerated atmosphere. A large enough sample will be taken to allow for a second, follow-up test.

Any sample which has been adulterated or is shown to be a substance other than urine shall be reported as such. Any applicant or employee providing false information about a urine or breath specimen or who attempts to contaminate such sample shall be removed from consideration for hiring or shall be subject to discipline, up to and including termination.

Police Officers and Firefighters pre-employment testing will be done according to the drug/alcohol testing protocols that are on file in the office at the State Police or Fire Pension System. Confirmation testing will be conducted using Gas Chromatography-Mass Spectrometry. The urine sample shall be retained for 12 months by proper storage method to allow for further testing if necessary.

Drugs Tested. The laboratory shall test for the following drugs at levels that meet or exceed the limits hereafter set forth by the Oklahoma Workplace Drug and Alcohol Testing Act and Oklahoma State Health Department Regulations, Title 310, Chapter 638, as amended from time to time.

All specimens identified as positive on the initial test shall be confirmed using gas chromatography/mass spectrometry or its equivalent as approved by the Commissioner of Health.

Samples will be collected and tested only by laboratories certified by the State Board of Health. The sample collection will be performed under reasonable and sanitary conditions in sufficient quantity for splitting into two specimens. This procedure allows for subsequent independent analysis in the event of a challenge of a confirmed positive test.

Individual privacy will be respected in the process of sample gathering. However, procedures will be followed to reasonably reduce the likelihood for substitutions or tampering.

The City has contracted with a reputable, qualified facility which insures confidentiality of testing, maintains records of the chain of custody, provides the individual an opportunity to confidentially provide information that may affect the test results and follows procedures that insure an individual an opportunity to obtain a confirmation test.

The City pays for all cost of testing including confirmation tests. If the individual requests a retest in order to challenge a confirmed test, that individual pays the costs for retesting. Only if the retest reverses the original confirmed test is the City required to reimburse the individual.

Results of Drug Testing. The laboratory will review the results of the test and determine if the sample contains any illegal drug, or legal drug or alcohol at levels that would cause impairment or reveal its use in an illegal manner. The lab director will also review the medical history made available by the individual when a confirmed positive test could have resulted from a legally prescribed medication.

For all CDL holders, mechanics and other City employees, the results shall be forwarded immediately to the City designated Medical Review Officer (MRO) for further review. The Human Resources Department will send a copy of the drug testing results to the employee's home address or hold the results for the employee to pick up, at his/her option.

Evaluation of Legal Drug Use. In the case of prescriptive drug use that may affect an employee's ability to perform his/her job safely, the laboratory director or, in the case of employees and all CDL testing, the City's designated Medical Review Officer, will require the individual to provide by the next scheduled work day a bonafide verification of a valid current prescription for the drug identified. The applicant shall be dropped from eligibility or the employee will be subject to disciplinary action when:

- (a) Verification of a valid prescription is not provided;
- (b) The prescription provided is not in the subject's name.

Alcohol Level at .02. When there is a confirmed presence of any illegal drug, or legal

drug or alcohol (equal to or greater than .02) or, in the case of legal drugs, for which in the opinion of the Lab Director or City designated Medical Review Officer (MRO), no reasonable explanation or proof is provided, the subject shall be deemed to have failed the test. When there is a confirmed presence of alcohol at the .02 level, the employee is deemed to be unable to work safely. The employee will be considered unable to work and will be sent home for the remainder of his/her work shift. The employee shall take leave without pay. The employee will not be permitted to take sick leave, vacation leave, compensatory time or any other earned leave. The employee will return to work after a minimum period of 24 hours or upon the conclusion of any administrative investigation (whichever period of time is greater).

Job Applicants. In the case of job applicants, the lab director or City MRO shall notify the applicant of a positive test result. An opportunity to have the original urine sample retested at the applicant's expense shall be afforded. The applicant must request a re-test within 72 hours. If there is a confirmed positive test, the applicant shall be removed from eligibility for hire.

Pre-employment test results for Firefighters or Police Officers will be forwarded directly to the applicable State Pension System. A copy will be sent to the Human Resources Director.

Revised: 5-1-00

Employees. The employee shall be advised of the positive test result by the City Medical Review Officer. The employee shall be afforded the opportunity to have the *original* urine sample retested. Retests must be requested within a period of 72 hours after notification of an initial positive test by the MRO.

A re-test will be done by the original lab (at the City's expense) unless the employee wishes to pay for a re-test at a different laboratory. The second test must be done under SAMHSA procedures or, for CDL holders, by a SAMHSA certified lab. If the subject declines a re-test or the re-test confirms the results of the initial test, the Human Resources Director shall be notified and a determination of appropriate action shall be made.

Discipline. As with any issue of employee misconduct, an appropriate investigation and assessment of circumstances will be made. Any disciplinary action will be carried out in accordance with City Human Resources Policies.

A referral for evaluation by a substance abuse professional is mandatory when there is a positive test.

Negative Test Results. Employees who have been tested for drugs and alcohol, where no substance abuse was found, shall receive notice of such findings from the City Human Resources Department. A copy of this notice will not be placed in their Human Resources file, unless requested by the employee. A record of the negative results shall be placed in a confidential folder in a separate, secured file maintained by the Human Resources Department.

In the case of job applicants, the hiring department shall be notified by the Human Resources Department that the applicant is clear for hire.

Confidentiality. Laboratory reports of positive test results shall not appear in an employee's general Human Resources folder. Information of this nature will be placed in a separate confidential medical folder that will be maintained by the Human Resources Department.

The positive reports or test results shall be disclosed to the department head only on a need-to-know basis. Disclosures without patient consent, may also occur when: (1) the information is compelled by law or by judicial or administrative process; (2) the information has been placed at issue in a formal dispute between the City and the employee; (3) the information is to be used in administering an employee benefit plan such as for drug or alcohol treatment; (4) the information is needed by Human Resources for the diagnosis or treatment of the patient (employee) who is unable to authorize disclosure.

Record Retention Requirements. The City shall maintain all records related to drug and alcohol testing for each CDL holder in a secure location with controlled access. All documents sent by the laboratory or the collection site shall be kept.

Revised: 5-1-00

The following records shall be maintained for a minimum of five years:

- a. Records of alcohol test results indicating an alcohol concentration of .02 or greater.
- b. Records of verified positive drug test results.
- c. Documentation of refusal to take required alcohol and/or drug tests.
- d. Evaluations and referrals.
- e. Copy of annual report.

Records related to alcohol and drug collection process and training shall be maintained for a minimum of two years.

Records of negative and canceled drug test results and alcohol test results with a concentration of less than 0.02 shall be maintained for a minimum of one year. No records containing driver information required by this policy will be released except as follows:

- 1. Upon written request of the employee;
- 2. Upon written authorization of the employee;
- 3. Records may be disclosed to a decision-maker in a lawsuit,

grievance, or other proceeding initiated by or on behalf of the employee, including, but not limited to, a worker's compensation, unemployment compensation or other proceeding relating to a benefit sought by the employee.

Drug and Alcohol Testing for Commercial Drivers License (CDL) Holders. All employees of the City who are required to have a Commercial Drivers License (CDL) as part of their jobs are subject to drug and alcohol testing as required by the U. S. Department of Transportation through the Federal Highway Administration. The following procedures apply to CDL holders:

Pre-Employment Testing. All new employees who must have a CDL as a job requirement must pass a pre-employment drug and alcohol test prior to hire. The test will be administered after a conditional offer of employment has been made and prior to any tentative start date. This test will be conducted under the SAMHSA standards and protocols. See earlier sections of this policy for a list of drugs and confirmation levels. The test will involve an unobserved urine sample collection for drug testing and an evidential breathalyzer test administered by a Breath Alcohol Technician (BAT) for alcohol. The procedures and protocols are identical to those for all City employees covered above unless specifically noted. All urine drug testing will be conducted by a SAMHSA certified laboratory.

Revised: 5-1-00

Pre-Duty Use of Alcohol. Employees are prohibited from consuming alcohol for four (4) hours before going on duty.

This regulation from the FHWA applies to scheduled shifts and all on-call situations. If an employee cannot meet this requirement, it is his/her responsibility to tell the supervisor or person initiating the call-out that the employee cannot report to work.

Random Testing. During each calendar year, 50% of CDL holders will be tested on a random basis for the presence of drugs and alcohol. Approximately quarterly, although testing could occur anytime during the year, names of CDL holders will be drawn randomly to select individuals for drug and alcohol testing. These individuals will be scheduled for testing. All individuals will be required to go to a collection site for drug and alcohol testing. No advance warning will be given to employees regarding the date and time of the random test.

The collection, test results and the handling of any positive tests are the same as noted above for all employees.

Individuals who are scheduled to drive a CDL vehicle or perform a safety-sensitive function (such as a mechanic) on the day of the random test shall also take a breathalyzer test for alcohol.

Any accident involving a CDL holder must be immediately reported by the employee to his/her supervisor. The supervisor shall investigate the circumstances of the accident

and determine if there is reasonable suspicion to require a drug and alcohol test. Testing is mandated in the following circumstances:

- A) An accident that has resulted in the loss of human life.
- B) An accident in which the driver receives a citation and there is an injury requiring medical attention away from the scene of the accident.
- C) An accident in which the driver receives a citation.
- D) Any accident that property damage exceeds \$500.

Revised: 9-26-05

Additional rules under the Federal Transit Act apply to City mechanics who have worked on a CDL vehicle involved in an accident and their immediate supervisor. An employee in a safety sensitive position, such as a mechanic, is subject to drug and alcohol testing when, in the opinion of a supervisor, employee performance caused or contributed to the accident. For example, a mechanic would be tested when he/she worked on a vehicle's brakes just prior to an accident and a brake problem contributed to the accident.

A post accident drug and alcohol test should be completed as soon as possible. Drug testing must occur no later than 32 hours after the accident. Alcohol testing must occur no later than 8 hours after the accident. If more than two hours elapse before an alcohol test is administered, the City is required to prepare and maintain on file an explanation of why a test was not properly administered for the FHWA.

Revised: 5-1-00

A CDL driver involved in an accident is prohibited from consuming alcohol for 8 hours after the accident or until he/she has taken a drug and alcohol test.

Note: A Police Officer investigating an accident has legal authority under certain circumstances to order a blood sample to be taken for drug and alcohol testing.

Return to Work Testing. When an employee has tested positive for drugs or alcohol during a random or post accident test, the same provisions apply as for all employees in the section above on *Discipline and/or Treatment/Rehabilitation*. In addition, the following specific rules apply:

1. Employees will be referred to the Employee Assistance Program or to other substance abuse counseling as part of their return to work requirements.
2. The employee must comply with any recommended rehabilitation.
3. The employee must have a negative retest before being permitted to return to work.
4. Unannounced follow-up tests will be conducted at least 6 times

within the first 12 months after an employee returns to work.

5. Testing may be extended for a period of up to 60 months after return to work.

Written acknowledgment will be required from the employee stating that he/she will be subject to random and reasonable suspicion testing for a period not to exceed 60 months.

Failure to successfully complete a treatment process or to comply with the return to work standards shall be grounds for termination of employment.

Responsibilities of Employees

It is each employee's responsibility to determine from his/her healthcare provider whether or not any drug or substance the employee is taking would impair job performance.

It is also the responsibility of any employee who personally observes or has personal knowledge of another employee who is in a condition which impairs that employee's ability to perform his/her job duties or poses a hazard to the safety and welfare of him/herself, the public, other employees or equipment, to promptly report the incident to his/her immediate supervisor or any other supervisor in the employee's chain of command.

Revised: 5-1-00

Revised entire Article 9/01

CITY OF MIDWEST CITY

EMPLOYEE ASSISTANCE PROGRAM

The City of Midwest City is aware that many personal or health problems can and do interfere with an employee's ability to perform his/her job. These problems may include abuse of alcohol or drugs.

Employees whose job performance problems are not related to a lack of skill and who do not respond satisfactorily to the usual disciplinary procedures are often in need of the attention of professionals. With proper treatment, many troubled employees can be restored to a satisfactory level of job performance.

To assist these troubled employees, the City offers an Employee Assistance Program (EAP) as part of the Health Benefits Program. Assessment, counseling, referral and follow-up are provided for employees whose personal or health problems are interfering with their job performance. The cost of such services are the responsibility of the employee. Some costs may be covered by the health benefits program and details of coverage may be obtained from the Human Resources Department or the health benefits third party administrator. Also, the health benefits plan document provided to

you gives details of coverage. The EAP can be accessed by an employee without a referral by a supervisor. In a self referral, the employee contacts an EAP counselor directly.

The City's supervisors are responsible to confront an employee when they see changes in performance that suggest a substance abuse problem. The supervisor may suggest that the employee voluntarily seek help from the EAP or decide that the severity of the observed problem is such that an involuntary referral to the EAP is appropriate.

Informal referrals can take place at any time apart from or during the disciplinary process or if an employee confides in a supervisor that he/she is having problems of a substance abuse nature. In an informal referral, the supervisor will inform the employee of the benefits of the EAP and give the employee the needed information to contact a counselor. In an informal referral, the EAP counselor will not tell the supervisor whether the employee used the EAP and will not divulge any information to the supervisor about any visit with the employee.

Through a formal referral, the supervisor directs the employee to make use of the EAP. Failure to use the EAP may result in disciplinary action up to and including termination. In a formal referral, the supervisor or the Human Resources Director may contact an EAP counselor to discuss the employee's problem. The EAP counselor will ask the employee to sign a waiver allowing the counselor to call the supervisor or the Human Resources Director and tell him/her whether the employee saw the counselor and followed recommendations. No detailed information is revealed to the supervisor or the Human Resources Director.

Supervisors should not attempt to diagnose the nature of the employee's problem. However, they should be alert to changes in behavior that may signal a problem such as:

- ** absenteeism
- ** chronic lateness
- ** personality change
- ** decline in work quality
- ** unusual behavior

SUBORDINATION TO OTHER LAWS/REGULATIONS

All provisions of this policy are subordinate to all federal or state laws and regulations. Any changes in such rules or regulations shall be incorporated into this policy.

POLICY DISTRIBUTION

A substance abuse policy will be distributed to all current City employees and shall be included in the Human Resources Policies and Procedures Manual.

CONTACT PERSON:

Any questions about or assistance with any aspect of the Substance Abuse Policy should be directed to the Human Resources Director at 739-1235 during business hours or 740-1777 after hours, on weekends and holidays.

NEW: 8-1-96

Revised: 9/01

~~2002 - 2003 LONGEVITY SCHEDULE~~

~~Formula effective 12-1-92 is: .0005 x \$25,272 = \$12.64~~

<u>YEARS</u>	<u>DOLLARS PER MONTH</u>
6 x \$12.64 =	\$ 75.84
7 x \$12.64 =	88.48
8 x \$12.64 =	101.12
9 x \$12.64 =	113.76
10 x \$12.64 =	126.40
11 x \$12.64 =	139.04
12 x \$12.64 =	151.68
13 x \$12.64 =	164.32
14 x \$12.64 =	176.96
15 x \$12.64 =	189.60
16 x \$12.64 =	202.24
17 x \$12.64 =	214.88
18 x \$12.64 =	227.52
19 x \$12.64 =	240.16
20 x \$12.64 =	252.80
21 x \$12.64 =	265.44
22 x \$12.64 =	278.08
23 x \$12.64 =	290.72
24 x \$12.64 =	303.36
25 x \$12.64 =	316.00
26 x \$12.64 =	328.64
27 x \$12.64 =	341.28

ADDENDUM A(1): 2018-2019 FIRE PAY SCALE
EFFECTIVE 07/01/2018 Applied 2.31 ACROSS THE BOARD INCREASE

FIREFIGHTER		STEP 1	STEP 2	STEP 3	STEP 4	STEP 5	
	ANNUAL	42,593.77	45,529.66	48,425.98	51,344.51	52,339.97	
	BI-WEEKLY	1,638.22	1,751.14	1,862.54	1,974.79	2,013.08	
	HOURLY	14.6270	15.6352	16.6298	17.6320	17.9739	
SR. FIREFIGHTER		STEP 1	STEP 2	STEP 3	STEP 4	STEP 5	STEP 6
	ANNUAL	55,258.50	58,166.08	61,072.70	63,980.27	67,302.08	70,623.88
	BI-WEEKLY	2,125.33	2,237.16	2,348.95	2,460.78	2,588.54	2,716.30
	HOURLY	18.9761	19.9746	20.9728	21.9712	23.1120	24.2527
SERGEANT		STEP 1	STEP 2	STEP 3	STEP 4		
	ANNUAL	68,937.06	70,825.67	72,714.27	75,997.45		
	BI-WEEKLY	2,651.43	2,724.06	2,796.70	2,922.98		
	HOURLY	23.6734	24.3220	24.9706	26.0980		
LIEUTENANT		STEP 1	STEP 2	STEP 3	STEP 4		
	ANNUAL	77,555.52	79,147.06	80,770.14	82,428.63		
	BI-WEEKLY	2,982.90	3,044.12	3,106.54	3,170.33		
	HOURLY	26.6331	27.1796	27.7370	28.3065		
CAPTAIN		STEP 1	STEP 2	STEP 3	STEP 4		
	ANNUAL	83,265.44	84,976.07	86,722.41	88,505.77		
	BI-WEEKLY	3,202.52	3,268.31	3,335.48	3,404.07		
	HOURLY	28.5939	29.1813	29.7810	30.3935		
MAJOR		STEP 1	STEP 2	STEP 3	STEP 4		
	ANNUAL	90,326.47	92,185.15	94,083.41	96,020.93		
	BI-WEEKLY	3,474.10	3,545.58	3,618.59	3,693.11		
	HOURLY	31.0187	31.6570	32.3089	32.9742		
SHIFT COMMANDER (ASST. CHIEF)		STEP 1	STEP 2	STEP 3	STEP 4		
	ANNUAL	97,999.34	100,019.26	102,081.99	104,144.73		
	BI-WEEKLY	3,769.21	3,846.89	3,926.23	4,005.57		
	HOURLY	33.65362	34.347273	35.055629	35.763985		
TRAINING CHIEF		STEP 1	STEP 2	STEP 3	STEP 4		
	ANNUAL	97,999.34	100,019.26	102,081.99	104,144.73		
	BI-WEEKLY	3,769.21	3,846.89	3,926.23	4,005.57		
	HOURLY	33.6536	34.3473	35.0556	35.7640		
FIRE MARSHAL		STEP 1	STEP 2	STEP 3	STEP 4		
	ANNUAL	96,464.75	98,484.67	100,547.40	102,610.14		
	BI-WEEKLY	3,710.18	3,787.87	3,867.21	3,946.54		
	HOURLY	46.3773	47.3484	48.3401	49.3318		
FIRE PREVENTION		STEP 1	STEP 2	STEP 3	STEP 4	STEP 5	
	ANNUAL	74,356.66	76,274.64	78,018.36	79,761.87	83,262.89	
	BI-WEEKLY	2,859.87	2,933.64	3,000.71	3,067.76	3,202.42	
	HOURLY	35.7484	36.6705	37.5088	38.3471	40.0302	

NOTE: The City and the IAFF agreed to move the \$57.69 bi-weekly/\$1499.94 annual EMT incentive to the base pay scale. Therefore, \$1499.94 was added to each step of each rank. This did not include the Fire Prevention Ranks.

ADDENDUM A(2): 2018-2019 FIRE PAY SCALE
EFFECTIVE 07/01/2018 Applied 2.31% ACROSS THE BOARD INCREASE
EFFECTIVE PAY PERIOD ENDING 2/20/2019 4% PENSION SHIFT

FIREFIGHTER		STEP 1	STEP 2	STEP 3	STEP 4	STEP 5	
	ANNUAL	44297.522	47350.845	50363.022	53398.289	54433.574	
	BI-WEEKLY	1703.7508	1821.1863	1937.0393	2053.7804	2093.599	
	HOURLY	15.212061	16.260592	17.294994	18.337325	18.692848	
SR. FIREFIGHTER		STEP 1	STEP 2	STEP 3	STEP 4	STEP 5	STEP 6
	ANNUAL	57468.841	60492.722	63515.604	66539.486	69994.159	73448.83
	BI-WEEKLY	2210.34	2326.6432	2442.9078	2559.211	2692.083	2824.955
	HOURLY	19.735179	20.7736	21.811677	22.850098	24.036456	25.22281
SERGEANT		STEP 1	STEP 2	STEP 3	STEP 4		
	ANNUAL	71694.544	73658.7	75622.846	79037.352		
	BI-WEEKLY	2757.4824	2833.0269	2908.571	3039.8982		
	HOURLY	24.620379	25.294883	25.969384	27.141948		
LIEUTENANT		STEP 1	STEP 2	STEP 3	STEP 4		
	ANNUAL	80657.743	82312.939	84000.949	85725.775		
	BI-WEEKLY	3102.2209	3165.8823	3230.8057	3297.1452		
	HOURLY	27.698401	28.266806	28.84648	29.438796		
CAPTAIN		STEP 1	STEP 2	STEP 3	STEP 4		
	ANNUAL	86596.061	88375.11	90191.303	92046.003		
	BI-WEEKLY	3330.6177	3399.0427	3468.8963	3540.2309		
	HOURLY	29.737658	30.348595	30.972288	31.609204		
MAJOR		STEP 1	STEP 2	STEP 3	STEP 4		
	ANNUAL	93,939.53	95,872.55	97,846.74	99,861.77		
	BI-WEEKLY	3,613.06	3,687.41	3,763.34	3,840.84		
	HOURLY	32.2595	32.9233	33.6012	34.2932		
SHIFT COMMANDER (ASST. CHIEF)		STEP 1	STEP 2	STEP 3	STEP 4		
	ANNUAL	101,919.32	104,020.03	106,165.27	108,310.51		
	BI-WEEKLY	3,919.97	4,000.77	4,083.28	4,165.79		
	HOURLY	34.999765	35.721164	36.457854	37.194545		
TRAINING CHIEF		STEP 1	STEP 2	STEP 3	STEP 4		
	ANNUAL	101,919.32	104,020.03	106,165.27	108,310.51		
	BI-WEEKLY	3,919.97	4,000.77	4,083.28	4,165.79		
	HOURLY	48.9997	50.0096	51.0410	52.0724		
FIRE MARSHAL		STEP 1	STEP 2	STEP 3	STEP 4		
	ANNUAL	100,323.34	102,424.06	104,569.30	106,714.54		
	BI-WEEKLY	3,858.59	3,939.39	4,021.90	4,104.41		
	HOURLY	48.2324	49.2423	50.2737	51.3051		
FIRE PREVENTION		STEP 1	STEP 2	STEP 3	STEP 4	STEP 5	
	ANNUAL	77,330.92	79,325.63	81,139.10	82,952.34	86,593.40	
	BI-WEEKLY	2,974.27	3,050.99	3,120.73	3,190.47	3,330.52	
	HOURLY	37.1783	38.1373	39.0092	39.8809	41.6314	

NOTE: Effective pay period ending 2/20/2019 the City and the IAFF have agreed to shift 4% back to in lieu of the City paying 4% of the employee's contribution to the Okla. State Firefighters Retirement system. Refer to Article 38 of the CBA.

ADDENDUM A(3): 2019-2020 FIRE PAY SCALE
EFFECTIVE 07/01/2019 Applied 2.25% ACROSS THE BOARD INCREASE

FIREFIGHTER		STEP 1	STEP 2	STEP 3	STEP 4	STEP 5	
	ANNUAL	45294.216	48416.239	51496.19	54599.75067	55658.329	
	BI-WEEKLY	1742.0852	1862.163	1980.6227	2099.99041	2140.705	
	HOURLY	15.554332	16.626456	17.684131	18.74991438	19.113437	
SR. FIREFIGHTER		STEP 1	STEP 2	STEP 3	STEP 4	STEP 5	STEP 6
	ANNUAL	58761.89	61853.809	64944.705	68036.62408	71569.027	75101.43
	BI-WEEKLY	2260.0727	2378.9926	2497.8733	2616.793234	2752.6549	2888.517
	HOURLY	20.17922	21.241006	22.30244	23.3642253	24.577276	25.79033
SERGEANT		STEP 1	STEP 2	STEP 3	STEP 4		
	ANNUAL	73307.671	75316.021	77324.36	80815.69238		
	BI-WEEKLY	2819.5258	2896.77	2974.0138	3108.295861		
	HOURLY	25.174338	25.864018	26.553695	27.75264161		
LIEUTENANT		STEP 1	STEP 2	STEP 3	STEP 4		
	ANNUAL	82472.543	84164.98	85890.971	87654.60484		
	BI-WEEKLY	3172.0209	3237.1146	3303.4989	3371.330955		
	HOURLY	28.321615	28.902809	29.495526	30.10116924		
CAPTAIN		STEP 1	STEP 2	STEP 3	STEP 4		
	ANNUAL	88544.473	90363.55	92220.607	94117.03805		
	BI-WEEKLY	3405.5566	3475.5211	3546.9464	3619.886079		
	HOURLY	30.406756	31.031439	31.669165	32.32041142		
MAJOR		STEP 1	STEP 2	STEP 3	STEP 4		
	ANNUAL	96,053.17	98,029.68	100,048.29	102,108.66		
	BI-WEEKLY	3,694.35	3,770.37	3,848.01	3,927.26		
	HOURLY	32.9853	33.6640	34.3572	35.0648		
SHIFT COMMANDER (ASST. CHIEF)		STEP 1	STEP 2	STEP 3	STEP 4		
	ANNUAL	104,212.50	106,360.48	108,553.99	110,747.50		
	BI-WEEKLY	4,008.17	4,090.79	4,175.15	4,259.52		
	HOURLY	35.78726	36.52489	37.278156	38.03142198		
TRAINING CHIEF		STEP 1	STEP 2	STEP 3	STEP 4		
	ANNUAL	104,212.50	106,360.48	108,553.99	110,747.50		
	BI-WEEKLY	4,008.17	4,090.79	4,175.15	4,259.52		
	HOURLY	50.1022	51.1348	52.1894	53.2440		
FIRE MARSHAL		STEP 1	STEP 2	STEP 3	STEP 4		
	ANNUAL	102,580.62	104,728.60	106,922.11	109,115.62		
	BI-WEEKLY	3,945.41	4,028.02	4,112.39	4,196.75		
	HOURLY	49.3176	50.3503	51.4049	52.4594		
FIRE PREVENTION		STEP 1	STEP 2	STEP 3	STEP 4	STEP 5	
	ANNUAL	79,070.87	81,110.45	82,964.73	84,818.77	88,541.75	
	BI-WEEKLY	3,041.19	3,119.63	3,190.95	3,262.26	3,405.45	
	HOURLY	38.0148	38.9954	39.8869	40.7783	42.5682	

NOTE: The City and the IAFF Local 2066 have agreed that if the total Fund 040 Revenues minus other income exceeds the original FY 2018/19 fund 040 budget by at least 3% the employees covered under this CBA shall receive a 2.25% across the board increase to the pay scale for the FY 2019/20 effective July 1, 2019.

ADDENDUM A(4): 2019-2020 FIRE PAY SCALE
EFFECTIVE 07/01/2019 Applied 2.50% ACROSS THE BOARD INCREASE

FIREFIGHTER		STEP 1	STEP 2	STEP 3	STEP 4	STEP 5	
	ANNUAL	45404.96	48534.616	51622.098	54733.246	55794.413	
	BI-WEEKLY	1746.3446	1866.716	1985.4653	2105.1249	2145.939	
	HOURLY	15.592363	16.667107	17.727369	18.795758	19.160169	
SR. FIREFIGHTER		STEP 1	STEP 2	STEP 3	STEP 4	STEP 5	STEP 6
	ANNUAL	58905.562	62005.04	65103.494	68202.973	71744.013	75285.05
	BI-WEEKLY	2265.5985	2384.8092	2503.9805	2623.1913	2759.3851	2895.579
	HOURLY	20.228558	21.29294	22.356969	23.421351	24.637367	25.85338
SERGEANT		STEP 1	STEP 2	STEP 3	STEP 4		
	ANNUAL	73486.907	75500.167	77513.417	81013.286		
	BI-WEEKLY	2826.4195	2903.8526	2981.2853	3115.8956		
	HOURLY	25.235888	25.927255	26.618618	27.820496		
LIEUTENANT		STEP 1	STEP 2	STEP 3	STEP 4		
	ANNUAL	82674.187	84370.763	86100.973	87868.919		
	BI-WEEKLY	3179.7764	3245.0293	3311.5759	3379.5738		
	HOURLY	28.390861	28.973476	29.567642	30.174766		
CAPTAIN		STEP 1	STEP 2	STEP 3	STEP 4		
	ANNUAL	88760.963	90584.487	92446.085	94347.153		
	BI-WEEKLY	3413.8832	3484.0187	3555.6187	3628.7367		
	HOURLY	30.4811	31.10731	31.746595	32.399434		
MAJOR		STEP 1	STEP 2	STEP 3	STEP 4		
	ANNUAL	96,288.02	98,269.37	100,292.91	102,358.31		
	BI-WEEKLY	3,703.39	3,779.59	3,857.42	3,936.86		
	HOURLY	33.0659	33.7463	34.4412	35.1505		
SHIFT COMMANDER (ASST. CHIEF)		STEP 1	STEP 2	STEP 3	STEP 4		
	ANNUAL	104,467.30	106,620.53	108,819.40	111,018.28		
	BI-WEEKLY	4,017.97	4,100.79	4,185.36	4,269.93		
	HOURLY	35.874759	36.614193	37.369301	38.124408		
TRAINING CHIEF		STEP 1	STEP 2	STEP 3	STEP 4		
	ANNUAL	104,467.30	106,620.53	108,819.40	111,018.28		
	BI-WEEKLY	4,017.97	4,100.79	4,185.36	4,269.93		
	HOURLY	50.2247	51.2599	52.3170	53.3742		
FIRE MARSHAL		STEP 1	STEP 2	STEP 3	STEP 4		
	ANNUAL	102,831.43	104,984.66	107,183.53	109,382.41		
	BI-WEEKLY	3,955.05	4,037.87	4,122.44	4,207.02		
	HOURLY	49.4382	50.4734	51.5305	52.5877		
FIRE PREVENTION		STEP 1	STEP 2	STEP 3	STEP 4	STEP 5	
	ANNUAL	79,264.20	81,308.77	83,167.57	85,026.15	88,758.24	
	BI-WEEKLY	3,048.62	3,127.26	3,198.75	3,270.24	3,413.78	
	HOURLY	38.1078	39.0908	39.9844	40.8780	42.6722	

NOTE: The City and the IAFF Local 2066 have agreed that if the total Fund 040 Revenues minus other income exceeds the original FY 2018/19 fund 040 budget by at least 3.5% the employees covered under this CBA shall receive a 2.5% across the board increase to the pay scale for the FY 2019/20 effective July 1, 2019.

ADDENDUM A(5): 2019-2020 FIRE PAY SCALE
EFFECTIVE 07/01/2019 Applied 3.0% ACROSS THE BOARD INCREASE

FIREFIGHTER		STEP 1	STEP 2	STEP 3	STEP 4	STEP 5	
	ANNUAL	45,626.45	48,771.37	51,873.91	55,000.24	56,066.58	
	BI-WEEKLY	1,754.86	1,875.82	1,995.15	2,115.39	2,156.41	
	HOURLY	15.6684	16.7484	17.8138	18.8874	19.2536	
SR. FIREFIGHTER		STEP 1	STEP 2	STEP 3	STEP 4	STEP 5	STEP 6
	ANNUAL	59,192.91	62,307.50	65,421.07	68,535.67	72,093.98	75,652.30
	BI-WEEKLY	2,276.65	2,396.44	2,516.20	2,635.99	2,772.85	2,909.70
	HOURLY	20.3272	21.3968	22.4660	23.5356	24.7575	25.9795
SERGEANT		STEP 1	STEP 2	STEP 3	STEP 4		
	ANNUAL	73,845.38	75,868.46	77,891.53	81,408.47		
	BI-WEEKLY	2,840.21	2,918.02	2,995.83	3,131.10		
	HOURLY	25.3590	26.0537	26.7485	27.9562		
LIEUTENANT		STEP 1	STEP 2	STEP 3	STEP 4		
	ANNUAL	83,077.48	84,782.33	86,520.98	88,297.55		
	BI-WEEKLY	3,195.29	3,260.86	3,327.73	3,396.06		
	HOURLY	28.5294	29.1148	29.7119	30.3220		
CAPTAIN		STEP 1	STEP 2	STEP 3	STEP 4		
	ANNUAL	89,193.94	91,026.36	92,897.04	94,807.38		
	BI-WEEKLY	3,430.54	3,501.01	3,572.96	3,646.44		
	HOURLY	30.6298	31.2591	31.9015	32.5575		
MAJOR		STEP 1	STEP 2	STEP 3	STEP 4		
	ANNUAL	96,757.72	98,748.73	100,782.14	102,857.62		
	BI-WEEKLY	3,721.45	3,798.03	3,876.24	3,956.06		
	HOURLY	33.2272	33.9110	34.6093	35.3220		
SHIFT COMMANDER (ASST. CHIEF)		STEP 1	STEP 2	STEP 3	STEP 4		
	ANNUAL	104,976.90	107,140.63	109,350.23	111,559.83		
	BI-WEEKLY	4,037.57	4,120.79	4,205.78	4,290.76		
	HOURLY	36.0498	36.7928	37.5516	38.3104		
TRAINING CHIEF		STEP 1	STEP 2	STEP 3	STEP 4		
	ANNUAL	104,976.90	107,140.63	109,350.23	111,559.83		
	BI-WEEKLY	4,037.57	4,120.79	4,205.78	4,290.76		
	HOURLY	50.4697	51.5099	52.5722	53.6345		
FIRE MARSHAL		STEP 1	STEP 2	STEP 3	STEP 4		
	ANNUAL	103,333.04	105,496.78	107,706.38	109,915.98		
	BI-WEEKLY	3,974.35	4,057.57	4,142.55	4,227.54		
	HOURLY	49.6793	50.7196	51.7819	52.8442		
FIRE PREVENTION		STEP 1	STEP 2	STEP 3	STEP 4	STEP 5	
	ANNUAL	79,650.85	81,705.40	83,573.27	85,440.91	89,191.20	
	BI-WEEKLY	3,063.49	3,142.52	3,214.36	3,286.19	3,430.43	
	HOURLY	38.2937	39.2814	40.1795	41.0774	42.8804	

NOTE: The City and the IAFF Local 2066 have agreed that if the total Fund 040 Revenues minus other income exceeds the original FY 2018/19 fund 040 budget by at least 4.25% the employees covered under this CBA shall receive a 3% across the board increase to the pay scale for the FY 2019/20 effective July 1, 2019.



Collective Bargaining Agreement
Local 2066 / City of Midwest City
Grievance Form



Name of Grievant:

Date of Incident:

Rank:

Date Grievant Aware of Incident:

Please complete a narrative with the facts supporting the grievance (attach additional pages if needed):

Please specify the article(s) and section(s) of the contract believed to be violated:

Please note the resolution requested:

Grievant Signature:

Date:

Step one (1) of the grievance process is to discuss the grievance with the employee's immediate supervisor, the immediate supervisor shall respond within six (6) days of discussing the grievance with his/her employee in writing. If not resolved, the employee can submit the grievance to the Fire Chief.

Assistant Chief	Date discussed w/ Emp.	Date of written response

Step two (2) if the grievance is not resolved in step 1 above, the employee has the right to submit his/her grievance in writing within six (6) calendar days citing the CBA article violation, and remedy request to the Fire Chief; who then has six calendar days to respond in writing.

Fire Chief:	Date Submitted to Fire Chief:	Date of the Fire Chief's Response:	
Filed by:	<input type="checkbox"/> Local 2066	<input type="checkbox"/> Grievant	

Step three (3) if the grievance is not resolved in step 2, the grievance shall be submitted to the Labor Relations Officer in writing within six (6) calendar days. The LRO has ten (10) days to meet with the Union and Fire Chief to discuss the grievance. The LRO then has six (6) calendar days to respond in writing to the employee.

Labor Relations Officer:	Date Submitted to LRO:	Date of the LRO's Response:	
--------------------------	------------------------	-----------------------------	--

Step four (4) if the grievance is not resolved in step 3, the employee has the right to submit his/her grievance to the City Manager in writing within six (6) days. The City Manager has six (6) calendar days to respond in writing to the employee. If the grievance is not settled in this step the union or the City can by mutual agreement ask for Mediation; if not resolved through Mediation then the union can submit the grievance for impartial arbitration in accordance with Article 15 of the CBA.

City Manager:	Date Submitted to City Manager:	Date of the City Manager's Response:	
---------------	---------------------------------	--------------------------------------	--

Please note in this section any information pertinent to the resolution of the grievance (i.e. agreements to change hearing dates or time limitations):

Attach additional pages if needed

The City of Midwest City

BENEFICIARY DESIGNATION AS TO FINAL WAGES AND BENEFITS FORM

I understand that Oklahoma State law Title 40 Stat. §165.3a and Title 62 Stat. §304.2¹ allow me the option of designating a beneficiary to receive my final wages and termination pay in the event of my death while still gainfully employed by the City of Midwest City. If I do not designate a beneficiary and keep the beneficiary current, and die while still gainfully employed by the City of Midwest City, not more than Three Thousand Dollars (\$3,000.00) of my final wages and termination pay will be paid to my surviving spouse, or dependent child(ren), as allowed by state law and the remainder will be paid to my estate.

I understand that I can change or cancel my beneficiary designation at any time. I further understand that it is my sole responsibility to change my beneficiary designation when a life event occurs in my life such as marriage, divorce or death of a beneficiary currently listed on this form. The City is not responsible if the form is not correct or current.

I designate: _____ Percentage
 ----- %
 Print Name Relationship

_____ %
 Address City & St. Zip Code

 Print Name Relationship

_____ %
 Address City & St. Zip Code

 Print Name Relationship

_____ %
 Address City & St. Zip Code

As my beneficiary(ies) the individuals listed above shall receive my final wages and termination pay as designated above, in the event of my death while gainfully employed by the City. In the event any of the above designated beneficiary(ies) should predecease me, or has been divorced from me prior to my death, I designate the following person as my contingent beneficiary to receive that designated percentage of my final wages and termination pay in the event of my death while still gainfully employed by the City..

I designate _____ as my contingent beneficiary.

 Print Name Relationship

 Address City & St. Zip

_____ I decline to designate a beneficiary with respect to my final wages and termination pay.

 Print Name Employee Signature Date

Reference: 40 Okla. Stat. §165.3a
 62 OKia. Stat. §304.2

Form Creation 04/23/2018



NEW BUSINESS/
PUBLIC DISCUSSION





EXECUTIVE SESSION





Assistant City Manager

100 N. Midwest Boulevard
Midwest City, OK 73110

Office: 405.739.1201

www.midwestcityok.org

MEMORANDUM

TO: Honorable Mayor and Council

FROM: Tim Lyon, Assistant City Manager

DATE: July 24, 2018

RE: Discussion and consideration of (1) entering into executive session, as allowed under 25 O.S., § 307(B)(4), to discuss *Robert Toney, et al., v. City of Midwest City*, Case No. CJ-2015-3307, and (2) in open session, authorizing the city manager to take action as appropriate based on the discussion in executive session.

Appropriate information will be provided during executive session.

Tim Lyon
Assistant City Manager



FURTHER INFORMATION



Notice of the Midwest City Sidewalk Committee meeting was filed with the Midwest City Clerk and a copy of the agenda for the meeting was posted in the lobby of City Hall at least 24 hours in advance of the meeting.

**MINUTES OF MIDWEST CITY
SIDEWALK COMMITTEE
MEETING
January 22nd, 2019, 5:30 PM**

The meeting of the Midwest City Sidewalk Committee was held in the Community Development Conference Room, Midwest City, Oklahoma County, Oklahoma, on January 22nd, 2019 at 5:00 p.m., with the following members:

Espaniola Bowen, Chair
Sean Reed, Vice Chair
Matt Dukes, Mayor

Staff present: Patrick Menefee, City Engineer
Brandon Bundy, Assistant City Engineer

The meeting was called to order by the Chairman Dawkins.

A. MINUTES

Motion was made by Sean Reed and seconded by Matt Dukes to approve the minutes of the January 23rd, 2018 meeting. Voting aye: all present Nay: none. Motion carried.

B. DISCUSSION ITEMS

1. Discussion and consideration of financial report of Sidewalk Fee Fund and the Sidewalk/Trails Sales Tax Revenue Fund.

Patrick Menefee referred to the memo included in the agenda packet. Reported was the fund balance, what was constructed since last year's meeting, and the anticipated projects upcoming this budget year.

Since the item was information only, no action was taken on this item.

2. Discussion and consideration of a status report of Midwest City's Trail Projects funded through ODOT.

Patrick Menefee referred to the memo included in the agenda packet. Reported on the anticipated projects upcoming this budget year.

Since the item was information only, no action was taken on this item.

3. Discussion and consideration of a status report of the Midwest City ADA Transition Plan.

Patrick Menefee referred to the memo included in the agenda packet. Reported was the fund balance, what was constructed since last year's meeting, and the anticipated projects upcoming this budget year.

Sidewalk Committee Minutes

Since the item was information only, no action was taken on this item.

4. Discussion and consideration of recommending sidewalk projects for construction for calendar year 2018 utilizing the Sidewalk Fee Fund and the Sidewalk/Trails Sales Tax Revenue.

The memo was reviewed from the agenda packet. Current funds were reviewed. It was recommended to not construct any sidewalk projects this year and allow funds to build.

Discussion continued among the committee members.

Motion was made by Sean Reed, seconded by Matt Dukes, to recommend to the City Council there be no new sidewalk projects this year due to low Sidewalk Fund and Sidewalk /Trails Sales Tax Revenue Fund Fees being available. Voting aye: all present. Nay: none. Motion carried.

C. NEW BUSINESS / PUBLIC DISCUSSION

No further items were discussed.

D. ADJOURNMENT

There being no further business, a motion was made by Sean Reed, seconded by Matt Dukes, to adjourn the meeting. Voting aye: all present. Nay: none. Motion carried. Meeting adjourned at 5:45 p.m.

Espaniola Bowen, Chair



Joanne Horn, City Prosecutor
100 N. Midwest Boulevard
Midwest City, OK 73110
JHorn@MidwestCityOK.org
Office: 405.739.1284 / Fax: 405.869.8680
www.midwestcityok.org

Memorandum

TO: Honorable Mayor and Council

FROM: Joanne Horn, City Prosecutor

DATE: February 12, 2019

SUBJECT: Discussion and consideration of passing an ordinance amending the Midwest City Code, Chapter 28, Offenses – Miscellaneous, Article IV, Offenses Against Property, Section 28-57.1, False checks, to include violations less than \$1,000 in the definition of a misdemeanor ; and providing for repealer and severability.

The proposed amendment fills a gap created by a change in Oklahoma State Statute, 22 O.S. § 1541.1, which defined a new upper limit for a charge of misdemeanor false checks as “less than \$1,000.” Currently, ordinances do not permits the City to press charges against people who present a false check valued between \$500 and \$1,000.

Staff recommends approval.

Joanne Horn, City Prosecutor

ORDINANCE NO. _____

AN ORDINANCE AMENDING THE MIDWEST CITY MUNICIPAL CODE 3005, CHAPTER 28, OFFENSES-MISCELLANEOUS, ARTICLE IV – OFFENSES AGAINST PROPERTY, SECTION 28-57.1, FALSE CHECKS, AND PROVIDING FOR REPEALER AND SERVERABILITY.

BE IT ORDAINED BY THE COUNCIL OF THE CITY OF MIDWEST CITY, OKLAHOMA:

ORDINANCE

SECTION 1. That the Midwest City Municipal Code, Chapter 28, Offenses – Miscellaneous, Article IV – Offenses Against Property, Section 28-57.1 is hereby amended to read as follows:

Sec. 28-57.1. False checks.

(a) Every person who, with intent to cheat or defraud, obtains or attempts to obtain from any person, firm, business, corporation or other entity any money, property or other valuable benefit of a value of less than one thousand dollars (\$1,000.00), by means or use of false or bogus check, shall be guilty of an offense and upon conviction thereof, shall be punished by a fine or imprisonment in accordance with section 1-15 of this Code, plus costs, or by both such fine and imprisonment.

(b) For purposes of this section, intent shall be deemed under the following circumstances:

- (1) Presentation of a check or draft written on a closed account;
- (2) Presentation of a check or draft on a fictitious account;
- (3) Presentation of a check or draft not belonging to the person signing the check or draft;
- (4) Presentation of a check or draft without the knowledge or consent of the account holder;
- (5) Presenting a check to secure the release of a person as payment of a bond in the municipal jail which is insufficient to cover the amount of the check; or
- (6) Placing a "stop pay" order on any check presented for goods, services or any item of value without justifiable cause.

1 Section 2. REPEALER. All ordinances or parts of ordinances in conflict herewith are hereby
2 repealed.

3
4 Section 3. SEVERABILITY. If any section, sentence, clause, or portion of this ordinance is for
5 any reason held to be invalid, such decision shall not affect the validity of the remaining
6 provisions of the ordinance.

7 PASSED AND APPROVED by the Mayor and Council of the City of Midwest City, Oklahoma, on the
8 _____ day of _____, 2019.

9 THE CITY OF MIDWEST CITY, OKLAHOMA

10
11
12 _____
13 MATTHEW D. DUKES, II, Mayor
14

15
16 ATTEST:

17
18 _____
19 SARA HANCOCK, City Clerk
20

21 Approved as to form and legality this _____ day of February, 2019.
22

23 _____
24 HEATHER POOLE, City Attorney

1 Section 2. REPEALER. All ordinances or parts of ordinances in conflict herewith are hereby
2 repealed.

3
4 Section 3. SEVERABILITY. If any section, sentence, clause, or portion of this ordinance is for
5 any reason held to be invalid, such decision shall not affect the validity of the remaining
6 provisions of the ordinance.

7 PASSED AND APPROVED by the Mayor and Council of the City of Midwest City, Oklahoma, on the
8 ____ day of _____, 2019.

9 THE CITY OF MIDWEST CITY, OKLAHOMA

10
11
12 _____
13 MATTHEW D. DUKES, II, Mayor
14

15
16 ATTEST:

17
18 _____
19 SARA HANCOCK, City Clerk
20

21 Approved as to form and legality this ____ day of February, 2019.
22

23 _____
24 HEATHER POOLE, City Attorney



Joanne Horn, City Prosecutor
100 N. Midwest Boulevard
Midwest City, OK 73110
JHorn@MidwestCityOK.org
Office: 405.739.1284 / Fax: 405.869.8680
www.midwestcityok.org

Memorandum

TO: Honorable Mayor and Council

FROM: Joanne Horn, City Prosecutor

DATE: February 12, 2019

SUBJECT: Discussion and consideration of passing an ordinance amending the Midwest City Code, Chapter 24, Motor Vehicles, Article II, Administration and Enforcement, Division 2, Vehicle Impoundment, Section 24-44, Authorized, to permit the Police Department to tow a vehicle when the license plate has been altered or the officer has probable cause to believe the vehicle is not insured; and providing for repealer and severability.

The proposed amendment permits the Police Department to tow a motor vehicle when:

- (1) the license plate has been altered, pursuant to 47 O.S. §1115.1; or
- (2) the officer has probable cause to believe the vehicle is not insured, pursuant to 47 O.S. §7-606.

Staff recommends approval.

Joanne Horn, City Prosecutor

1 **ORDINANCE NO. _____**

2
3 **AN ORDINANCE AMENDING THE MIDWEST CITY MUNICIPAL CODE 3041,**
4 **CHAPTER 24, MOTOR VEHICLES, ARTICLE II, ADMINISTRATION AND**
5 **ENFORCEMENT, DIVISION 2, VEHICLE IMPOUNDMENT, SECTION 24-44,**
6 **AUTHORIZED, AND PROVIDING FOR REPEALER AND SERVERABILITY.**
7

8 BE IT ORDAINED BY THE COUNCIL OF THE CITY OF MIDWEST CITY, OKLAHOMA:
9

10 **ORDINANCE**

11
12 SECTION 1. That the Midwest City Municipal Code, Chapter 24, Motor Vehicles, Article II,
13 Administration and Enforcement, Division 2, Vehicle Impoundment, Section 24-44, Authorized,
14 is hereby amended to read as follows:

15
16 **Sec. 24-44 Authorized**

17 (a) Members of the police department are hereby authorized to remove a vehicle from any
18 street, highway, private property or public property to a storage facility as provided for in
19 section 24-44.1 of this Code under the following circumstances:

20 (1) When any vehicle is left unattended upon any public right-of-way and is so parked
21 as to constitute a hazard or obstruction to the normal movement of traffic or parked
22 where parking is prohibited;

23 (2) When a derelict vehicle has been parked upon public right-of-way for a period of
24 seventy-two (72) hours;

25 (3) When a vehicle has been parked on private property without the consent of the
26 owner or occupant of the property in violation of section 28-56 of this Code;

27 (4) When any vehicle is left abandoned upon public right-of-way in excess of three (3)
28 days from the date it was first reported or observed by officers;

29 (5) When officers recover a vehicle reported stolen and the owner cannot be located, is
30 unable or unwilling to effect the removal of the vehicle within a reasonable amount of
31 time not to exceed one (1) hour, or the preservation and collection of evidence
32 requires removal;

1 (6) Where the vehicle has any evidentiary value, has directly or indirectly been
2 involved in the commission of a crime, has been used to transport any person who has
3 committed any offense involving the use of a firearm, or was directly or indirectly
4 associated with a drive-by shooting;

5 (7) When a police officer effects the arrest of the owner or operator of a vehicle out of
6 said vehicle, and no person immediately present can lawfully or reasonably be given
7 custody of such vehicle;

8 (8) When the vehicle bears a license plate which has expired for a period in excess of
9 ninety (90) days, bears a license plate which has been altered or tampered with, or
10 bears a temporary paper tag which has been altered or expired for a period in excess of
11 ninety (90) days, or bears no license plate which would be in conformance with the
12 Oklahoma Vehicle License Act (47 O.S. § 1101, et seq.); ~~or~~

13 (9) Any place, including place of residence, when a police officer effects the arrest of
14 the operator of the vehicle, out of said vehicle, and the operator is found to have
15 operated the vehicle under any of the following violations: reckless driving, careless
16 driving, driving under the influence of drugs or alcohol, driving while impaired,
17 driving under a suspended, revoked or denied license, driving with no state driver's
18 license, eluding a police officer, duty to give information and render aid, or otherwise
19 involved in a hit-and-run accident, or ~~where applicable under subsection (b) of this~~
20 ~~section.~~

21 (10) When the officer has probable cause to believe a vehicle is not insured in
22 compliance with Oklahoma Compulsory Insurance Law, unless the sole basis for the
23 probable cause is the inability to verify insurance through the online verification
24 system.

25 ~~(b) Members of the police department shall remove a vehicle from any street, highway,~~
26 ~~private property or public property to a storage facility as provided for in section 24-44.1 of~~
27 ~~this Code., when the person operating said vehicle fails to produce valid security verification~~
28 ~~in addition to committing any one (1) of the following violations: reckless driving, careless~~
29 ~~driving, driving under the influence of drugs or alcohol, driving while impaired, driving under~~
30 ~~a suspended license, driving with an invalid driver's license, driving with no state driver's~~
31 ~~license, driving with an expired, improper or no tag displayed, avoiding a traffic stop, duty to~~

1 give information and render aid or otherwise involved in a hit and run accident, or eluding a
2 police officer where it involves the use of the subject vehicle; or
3 ~~(e) When any owner or operator fails to comply with the Compulsory Insurance Law and a~~
4 ~~requesting law enforcement officer is unable to verify a valid and current security verification~~
5 ~~through the online verification system, the law enforcement officer issuing the citation may seize~~
6 ~~the vehicle being operated by the person and cause the vehicle to be towed and stored as provided~~
7 ~~for in section 24-44.1 of this code, if the officer has probable cause to believe that the vehicle is~~
8 ~~not insured as required by the Compulsory Insurance Law of this state. If the operator of the~~
9 ~~vehicle produces what appears to be a valid security verification form and the officer is unable to~~
10 ~~confirm compliance through the online verification system or noncompliance by a subsequent~~
11 ~~investigation, the officer shall be prohibited from seizing the vehicle and causing such vehicle to~~
12 ~~be towed and stored.~~ _____
13
14

15 Section 2. REPEALER. All ordinances or parts of ordinances in conflict herewith are hereby
16 repealed.
17

18 Section 3. SEVERABILITY. If any section, sentence, clause, or portion of this ordinance is for
19 any reason held to be invalid, such decision shall not affect the validity of the remaining
20 provisions of the ordinance.

21 PASSED AND APPROVED by the Mayor and Council of the City of Midwest City, Oklahoma, on the
22 _____ day of _____, 2019.
23

24 THE CITY OF MIDWEST CITY, OKLAHOMA
25

26 _____
27
28 MATTHEW D. DUKES, II, Mayor

29 ATTEST:
30

31 _____
32 SARA HANCOCK, City Clerk
33

34 Approved as to form and legality this _____ day of February, 2019.
35

HEATHER POOLE, City Attorney

1 **ORDINANCE NO.** _____
2

3 **AN ORDINANCE AMENDING THE MIDWEST CITY MUNICIPAL CODE 3041,**
4 **CHAPTER 24, MOTOR VEHICLES, ARTICLE II, ADMINISTRATION AND**
5 **ENFORCEMENT, DIVISION 2, VEHICLE IMPOUNDMENT, SECTION 24-44,**
6 **AUTHORIZED, AND PROVIDING FOR REPEALER AND SERVERABILITY.**
7

8 BE IT ORDAINED BY THE COUNCIL OF THE CITY OF MIDWEST CITY, OKLAHOMA:
9

10 **ORDINANCE**
11

12 SECTION 1. That the Midwest City Municipal Code, Chapter 24, Motor Vehicles, Article II,
13 Administration and Enforcement, Division 2, Vehicle Impoundment, Section 24-44, Authorized,
14 is hereby amended to read as follows:

15
16 Sec. 24-44 Authorized

17 (a) Members of the police department are hereby authorized to remove a vehicle from any
18 street, highway, private property or public property to a storage facility as provided for in
19 section 24-44.1 of this Code under the following circumstances:

20 (1) When any vehicle is left unattended upon any public right-of-way and is so parked
21 as to constitute a hazard or obstruction to the normal movement of traffic or parked
22 where parking is prohibited;

23 (2) When a derelict vehicle has been parked upon public right-of-way for a period of
24 seventy-two (72) hours;

25 (3) When a vehicle has been parked on private property without the consent of the
26 owner or occupant of the property in violation of section 28-56 of this Code;

27 (4) When any vehicle is left abandoned upon public right-of-way in excess of three (3)
28 days from the date it was first reported or observed by officers;

29 (5) When officers recover a vehicle reported stolen and the owner cannot be located, is
30 unable or unwilling to effect the removal of the vehicle within a reasonable amount of
31 time not to exceed one (1) hour, or the preservation and collection of evidence
32 requires removal;

1 (6) Where the vehicle has any evidentiary value, has directly or indirectly been
2 involved in the commission of a crime, has been used to transport any person who has
3 committed any offense involving the use of a firearm, or was directly or indirectly
4 associated with a drive-by shooting;

5 (7) When a police officer effects the arrest of the owner or operator of a vehicle out of
6 said vehicle, and no person immediately present can lawfully or reasonably be given
7 custody of such vehicle;

8 (8) When the vehicle bears a license plate which has expired for a period in excess of
9 ninety (90) days, bears a license plate which has been altered or tampered with, or
10 bears a temporary paper tag which has been altered or expired for a period in excess of
11 ninety (90) days, or bears no license plate which would be in conformance with the
12 Oklahoma Vehicle License Act (47 O.S. § 1101, et seq.);

13 (9) Any place, including place of residence, when a police officer effects the arrest of
14 the operator of the vehicle, out of said vehicle, and the operator is found to have
15 operated the vehicle under any of the following violations: reckless driving, careless
16 driving, driving under the influence of drugs or alcohol, driving while impaired,
17 driving under a suspended, revoked or denied license, driving with no state driver's
18 license, eluding a police officer, duty to give information and render aid, or otherwise
19 involved in a hit-and-run accident, or

20 (10) When the officer has probable cause to believe a vehicle is not insured in
21 compliance with Oklahoma Compulsory Insurance Law, unless the sole basis for the
22 probable cause is the inability to verify insurance through the online verification
23 system.

24
25
26 Section 2. REPEALER. All ordinances or parts of ordinances in conflict herewith are hereby
27 repealed.
28
29
30

1 Section 3. SEVERABILITY. If any section, sentence, clause, or portion of this ordinance is for
2 any reason held to be invalid, such decision shall not affect the validity of the remaining
3 provisions of the ordinance.

4 PASSED AND APPROVED by the Mayor and Council of the City of Midwest City, Oklahoma, on the ____ day of
5 _____, 2019.

THE CITY OF MIDWEST CITY, OKLAHOMA

6
7
8 _____
9 MATTHEW D. DUKES, II, Mayor

10
11
12 ATTEST:

13
14 _____
15 SARA HANCOCK, City Clerk

16
17 Approved as to form and legality this ____ day of February, 2019.

18
19 _____
20 HEATHER POOLE, City Attorney



Public Works Administration
Vaughn Sullivan, Director
vsullivan@midwestcityok.org
R. Paul Streets, Assistant Director
rstreets@midwestcityok.org
8730 S.E. 15th Street,
Midwest City, Oklahoma 73110
O: 405-739-1060 / Fax: 405-739-1090

Memo

To: Honorable Mayor and Council

From: **R. Paul Streets, Assistant Public Works Director**

Date: February 12, 2019

Subject: Discussion and consideration of passing and approving an ordinance amending the Midwest City Municipal Code, Chapter 18, Garbage and Refuse, by amending Article I, in General Section 18-8 Bulk Waste Collection; Article II, Municipal Collection and Disposal Service, Section 18-22(c), City to Furnish Service, Section 18-25(b) and 18-25(f), Container Required, Duty to Use; Section 18-27(a), Residential Service Fees; Special Provisions for Mobile Home Parks; Section 18-28, Business and Commercial Service Fees; Section 18-31, Special Charge for Restoration of Service to Commercial Establishments; and providing for repealer and severability.

The proposed ordinance establishes new sanitation (solid waste) rates for residential, apartment complexes, Mobile Home Park (MHP), and commercial accounts due to a new contract for recycling with Republic Services of Oklahoma City, commercial rate restructuring and a new bulk waste rate. In the preparation of these amended rates, tremendous effort was made to evaluate our current rates, those of other cities in the Oklahoma City metro area and private contracted rates for similar services. Additionally, Midwest City leadership developed a questionnaire and pushed it out to customers the first week of January 2019 to gather feedback. The information received during this process was shared with the Council on January 22nd and as a result, quarterly bulk waste service (Big Trash Day) was added to the ordinance revisions being proposed. Lastly we were asked by appointed and elected leadership, to include an annual rate adjustment based on the Consumer Price Index and any contract obligations, such as curbside recycling. Attached is the rate table for residential customers and the proposed ordinance changes. If you have any questions about the attached documents, please do not hesitate to contact Vaughn Sullivan or myself.

Staff recommends approval.

R. Paul Streets
Assistant Public Works Director

Attached: Residential Solid Waste Rate Sheet
Midwest City Ordinance Excerpt, Chapter 18: "red-lined" and "clean" examples

RESIDENTIAL RATE TABLE

SERVICES	CURRENT	RECOMMENDED RATE
TRASH (96 Gal Cart)	\$11.58	\$11.58
RECYCLING	\$2.87	\$4.21 *
BULK WASTE	NA	\$1.00 **
TOTAL COST	\$14.45	\$16.79
TRASH (65 Gal Cart)	\$9.22	\$9.22
RECYCLING	\$2.87	\$4.21 *
BULK WASTE	NA	\$1.00 **
TOTAL COST	\$12.09	\$14.43
Extra Cart	\$5.50	\$7.00 ***
Mobile Homes	\$14.45	\$16.79

* The new recycling rate reflects the contract price that goes into effect July 1st 2019 plus the 15% administrative fee required by ordinance for any sanitation service provided by a third party.

** This is the rate for the recommended quarterly curbside bulk waste collection that is also commonly called "Big Trash Day".

*** This rate is nearer to our actual cost to provide the service and is consistent with surrounding communities. It will also require a minimum of a one year commitment.

ORDINANCE NO. _____

AN ORDINANCE AMENDING THE MIDWEST CITY MUNICIPAL CODE, CHAPTER 18, GARBAGE AND REFUSE, BY AMENDING ARTICLE I, IN GENERAL SECTION 18-8 BULK WASTE COLLECTION; ARTICLE II, MUNICIPAL COLLECTION AND DISPOSAL SERVICE, SECTION 18-22(C), CITY TO FURNISH SERVICE, Section 18-25(B) AND 18-25(F), Container required, duty to use; Section 18-27(A), Residential service fees; SPECIAL PROVISIONS FOR MOBILE HOME PARKS; SECTION 18-28, BUSINESS AND COMMERCIAL SERVICE FEES; SECTION 18-31, SPECIAL CHARGE FOR RESTORATION OF SERVICE TO COMMERCIAL ESTABLISHMENTS; AND PROVIDING FOR REPEALER AND SEVERABILITY.

BE IT ORDAINED BY THE COUNCIL OF THE CITY OF MIDWEST CITY THAT:

ORDINANCE

SECTION 1. The Midwest City Municipal Code, Chapter 18, Garbage and Refuse, Article I, In General, Section 18-8, is hereby amended to reads as follows:

Sec. 18-8. --Transfer station rules and regulations. Bulk waste collection.

(a) ~~The transfer station may be used only by the residents of the city. It shall be unlawful and an offense for any person or entity that is not a resident of the city to use the transfer station. Patrons of the transfer station are required to present their current Midwest City utility bill and their driver's license showing proof of residence in the city. Residents of the city will be allowed to dump four (4) loads per year (any combination as listed below) at the transfer station at no charge. Any additional loads may be dumped, up to a maximum of ten (10), at the following rates which shall be charged to the resident's utility bill:~~

Pick up load to the top of the cab (open bed)	1 load or \$15.00
Pick up load over the cab (enclosed bed)	2 loads or \$25.00
Trailer, (less than 16 foot) and tow vehicle	3 loads or \$35.00
Trailer (16 foot or longer) and tow vehicle	4 loads or \$50.00
Enclosed trucks, (U Haul, Ryder)	Not allowed

~~(1) Enclosed trucks such as U Haul, Ryder, etc., are not allowed to utilize the transfer station. Such vehicles are considered a safety hazard and will be turned away at the gate.~~

~~(2) Garbage and refuse produced by a resident's household will be accepted at the transfer station including lumber and wood items no more than four (4) feet in length and six (6)~~

~~inches in diameter. Items that will not be accepted at the transfer station include shingles, (both wooden and composite), hazardous wastes, pesticides, herbicides, tires, appliances with compressors, batteries, paints, solvents, motor oil and such other items as the utilities superintendent shall deem detrimental to the transfer station. The city will not be responsible for the negligence of patrons using the transfer station.~~

~~(b) No commercial use of the transfer station is permitted and it shall be unlawful and an offense for any person or entity to use the transfer station for commercial purposes. The determination of an individual utilizing the transfer station in a "commercial manner" is solely at the discretion of the transfer station operator based on their observance of the frequency, and types of debris being brought by the individual.~~

(a) A resident of the city with a current and active utility account for full services, will be provided four bulk collection events annually from the first business day of January to the last business day of December. Excessive amounts of brush, waste, and bulky household items will be collected quarterly at the curbside for the involuntary rate of one dollar per (\$1.00) month.

(b) Bulk waste must be generated by the owner or occupant at that residence to be eligible for collection and must be placed at the curblin for collection or as otherwise designated by the sanitation manager.

(c) Small items must be bagged or boxed. Small items lying loose on the ground will not be picked up by the bulky waste crew. They will be left for the customer to place them in the trash cart for collection.

(d) Tree trimmings and branches must be placed together in piles with individual branches not longer than eight feet. Leaves and small amounts yard waste must be bagged or boxed.

(e) Bulk waste shall be placed neatly and tightly stacked with ten feet of clearance from all obstacles, such as, power poles, mailboxes, signs, fire hydrants, cars and gas meters to allow mechanized pickup.

(f) Bulk waste shall not be placed out for collection earlier than five days preceding the scheduled bulky waste collection day.

(g) By placing bulk waste out for collection, the customer relinquishes title to the bulk item picked up. The division may decline to accept such items as household appliances, contraband, commercial construction debris, or hazardous wastes.

(h) The customer will be charged an additional fee of twenty dollars (\$20.00) for each cubic yard of bulk waste collected in excess of four cubic yards in any single collection event.

SECTION 2. The Midwest City Municipal Code, Chapter 18, Garbage and Refuse, Article II, Municipal Collection and Disposal Service, Section 18-22, is hereby amended to reads as follows:

Sec. 18-22. - City to furnish service.

(a) The city shall collect and dispose of garbage and other refuse as provided in this article.

- (b) Any sanitation services that the city provides through a third party entity will be billed by the city as specified in this article in addition to which there will be charged a fifteen (15) percent administrative fee for this service.
- (c) The city shall increase the sanitation rates annually to begin on May 1st based upon the Consumer Price Index (CPI) published as of March 1st of the same year.

SECTION 3. Municipal Collection and Disposal Service, Section 18-25, is hereby amended to read as follows:

Sec. 18-25. - Container required; duty to use.

- (a) Except as otherwise provided in this article, all residential customers shall place their garbage and refuse in the carts provided by the city and, beginning July 1, 2013, their recyclables in a separate cart provided for that purpose by the city.
- (b) The city shall provide one (1) cart for each residence for garbage and refuse, and one (1) cart for each residence for materials that are to be recycled. Residents are allowed to have additional refuse carts per residence from the city. These carts will be emptied on a weekly basis when the primary cart is emptied with the monthly cost to the resident of the additional carts being ~~five dollars and fifty cents~~ **seven dollars** (~~\$5.50~~) (**\$7.00**) for each additional cart. **Each additional cart requested will require a one year commitment paid in monthly increments unless the customer requests its removal before the end of the year at which point the remaining cost of the commitment will be added to the utility bill.** Residential recycling carts will be emptied bi-weekly.

The resident may place normal household garbage and refuse, as defined in section 18-1 of this Code, in the refuse cart(s) for collection. Residents may place materials they wish to be recycled in the recycling cart. The resident shall be responsible for the safekeeping of the carts until such time as an inspection is made by the city and service is terminated. Should any person change residences, the person shall promptly notify the city. If any cart is lost or stolen, the resident shall promptly notify the police department of the loss or theft of the cart and obtain a case number. Lost or stolen carts will not be replaced without a case number from the police department. The city will empty the carts so long as the carts contain no more than two hundred (200) pounds of garbage and refuse in each cart during any given pickup. If a cart is damaged beyond normal wear and tear, including fire damage from improper disposal of fire ashes, the cost of replacement shall be charged to the resident at the current replacement cost of the cart. All carts shall remain the property of the city even though the resident may have paid for a replacement cart. All carts are to remain at the residence to which they are assigned. It shall be unlawful and an offense for a person to be in possession of a cart without the permission of the resident to which it is assigned. It is the responsibility of the resident to keep the cart clean. At the request of the resident, carts can be cleaned by the city. Such cleaning shall be performed for a twenty dollar (\$20.00) charge which shall be paid by the resident.

- (c) All carts to be emptied, including recycling carts, shall be placed at the curblin. Carts are not to be obstructed from view, e.g., behind parked cars, behind hedges, etc. Carts shall be placed for collection no earlier than 7:00 p.m. the day before the scheduled collection and no later than 7:00 a.m. the day of scheduled collection. The resident is required to return the carts to their regular storage place within five (5) feet of the residential structure or behind the front building line of the property by no later than 7:00 p.m. the day of scheduled

collection. Failure to return the carts by the stated time limitation above may result in a fine not to exceed fifty dollars (\$50.00) to the owner of the residence. A twenty dollar (\$20.00) call back collection fee shall be charged to empty a cart and/or pick up authorized items not at the curblines prior to 7:00 a.m. the day of scheduled collection. Any items that are not in compliance with subsection (d) below that are not picked up during collection shall be removed from the curblines by no later than 7:00 p.m. on the day of scheduled collection. Failure to remove such items not in compliance with subsection (d) by 7:00 p.m. may result in a citation for violation of section 18-6 of this Code.

- (d) Residents may not place with the carts other types of containers for collection. Garbage and refuse placed in refuse carts and recyclable materials placed in recycle carts will be the only things that will be collected during a normal collection.
- (e) Rollout service will be provided for the disabled. Any residence in which all the residents are disabled may request rollout service be performed by the city. The director shall determine the need for rollout service and to approve or disapprove requests. If the director determines that a particular residence qualifies for rollout service, the city will roll out, dump and return the carts at no extra charge.
- (f) There will be a charge of ~~fifteen~~ **twenty-five** dollars (~~\$15.00~~) (**\$25.00**) if a cart is picked up and returned for nonpayment of a sanitation bill.

SECTION 4. Municipal Collection and Disposal Service, Section 18-27, is hereby amended to read as follows:

Sec. 18-27. - Residential service fees; special provisions for mobile home parks.

- (a) Residential service shall consist of the removal of garbage and household refuse which has been placed in either 65-gallon or 95-gallon carts, which size shall be the choice of the resident, in accordance with section 18-25 of this Code. This service is deemed to be necessary to protect the health, safety and welfare of the citizens of the city, and the fees for such service are deemed necessary to pay for the removal of such garbage and household refuse to protect the health of the occupant, owner, tenant or lessee and others in the near vicinity by such removal. The fees for this service shall be as follows:

- (1) Single-family residences, duplexes, single-family garage apartments, and apartment complexes of three units or less: ~~Fourteen dollars and forty five cents~~ **Eleven dollars and fifty eight cents** (~~\$14.45~~) (**\$11.58**) per month for a 95-gallon refuse container or ~~twelve dollars and nine cents~~ **nine dollars and twenty two cents** (~~\$12.09~~) (**\$9.22**) per month for a 65-gallon refuse container. **Residential curbside recycling will be required as a contracted sanitation service provided by a third party with mandatory participation by all residential customers. The rate for this service is four dollars and twenty-one cents (\$4.21) which includes the required 15% administrative fee as referenced in Section 18-22 in this same article. The curbside recycling rate will reflect a mandatory contractual increase of 3% annually beginning May 1st 2020.**

EFFECTIVE DATE:	May 1, 2020	May 1, 2021	May 1, 2022
RATE:	\$4.34	\$4.46	\$4.60

- (2) Apartments complexes in excess of three units: ~~eleven dollars and forty one cents~~ **twelve dollars and eighty two cents** (~~\$11.41~~) (**\$12.82**) per month per apartment, whether

vacant or occupied. For more than two (2) pickups per week, four dollars and twenty-five cents (\$4.25) additional, per apartment per pickup. Dumpsters shall be furnished for apartment complexes on the basis of a one-yard dumpster for each five (5) apartments. Any containers placed at any apartment complex in excess of three apartments that exceeds the calculated number of containers, as outlined above, will be charged at the regular commercial rate in section 18-28 of this Code for the emptying of those additional containers. Apartment complexes in excess of three apartments that utilize a commercial compactor for disposal of their garbage and refuse will be charged as indicated in section 18-22 of this Code.

- (3) Mobile home parks: ~~Fourteen dollars and forty five cents~~ **Eleven dollars and fifty eight cents (\$11.58)** per month per mobile home space, based on the highest number of spaces that are occupied during the month. **Residential curbside recycling will be required as a contracted sanitation service provided by a third party with mandatory participation by all residential customers. The rate for this service is four dollars and twenty-one cents (\$4.21) which includes the required 15% administrative fee as referenced in Section 18-22 in this same article. The curbside recycling rate will reflect a mandatory contractual increase of 3% annually beginning May 1st 2020.**

EFFECTIVE DATE:	May 1, 2020	May 1, 2021	May 1, 2022
RATE:	\$4.34	\$4.46	\$4.60

- (b) In any mobile home park in which the spaces are jointly and commonly metered, the owner of such park shall bear the responsibility of certifying monthly to the city clerk the largest number of mobile homes then located within that park during that month whether connected to service or not. Such certification shall be sworn to before a notary public in such form as the city manager may from time to time prescribe and shall be submitted to the city clerk on the first working day of the month following the month in question. The monthly utility bill for that park shall be computed by multiplying the applicable rates by the largest number of mobile homes within the park during the month in question. In the event the city clerk does not receive the required certification (regardless of the reason for such nonreceipt), then the park shall be conclusively deemed to have been fully occupied for the month in question. It shall be unlawful and an offense to submit a certification to the city setting forth less than the number of mobile homes actually located in a park as of the date and time set forth in the certification. Violation of this section shall, upon conviction, subject the person signing such certification to a fine of one hundred dollars (\$100.00) and, in addition, the park shall be conclusively deemed to have been fully occupied for the month in question.
- (c) The type of collection service provided, either as individual residences or through centralized sanitation containers, shall be determined by the utilities superintendent; provided, however, that should the utilities superintendent approve the placement of centralized sanitation containers in a mobile home park, the following provisions shall apply:
- (1) The charges for sanitation services shall be the same for collection from centralized sanitation containers as previously established for mobile home parks in general.
 - (2) The centralized sanitation container shall be placed on a concrete pad, which must be provided by the park, of no less than six (6) feet in width, eight (8) feet in length and

three (3) inches in thickness. At no time shall the dumpster rest upon or require moving across open ground or other soft surfaces.

- (3) The utilities superintendent shall review the proposed locations of such pads and verify that they are easily and safely accessible for collection prior to their construction.
- (4) At no time shall any items be collected from centralized sanitation containers other than those defined as normal household garbage or refuse. The owner, agent or manager of the mobile home park shall be liable for all damages to a city vehicle caused by inappropriate items concealed in a centralized sanitation container and the owner, agent or manager shall make payment for such damages to the city upon receipt of the statement of damages and costs.
- (5) Should the collector be unable to collect the refuse from a centralized sanitation container because of it containing inappropriate items or because access is blocked, no unscheduled return trip will be made unless the standard special collection fee is paid.

SECTION 5. Municipal Collection and Disposal Service, Section 18-28, is hereby amended to read as follows:

Sec. 18-28. - Business and commercial services fees.

- (a) The minimum charge for commercial sanitation dumpster shall be at the shared rate of a four-yard dumpster serviced ~~twice~~ **once** per ~~month~~-**week** per business, unless the ~~director~~ **superintendent** has allowed the business to be serviced by a residential cart in which case the minimum charge per month shall be twenty-eight dollars and fifty-three cents (\$28.53) without bi-weekly recycling or ~~thirty-one dollars and fifty-four cents~~ **thirty six dollars and fifty-eight cents** (~~\$31.54~~) (**\$36.58**) with bi-weekly recycling. Sharing of dumpsters by businesses will be allowed on a case by case basis, based on space limitation, fire lane location, etc. These must be approved by the director and will be assessed the "shared fee" listed below regardless of how many businesses share the same dumpster.
- (b) Where the city furnishes a four-, six-, or eight-yard dumpster, or a "roll-out" container such as a cart, the following fee schedule shall be charged per month:

Container/Service	Fee	Shared
<i>Cart:</i>		
1-Pickup per week per cart	\$ 28.53	Not allowed
1-Pickup per week w/bi-weekly recycling	31.54 36.58	Not allowed
<i>4-Yard Box:</i>		
1-Pickup per week	\$ 78.84 80.54	\$ 39.42 40.27
	120.34 161.07	60.17 80.54
3-Pickups per week	164.95 241.61	82.47 120.80
4-Pickups per week	209.56 322.15	104.78 161.07
5-Pickups per week	253.13	126.56

6-Pickups per week	303.96	151.98
2-Pickups per month	58.61	29.31
Recycling 1-Pickup per Week	\$52.36	Not allowed
Recycling 2-Pickup per Month	\$31.42	Not allowed
<i>6-Yard Box:</i>		
1-Pickup per week	\$ 97.52 89.54	\$ 48.76 44.77
2-Pickups per week	151.46 187.76	75.73 93.88
3-Pickups per week	203.33 281.64	101.67 140.82
4-Pickups per week	255.20 375.52	127.60 187.76
5-Pickups per week	309.15 469.40	154.57 234.70
6-Pickups per week	371.39	185.70
2-Pickups per month	72.62	36.31
Recycling 1-Pickup per Week	\$78.55	Not allowed
Recycling 2-Pickup per Month	\$47.13	Not allowed
<i>8-Yard Box:</i>		
1-Pickup per week	\$ 117.75 98.19	\$ 58.87 49.10
2-Pickups per week	181.55 196.39	90.77 98.19
3-Pickups per week	254.16 294.58	127.08 147.29
4-Pickups per week	316.41 392.77	158.20 196.39
5-Pickups per week	378.65 490.97	189.33 245.48
6-Pickups per week	451.27 589.16	225.64 294.58
2-Pickups per month	93.37	46.68
Recycling 1-Pickup per Week	\$104.73	Not allowed
Recycling 2-Pickup per Month	\$62.84	Not allowed

- (c) Where additional (special) pickups are requested, a minimum fee of ~~fifty dollars (\$50.00)~~ **the once a week service rate for the size of the container the customer possesses** will be charged per emptied dumpster. The director shall base additional charges on time required to perform the additional (special pickup) and on the basis of manpower and equipment available.
- (d) Commercial accounts that utilize a solid waste compactor serviced by the city front loader vehicles will be charged based on the listed compaction rate for that compactor times the service frequency and size of container.

- (e) Commercial accounts that utilize four (4), six (6), or eight (8) yard trash or recycling containers will be charged fifty dollars (\$50.00) for delivery or removal of the container.

SECTION 6. Municipal Collection and Disposal Service, Section 18-31, is hereby amended to reads as follows:

Sec. 18-31. - Special charge for restoration of service to commercial establishments.

In the event service is discontinued for nonpayment and the dumpster or dumpsters, **whether or not they are shared**, are picked up by the sanitation department, a ~~twenty~~ **fifty** dollar ~~(\$20.00)~~ **(\$50.00)** fee for reinstatement will be paid before said dumpsters are returned.

SECTION 7. REPEALER. All ordinances or parts of ordinances in conflict herewith are hereby repealed.

SECTION 8. SEVERABILITY. If any section, sentence, clause or portion of this ordinance is for any reason held to be invalid, such decision shall not affect the validity of the remaining portions of the ordinance.

PASSED AND APPROVED by the Mayor and Council of the City of Midwest City, Oklahoma, on the ____ day of _____, 2019.

THE CITY OF MIDWEST CITY, OKLAHOMA

MATTHEW D. DUKES, II, Mayor

ATTEST:

SARA HANCOCK, City Clerk

APPROVED as to form and legality this ____ day of _____, 20__.

HEATHER POOLE, City Attorney

ORDINANCE NO. _____

AN ORDINANCE AMENDING THE MIDWEST CITY MUNICIPAL CODE, CHAPTER 18, GARBAGE AND REFUSE, BY AMENDING ARTICLE I, IN GENERAL SECTION 18-8 BULK WASTE COLLECTION; ARTICLE II, MUNICIPAL COLLECTION AND DISPOSAL SERVICE, SECTION 18-22(C), CITY TO FURNISH SERVICE, Section 18-25(B) AND 18-25(F), Container required, duty to use; Section 18-27(A), Residential service fees; SPECIAL PROVISIONS FOR MOBILE HOME PARKS; SECTION 18-28, BUSINESS AND COMMERCIAL SERVICE FEES; SECTION 18-31, SPECIAL CHARGE FOR RESTORATION OF SERVICE TO COMMERCIAL ESTABLISHMENTS; AND PROVIDING FOR REPEALER AND SEVERABILITY.

BE IT ORDAINED BY THE COUNCIL OF THE CITY OF MIDWEST CITY THAT:

ORDINANCE

SECTION 1. The Midwest City Municipal Code, Chapter 18, Garbage and Refuse, Article I, In General, Section 18-8, is hereby amended to reads as follows:

Sec. 18-8. - Bulk waste collection.

- (a) A resident of the city with a current and active utility account for full services, will be provided four bulk collection events annually from the first business day of January to the last business day of December. Excessive amounts of brush, waste, and bulky household items will be collected quarterly at the curbside for the involuntary rate of one dollar per (\$1.00) month.
- (b) Bulk waste must be generated by the owner or occupant at that residence to be eligible for collection and must be placed at the curblineline for collection or as otherwise designated by the sanitation manager.
- (c) Small items must be bagged or boxed. Small items lying loose on the ground will not be picked up by the bulky waste crew. They will be left for the customer to place them in the trash cart for collection.
- (d) Tree trimmings and branches must be placed together in piles with individual branches not longer than eight feet. Leaves and small amounts yard waste must be bagged or boxed.
- (e) Bulk waste shall be placed neatly and tightly stacked with ten feet of clearance from all obstacles, such as, power poles, mailboxes, signs, fire hydrants, cars and gas meters to allow mechanized pickup.
- (f) Bulk waste shall not be placed out for collection earlier than five days preceding the scheduled bulky waste collection day.
- (g) By placing bulk waste out for collection, the customer relinquishes title to the bulk item picked up. The division may decline to accept such items as household appliances, contraband, commercial construction debris, or hazardous wastes.

- (h) The customer will be charged an additional fee of twenty dollars (\$20.00) for each cubic yard of bulk waste collected in excess of four cubic yards in any single collection event.

SECTION 2. The Midwest City Municipal Code, Chapter 18, Garbage and Refuse, Article II, Municipal Collection and Disposal Service, Section 18-22, is hereby amended to reads as follows:

Sec. 18-22. - City to furnish service.

- (a) The city shall collect and dispose of garbage and other refuse as provided in this article.
- (b) Any sanitation services that the city provides through a third party entity will be billed by the city as specified in this article in addition to which there will be charged a fifteen (15) percent administrative fee for this service.
- (c) The city shall increase the sanitation rates annually to begin on May 1st based upon the Consumer Price Index (CPI) published as of March 1st of the same year.

SECTION 3. Municipal Collection and Disposal Service, Section 18-25, is hereby amended to reads as follows:

Sec. 18-25. - Container required; duty to use.

- (a) Except as otherwise provided in this article, all residential customers shall place their garbage and refuse in the carts provided by the city and, beginning July 1, 2013, their recyclables in a separate cart provided for that purpose by the city.
- (b) The city shall provide one (1) cart for each residence for garbage and refuse, and one (1) cart for each residence for materials that are to be recycled. Residents are allowed to have additional refuse carts per residence from the city. These carts will be emptied on a weekly basis when the primary cart is emptied with the monthly cost to the resident of the additional carts being seven dollars (\$7.00) for each additional cart. Each additional cart requested will require a one year commitment paid in monthly increments unless the customer requests its removal before the end of the year at which point the remaining cost of the commitment will be added to the utility bill. Residential recycling carts will be emptied bi-weekly.

The resident may place normal household garbage and refuse, as defined in section 18-1 of this Code, in the refuse cart(s) for collection. Residents may place materials they wish to be recycled in the recycling cart. The resident shall be responsible for the safekeeping of the carts until such time as an inspection is made by the city and service is terminated. Should any person change residences, the person shall promptly notify the city. If any cart is lost or stolen, the resident shall promptly notify the police department of the loss or theft of the cart and obtain a case number. Lost or stolen carts will not be replaced without a case number from the police department. The city will empty the carts so long as the carts contain no more than two hundred (200) pounds of garbage and refuse in each cart during any given pickup. If a cart is damaged beyond normal wear and tear, including fire damage from improper disposal of fire ashes, the cost of replacement shall be charged to the resident at the current replacement cost of the cart. All carts shall remain the property of the city even though the resident may have paid for a

replacement cart. All carts are to remain at the residence to which they are assigned. It shall be unlawful and an offense for a person to be in possession of a cart without the permission of the resident to which it is assigned. It is the responsibility of the resident to keep the cart clean. At the request of the resident, carts can be cleaned by the city. Such cleaning shall be performed for a twenty dollar (\$20.00) charge which shall be paid by the resident.

- (c) All carts to be emptied, including recycling carts, shall be placed at the curb-line. Carts are not to be obstructed from view, e.g., behind parked cars, behind hedges, etc. Carts shall be placed for collection no earlier than 7:00 p.m. the day before the scheduled collection and no later than 7:00 a.m. the day of scheduled collection. The resident is required to return the carts to their regular storage place within five (5) feet of the residential structure or behind the front building line of the property by no later than 7:00 p.m. the day of scheduled collection. Failure to return the carts by the stated time limitation above may result in a fine not to exceed fifty dollars (\$50.00) to the owner of the residence. A twenty dollar (\$20.00) call back collection fee shall be charged to empty a cart and/or pick up authorized items not at the curblines prior to 7:00 a.m. the day of scheduled collection. Any items that are not in compliance with subsection (d) below that are not picked up during collection shall be removed from the curblines by no later than 7:00 p.m. on the day of scheduled collection. Failure to remove such items not in compliance with subsection (d) by 7:00 p.m. may result in a citation for violation of section 18-6 of this Code.
- (d) Residents may not place with the carts other types of containers for collection. Garbage and refuse placed in refuse carts and recyclable materials placed in recycle carts will be the only things that will be collected during a normal collection.
- (e) Rollout service will be provided for the disabled. Any residence in which all the residents are disabled may request rollout service be performed by the city. The director shall determine the need for rollout service and to approve or disapprove requests. If the director determines that a particular residence qualifies for rollout service, the city will roll out, dump and return the carts at no extra charge.
- (f) There will be a charge of twenty-five dollars (\$25.00) if a cart is picked up and returned for nonpayment of a sanitation bill.

SECTION 4. Municipal Collection and Disposal Service, Section 18-27, is hereby amended to read as follows:

Sec. 18-27. - Residential service fees; special provisions for mobile home parks.

- (a) Residential service shall consist of the removal of garbage and household refuse which has been placed in either 65-gallon or 95-gallon carts, which size shall be the choice of the resident, in accordance with section 18-25 of this Code. This service is deemed to be necessary to protect the health, safety and welfare of the citizens of the city, and the fees for such service are deemed necessary to pay for the removal of such garbage and household refuse to protect the health of the occupant, owner, tenant or lessee and others in the near vicinity by such removal. The fees for this service shall be as follows:
 - (1) Single-family residences, duplexes, single-family garage apartments, and apartment complexes of three units or less: Eleven dollars and fifty eight cents (\$11.58) per month for a 95-gallon refuse container or nine dollars and twenty two cents (\$9.22) per month for a 65-gallon refuse container. Residential curbside recycling will be required as a

contracted sanitation service provided by a third party with mandatory participation by all residential customers. The rate for this service is four dollars and twenty-one cents (\$4.21) which includes the required 15% administrative fee as referenced in Section 18-22 in this same article. The curbside recycling rate will reflect a mandatory contractual increase of 3% annually beginning May 1st 2020.

EFFECTIVE DATE:	May 1, 2020	May 1, 2021	May 1, 2022
RATE:	\$4.34	\$4.46	\$4.60

- (2) Apartments complexes in excess of three units: twelve dollars and eighty two cents (\$12.82) per month per apartment, whether vacant or occupied. For more than two (2) pickups per week, four dollars and twenty-five cents (\$4.25) additional, per apartment per pickup. Dumpsters shall be furnished for apartment complexes on the basis of a one-yard dumpster for each five (5) apartments. Any containers placed at any apartment complex in excess of three apartments that exceeds the calculated number of containers, as outlined above, will be charged at the regular commercial rate in section 18-28 of this Code for the emptying of those additional containers. Apartment complexes in excess of three apartments that utilize a commercial compactor for disposal of their garbage and refuse will be charged as indicated in section 18-22 of this Code.
- (3) Mobile home parks: Eleven dollars and fifty cents (\$11.58) per month per mobile home space, based on the highest number of spaces that are occupied during the month. Residential curbside recycling will be required as a contracted sanitation service provided by a third party with mandatory participation by all residential customers. The rate for this service is four dollars and twenty-one cents (\$4.21) which includes the required 15% administrative fee as referenced in Section 18-22 in this same article. The curbside recycling rate will reflect a mandatory contractual increase of 3% annually beginning May 1st 2020.

EFFECTIVE DATE:	May 1, 2020	May 1, 2021	May 1, 2022
RATE:	\$4.34	\$4.46	\$4.60

- (b) In any mobile home park in which the spaces are jointly and commonly metered, the owner of such park shall bear the responsibility of certifying monthly to the city clerk the largest number of mobile homes then located within that park during that month whether connected to service or not. Such certification shall be sworn to before a notary public in such form as the city manager may from time to time prescribe and shall be submitted to the city clerk on the first working day of the month following the month in question. The monthly utility bill for that park shall be computed by multiplying the applicable rates by the largest number of mobile homes within the park during the month in question. In the event the city clerk does not receive the required certification (regardless of the reason for such nonreceipt), then the park shall be conclusively deemed to have been fully occupied for the month in question. It shall be unlawful and an offense to submit a certification to the city setting forth less than the number of mobile homes actually located in a park as of the date and time set forth in the certification. Violation of this section shall, upon conviction, subject the person signing such certification to a fine of one hundred dollars (\$100.00) and, in addition, the park shall be conclusively deemed to have been fully occupied for the month in question.

- (c) The type of collection service provided, either as individual residences or through centralized sanitation containers, shall be determined by the utilities superintendent; provided, however, that should the utilities superintendent approve the placement of centralized sanitation containers in a mobile home park, the following provisions shall apply:
- (1) The charges for sanitation services shall be the same for collection from centralized sanitation containers as previously established for mobile home parks in general.
 - (2) The centralized sanitation container shall be placed on a concrete pad, which must be provided by the park, of no less than six (6) feet in width, eight (8) feet in length and three (3) inches in thickness. At no time shall the dumpster rest upon or require moving across open ground or other soft surfaces.
 - (3) The utilities superintendent shall review the proposed locations of such pads and verify that they are easily and safely accessible for collection prior to their construction.
 - (4) At no time shall any items be collected from centralized sanitation containers other than those defined as normal household garbage or refuse. The owner, agent or manager of the mobile home park shall be liable for all damages to a city vehicle caused by inappropriate items concealed in a centralized sanitation container and the owner, agent or manager shall make payment for such damages to the city upon receipt of the statement of damages and costs.
 - (5) Should the collector be unable to collect the refuse from a centralized sanitation container because of it containing inappropriate items or because access is blocked, no unscheduled return trip will be made unless the standard special collection fee is paid.

SECTION 5. Municipal Collection and Disposal Service, Section 18-28, is hereby amended to reads as follows:

Sec. 18-28. - Business and commercial services fees.

- (a) The minimum charge for commercial sanitation dumpster shall be at the shared rate of a four-yard dumpster serviced once per week per business, unless the superintendent has allowed the business to be serviced by a residential cart in which case the minimum charge per month shall be twenty-eight dollars and fifty-three cents (\$28.53) without bi-weekly recycling or thirty six dollars and fifty-eight cents (\$36.58) with bi-weekly recycling. Sharing of dumpsters by businesses will be allowed on a case by case basis, based on space limitation, fire lane location, etc. These must be approved by the director and will be assessed the "shared fee" listed below regardless of how many businesses share the same dumpster.
- (b) Where the city furnishes a four-, six-, or eight-yard dumpster, or a "roll-out" container such as a cart, the following fee schedule shall be charged per month:

Container/Service	Fee	Shared
<i>Cart:</i>		

1-Pickup per week per cart	\$ 28.53	Not allowed
1-Pickup per week w/bi-weekly recycling	36.58	Not Allowed
<i>4-Yard Box:</i>		
1-Pickup per week	\$ 80.54	\$ 40.27
2-Pickups per week	161.07	80.54
3-Pickups per week	241.61	120.80
4-Pickups per week	322.15	161.07
Recycling 1-Pickup per Week	\$52.36	Not allowed
Recycling 2-Pickup per Month	\$31.42	Not allowed
<i>6-Yard Box:</i>		
1-Pickup per week	\$ 89.54	\$ 44.77
2-Pickups per week	187.76	93.88
3-Pickups per week	281.64	140.82
4-Pickups per week	375.52	187.76
5-Pickups per week	469.40	234.70
Recycling 1-Pickup per Week	\$78.55	Not allowed
Recycling 2-Pickup per Month	\$47.13	Not allowed
<i>8-Yard Box:</i>		
1-Pickup per week	\$ 98.19	\$ 49.10
2-Pickups per week	196.39	98.19
3-Pickups per week	294.58	147.29
4-Pickups per week	392.77	196.39
5-Pickups per week	490.97	245.48
6-Pickups per week	589.16	294.58
Recycling 1-Pickup per Week	\$104.73	Not allowed
Recycling 2-Pickup per Month	\$62.84	Not allowed

(c) Where additional (special) pickups are requested, a minimum fee of the once a week service rate for the size of the container the customer possesses will be charged per

emptied dumpster. The director shall base additional charges on time required to perform the additional (special pickup) and on the basis of manpower and equipment available.

- (d) Commercial accounts that utilize a solid waste compactor serviced by the city front loader vehicles will be charged based on the listed compaction rate for that compactor times the service frequency and size of container.
- (e) Commercial accounts that utilize four (4), six (6), or eight (8) yard trash or recycling containers will be charged fifty dollars (\$50.00) for delivery or removal of the container.

SECTION 6. Municipal Collection and Disposal Service, Section 18-31, is hereby amended to read as follows:

Sec. 18-31. - Special charge for restoration of service to commercial establishments.

In the event service is discontinued for nonpayment and the dumpster or dumpsters, whether or not they are shared, are picked up by the sanitation department, a fifty dollar (\$50.00) fee for reinstatement will be paid before said dumpsters are returned.

SECTION 7. REPEALER. All ordinances or parts of ordinances in conflict herewith are hereby repealed.

SECTION 8. SEVERABILITY. If any section, sentence, clause or portion of this ordinance is for any reason held to be invalid, such decision shall not affect the validity of the remaining portions of the ordinance.

PASSED AND APPROVED by the Mayor and Council of the City of Midwest City, Oklahoma, on the ____ day of _____, 2019.

THE CITY OF MIDWEST CITY, OKLAHOMA

MATTHEW D. DUKES, II, Mayor

ATTEST:

SARA HANCOCK, City Clerk

APPROVED as to form and legality this ____ day of _____, 20__.

HEATHER POOLE, City Attorney



MUNICIPAL AUTHORITY AGENDA

- ♥ The 7:00 PM meetings will be shown live on Channel 20.
- ♥ The recorded video will be available on Youtube and the City's website within 48 hours at www.youtube@midwestcityok.org.
- ♥ The meeting minutes and video can be found on the City's website in the Agenda Center: <https://midwestcityok.org/AgendaCenter>.
- ♥ To make a special assistance request, call 739-1215 or email pmenefee@midwestcityok.org no less than 24 hours prior to the start of a meeting. If special assistance is needed during a meeting, call 739-1388.



MIDWEST CITY MUNICIPAL AUTHORITY AGENDA

City Hall - Midwest City Council Chambers, 100 N. Midwest Boulevard

February 12, 2019 - 6:01 PM

- A. **CALL TO ORDER.**
- B. **CONSENT AGENDA.** These items are placed on the Consent Agenda so that Trustees, by unanimous consent, can approve routine agenda items by one motion. If any item proposed does not meet with approval of all Trustees, or members of the audience wish to discuss an item, it will be removed and heard in regular order.
1. Discussion and consideration of approving the minutes of the regular meeting of January 22, 2019 as submitted. (City Clerk - S. Hancock)
 2. Discussion and consideration of supplemental budget adjustments to the following funds for FY 2018-2019, decrease: Golf Fund, expenses/Golf (47) \$42,842. (Finance - C. Barron)
 3. Discussion and Consideration of entering Into a Contract with Municipal H2O for Professional Services for the MWC Water Treatment Plant for a term of twelve calendar months, for a first year total cost of \$7,200. (Public Works - R. Paul Streets)
- C. **DISCUSSION ITEM.**
1. Consider and vote to approve a resolution authorizing the issuance of not to exceed \$35,000,000 Midwest City Municipal Authority Refunding Revenue Bonds; waiving competitive bidding on said bonds and authorizing the sale of the bonds at a discount; authorizing a supplemental bond indenture, sales tax agreement, bond purchase agreement and such other documents and agreements as may be necessary or required; and containing other provisions relating thereto. (Secretary - S. Hancock)
- D. **NEW BUSINESS/PUBLIC DISCUSSION.** The purpose of the "Public Discussion Section" of the Agenda is for members of the public to speak to the Authority on any Subject not scheduled on the Regular Agenda. The Authority shall make no decision or take any action, except to direct the City Manager to take action, or to schedule the matter for discussion at a later date. Pursuant to the Oklahoma Open Meeting Act, the Authority will not engage in any discussion on the matter until that matter has been placed on an agenda for discussion. **THOSE ADDRESSING THE AUTHORITY ARE REQUESTED TO STATE THEIR NAME AND ADDRESS PRIOR TO SPEAKING TO THE AUTHORITY.**
- E. **ADJOURNMENT.**



CONSENT AGENDA



A notice for the regular Midwest City Municipal Authority was filed for the calendar year with the City Clerk of Midwest City. Public notice of this agenda was accessible at least 24 hours before this meeting at City Hall and on the Midwest City website (www.midwestcityok.org).

Midwest City Municipal Authority Minutes

January 22, 2019 – 6:01 PM

This meeting was held in the Midwest City Council Chamber in City Hall, 100 N. Midwest Boulevard, Midwest City, County of Oklahoma, State of Oklahoma.

Chairman Matt Dukes called the meeting to order at 6:46 PM with the following members present: Trustees Susan Eads, Española Bowen, Sean Reed, and Christine Allen; and Secretary Sara Hancock, City Attorney Heather Poole, and Acting City Manager Tim Lyon. Absent: Pat Byrne and Jeff Moore.

DISCUSSION ITEMS.

- 1. Discussion and consideration of approving the minutes of the regular meeting of January 8, 2019 as submitted.** Eads made a motion to approve the minutes, as submitted, seconded by Allen. Voting aye: Eads, Bowen, Reed, Allen, and Chairman Dukes. Nay: none. Absent: Byrne and Moore. Motion carried.
- 2. Discussion and consideration of accepting the report on the current financial condition of the Sheraton Midwest City Hotel at the Reed Center for the period ending December 31, 2018.** Eads made a motion to accept the report, as submitted, seconded by Reed. Voting aye: Eads, Bowen, Reed, Allen, and Chairman Dukes. Nay: none. Absent: Byrne and Moore. Motion carried.

NEW BUSINESS/PUBLIC DISCUSSION.

There was no new business or public discussion.

ADJOURNMENT.

There being no further business, Chairman Dukes closed the meeting at 6:47 PM.

ATTEST:

MATTHEW D. DUKES II, Chairman

SARA HANCOCK, Secretary



The City of MIDWEST CITY

100 N. MIDWEST BLVD * MIDWEST CITY, OKLAHOMA 73110
(405) 739-1240 * FAX (405) 739-1247 * TDD (405) 739-1359

Memorandum

TO: Honorable Chairman and Trustees
Midwest City Municipal Authority

FROM: Christy Barron, Finance Director

DATE: February 12, 2019

Subject: Discussion and consideration of supplemental budget adjustments to the following funds for FY 2018-2019, decrease: Golf Fund, expenses/Golf (47) \$42,842.

The decrease is needed to reduce budgeted expenses in Golf Fund due to revenue shortfalls in fiscal year 2018-2019.

Christy Barron
Finance Director

DECREASE

February 12, 2019

Fund GOLF (197)		BUDGET AMENDMENT FORM Fiscal Year 2018-2019			
<u>Dept Number</u>	<u>Department Name</u>	<u>Estimated Revenue</u>		<u>Budget Appropriations</u>	
		<u>Increase</u>	<u>Decrease</u>	<u>Increase</u>	<u>Decrease</u>
47	Golf				42,842
		<u>0</u>	<u>0</u>	<u>0</u>	<u>42,842</u>

Explanation:
To reduce budgeted expenses in Golf Fund due to revenue shortfalls in fiscal year 2018-2019.



Public Works Administration
Vaughn Sullivan, Director
vsullivan@midwestcityok.org
R. Paul Streets, Assistant Director
rstreets@midwestcityok.org
8730 S.E. 15th Street,
Midwest City, Oklahoma 73110
O: 405-739-1060 /Fax: 405-739-1090

Memo

To: Honorable Chairman and Trustees
Midwest City Municipal Authority

From: R. Paul Streets, Assistant Public Works Director

Date: February 12, 2019

Subject: Discussion and Consideration of Entering Into a Contract with Municipal H2O for Professional Services for the MWC Water Treatment Plant, for a term of twelve calendar months, for a first year total of \$7,200.

I respectfully request to retain the professional services of Municipal H2O to assist with developing the required elements of our Risk Management Plan (RMP) for the Water Treatment Plant in Midwest City. The RMP covers Chlorine gas safety, its hazards, and any procedures related to a chlorine gas release. Most importantly, it is required by the Environmental Protection Agency (EPA) and errors in the document discovered during an audit could result in penalties or fines. None of the current staff at the Water Plant have received any formal training related to the development or implementation of the RMP which is a very complex document covering a number of risk-laden commitments.

Municipal H2O currently works with four other Municipalities in Oklahoma, including Edmond and Del City, both of which are very satisfied with the professional services they have received. The initial annual cost of this contract is \$7,200.00 which includes the one-time set up cost of \$3,000.00, and thereafter an annual cost of \$4,200.00. These professional services are renewed annually on the anniversary date unless the City opts not to renew. With this contract, if the City is audited by the Oklahoma Department of Environmental Quality (ODEQ) or EPA incurring any fines due to errors or omissions on the part of Municipal H2O's specified Professional Services Agreement (PSA), they will pay the fines.

Funds are budgeted and available to pay for these professional services.

Staff recommends approval.

R. Paul Streets
Assistant Public Works Director

Attached: Professional Services Agreement

PROFESSIONAL SERVICES AGREEMENT

This AGREEMENT is entered into by the City of Midwest City, located in Midwest City, Oklahoma, here-in-after called "CITY" and AssureCo Risk Management and Regulatory Compliance LLC (d/b/a/ MunicipalH2O.com); here-in-after called "MHC". In consideration of the terms and conditions herein, the parties agree as follows:

1. SERVICES TO BE PROVIDED BY MHC. In accordance with the terms of this AGREEMENT, CITY agrees to contract with MHC to perform professional services ("Services") related to CITY compliance with EPA Risk Management Program requirements for the following facility:

Midwest City Water Treatment Plant	10701 Water Plant Road	Midwest City	OK
------------------------------------	------------------------	--------------	----

Services will be performed using online services available at www.MunicipalH2O.com as specified in the attached Exhibit A. MHC shall provide services to CITY as an independent contractor, not as an employee of CITY. All services required hereunder will be performed by MHC or under its supervision.

2. MHC COMPLIANCE GUARANTEE. MHC agrees to pay any and all fines imposed by the Environmental Protection Agency (EPA), or in OSHA-delegated states the responsible state agency, levied on CITY because of CITY's failure to comply with EPA's Risk Management Program rule ("RMP") or the state's equivalent of RMP, provided that the fine is for a failure to comply during the term of MHC's Services, following MHC's completion of the Services specified as part of the Compliance Set-up Services in Exhibit A, and provided that CITY has fully complied with CITY's Compliance Guarantee Requirements specified in Exhibit B. CITY agrees to promptly notify MHC in the event that a fine, otherwise covered by this guaranty, is proposed or levied and further agrees to provide MHC with a copy of the written citation and allow MHC to communicate with EPA or the state agency, in conjunction with CITY, to attempt to negotiate a reduction in the amount of said fine or otherwise mitigate the amount thereof, should MHC, in its sole discretion, choose to do so. Notwithstanding the above provisions, this guaranty shall exclude any fine levied for a violation resulting from any error or omission of CITY: (a) to maintain equipment, and properly document such maintenance, covered by RMP requirements (e.g. such as hoists and chlorine detectors) according to procedures specified by the manufacturer in the owner's manual, and (b) to provide in a timely manner operator

procedures training for new operators and refresher training for existing operators and properly document such training as required by RMP. MHC agrees that it is responsible for including such RMP requirements in the written Prevention Program provided to CITY by MHC. This guaranty shall also exclude any fine levied more than one (1) year after the termination of this Agreement for any reason by either party.

3. COMPENSATION. CITY agrees to pay MHC a one-time Setup Fee of **\$3,000**. Additionally, CITY agrees to pay MHC a monthly fee of **\$350** for a first-year total cost of **\$7,200** (Setup Fee plus 12 months of monthly fees) for the professional services specified in Exhibit A during the term of this AGREEMENT. Payments are due within thirty (30) days of CITY's receipt of invoice. If services beyond the professional services described in Exhibit A are required by CITY, the time and cost required to perform such services shall be agreed upon by CITY and MHC prior to the initiation of such work. The parties agree that the professional services specified in Exhibit A, with the exception of MHC's presence during an EPA or state inspection, normally can be performed by telephone and through the online services of MunicipalH2O.com. If any of the professional services require a site visit, including during an EPA or state inspection, and if CITY approves the site visit in advance, CITY agrees to reimburse MHC for travel expenses to include mileage expense calculated using current IRS rates (or airfare and rental car if less expensive) and lodging and meals if required to complete the work.

4. COOPERATION. CITY agrees to provide such cooperation and support as reasonably necessary to allow MHC to timely and efficiently complete the required services.

5. TERM AND TERMINATION. The AGREEMENT is effective on the date of signature by CITY and MHC, for a Term of twelve (12) calendar months, during which time the AGREEMENT may only be terminated in the event of a material breach of the Agreement, which the defaulting party fails to cure within ten (10) business days of written notice. The AGREEMENT will automatically renew each year at the Monthly Service Fee quoted for an additional one-year term on the anniversary of the effective date unless written notice is provided to the other party by the party wishing to terminate at least thirty (30) days prior to the renewal date.

6. CONFIDENTIALITY. The parties to this AGREEMENT agree that neither they nor their employees, agents and assigns shall disclose any information pertaining to the business affairs, finances, methods of operation, computer programs or any personal information of the other, whether written, oral, or otherwise, except where required by law or upon express consent of the other party.

7. NOTICES. Any notices required pursuant to this AGREEMENT shall be mailed to the parties at the following addresses:

AssureCo Risk Management and Regulatory Compliance LLC (MHC):

ARMARC/MunicipalH2O
Attention: MHC Business Operations
650 South Shackelford Rd, Suite 325
Little Rock, AR 72211

City of Midwest City (CITY):

City of Midwest City
Attention: Water Plant Chief Operator
100 North Midwest Boulevard
Midwest City, OK 73110

8. MISCELLANEOUS. Nothing under this AGREEMENT shall be construed to give any rights or benefits in this AGREEMENT to anyone other than CITY and MHC, and all duties and responsibilities undertaken pursuant to this AGREEMENT will be for the sole and exclusive benefit of CITY and MHC and not for the benefit of any other party. If any provision of this AGREEMENT is found or deemed by a court of competent jurisdiction to be invalid or unenforceable, it shall be considered severable from the remainder of this AGREEMENT and shall not cause the remainder to be invalid or unenforceable. In such event, the parties shall reform this AGREEMENT to replace such stricken provision with a valid and enforceable provision which comes as close as legally possible to expressing the intention of the stricken provision. This AGREEMENT is governed by the laws of the State of Oklahoma and any legal action brought shall be brought in Midwest City and Oklahoma County, Oklahoma.

This AGREEMENT, together with Exhibit A and Exhibit B attached hereto, constitutes the entire AGREEMENT between CITY and MHC and supersedes all prior written or oral understandings. This AGREEMENT is executed in two counterparts.

IN TESTIMONY HEREOF, the duly authorized representatives of the parties have executed this AGREEMENT as shown below:

City of Midwest City (CITY):

Print Name

Date

Signature

Title

AssureCo Risk Management and Regulatory Compliance LLC (MHC)

Print Name

Date

Signature

Title

EXHIBIT A
Scope of Services

In accordance with the terms of the AGREEMENT, MHC will provide the following professional services:

Compliance Set-up Services for the Facility:

1. Conduct an EPA Compliance Audit
2. Based on information provided by CITY, create and/or update RMP written documentation, including:
 - Compliance Audit Report
 - Hazard Assessment using EPA's RMP*Comp software and the latest available US Census software available from the MARPLOT mapping program.
 - RMP Prevention Program with all elements as required by EPA
 - Hazard Review or Process Hazard Analysis
3. Complete EPA registration forms and electronic filing using EPA's RMP*eSubmit as required.
4. Set up MunicipalH2O web-based account allowing CITY to receive the RMP Compliance Alert Service.
5. Provide training to CITY on the use of online RMP tools and resources available through the MunicipalH2O web-based service.

Ongoing Compliance Maintenance Services for the Facility:

1. Maintain and update as needed the CITY MunicipalH2O.com web site to reflect any changes that occur in the facility or operations of CITY by maintaining regular contact with CITY to inquire about facility or process changes that may have affected RMP compliance requirements;
2. Assist in the conduct and documentation of the recurring requirements of the RMP standards, as needed, to include:
 - Written Prevention Program updates
 - Compliance Audits and reports
 - Hazard Review/Analysis updates and reports
 - Operating Procedures updates and training materials
 - Written Hazard Assessment updates
 - EPA Registration updates and submittals
3. Conduct, in cooperation with CITY, an annual RMP Compliance Review of the facility and process covered by this Agreement to ensure ongoing compliance and update documentation as needed. Annual Compliance Review shall be conducted by telephone or web-conference using the online automation tools of MunicipalH2O;
4. Provide onsite support upon request in conjunction with an EPA or state inspection related to RMP, provided that at least five (5) business days' prior written notice (email, fax, postal mail or courier) is provided to MHC; and
5. Provide the Compliance Guarantee to pay any fines resulting from MunicipalH2O's errors or omissions as specified in this Agreement.

EXHIBIT B
Compliance Guarantee Requirements

In accordance with the terms of Section 2 of the AGREEMENT, CITY understands and agrees that the MHC Compliance Guarantee is invalidated and becomes immediately null and void if CITY does not consistently and promptly perform the following requirements (“Compliance Guarantee Requirements”):

1. In response to MHC’s email and/or telephone request, provide MHC with timely and accurate information regarding all changes in CITY facility treatment processes, personnel, equipment used, operating procedures, equipment maintenance procedures, quantities of chemicals used, and other matters relevant to EPA or State Risk Management Program Requirements. It shall be CITY’s responsibility to return MHC’s telephone call based on MHC leaving one voicemail message at CITY’s telephone number of record and sending one email to CITY’s email address of record;
2. Promptly implement and adequately document the performance of the recurring requirements specified in the written Prevention Program provided by MHC to CITY, including proper equipment maintenance in accordance with manufacturer’s specifications and proper training of new facility operators and service suppliers (“Recurring Requirements”);
3. Promptly implement and adequately document the performance of all actions specified as needed for EPA and State Risk Management Program compliance in MHC Compliance Alerts made available on CITY’s MHC website home page accessible at www.MunicipalH2O.com and/or provided to CITY in a written communication from MHC delivered by U.S. Postal service mail, overnight courier, email or Facsimile (“Required Actions”);
4. Promptly reply to any MHC telephone call when a voicemail is left by MHC at CITY telephone number of record indicating the call is regarding CITY “RMP Compliance Update” and promptly reply to any email from MHC entitled “RMP Compliance Update” sent to CITY email address of record.; and
5. Ensure that MHC is always provided with current information regarding CITY designated compliance contact person, an alternate contact person in the event that the primary contact person is not available, and the telephone number(s), email address(es) and Facsimile number(s) appropriate for compliance-related communications.
6. Promptly notify MHC of receipt of any communication from EPA, OSHA or a state agency regarding CITY’s non-compliance with RMP requirements covered under this Agreement; and grant MHC permission to communicate directly with EPA, OSHA or state agency making such allegation of non-compliance in an effort to avoid a citation or mitigate the amount of fine related to the alleged non-compliance.



DISCUSSION ITEM





Memorandum

TO: Honorable Chairman and Trustees

FROM: Sara Hancock, Secretary

DATE: February 12, 2019

SUBJECT: Consider and vote to approve a resolution authorizing the issuance of not to exceed \$35,000,000 Midwest City Municipal Authority Refunding Revenue Bonds; waiving competitive bidding on said bonds and authorizing the sale of the bonds at a discount; authorizing a supplemental bond indenture, sales tax agreement, bond purchase agreement and such other documents and agreements as may be necessary or required; and containing other provisions relating thereto.

Action is necessary to start the transaction refunding the outstanding Series 2011 bonds issued in connection with the Reed Conference Center and Sheraton.

Staff recommends approval.

Sara Hancock
Sara Hancock, Secretary

THE TRUSTEES OF THE MIDWEST CITY MUNICIPAL AUTHORITY MET IN REGULAR SESSION AT 100 NORTH MIDWEST BOULEVARD, IN THE COUNCIL CHAMBERS, CITY HALL, IN THE CITY OF MIDWEST CITY, OKLAHOMA, ON THE 12TH DAY OF FEBRUARY 2019, AT 6:00 O'CLOCK P.M.

PRESENT:

ABSENT:

Written notice of the schedule of regular meetings for the Authority for calendar year 2019 having been given to the City Clerk of Midwest City, Oklahoma prior to December 15, 2018, and the agenda for this meeting having been posted in prominent view at the City Hall, 100 North Midwest Boulevard, Midwest City, Oklahoma, twenty-four (24) hours prior to this meeting, excluding Saturdays, Sunday and legal holidays, all in compliance with the Oklahoma Open Meeting Act.

(OTHER PROCEEDINGS)

THEREUPON, a Resolution No. MA 2019-____ was considered. Upon motion of _____, seconded by _____, the Resolution was passed and adopted with the following vote:

AYE:

NAY:

The Resolution was thereupon signed by the Chairman of Trustees of the Authority and attested and sealed with the seal of the Authority by the Secretary of Trust and is as follows:

RESOLUTION NO. MA 2019- ____

A RESOLUTION AUTHORIZING THE ISSUANCE OF NOT TO EXCEED \$35,000,000 MIDWEST CITY MUNICIPAL AUTHORITY REFUNDING REVENUE BONDS; DESIGNATING THE UNDERWRITER, BOND COUNSEL AND FINANCIAL ADVISOR; WAIVING COMPETITIVE BIDDING ON SAID BONDS AND AUTHORIZING THE SALE OF THE BONDS AT A DISCOUNT; AUTHORIZING A SUPPLEMENTAL BOND INDENTURE, A BOND PURCHASE AGREEMENT, SALES TAX AGREEMENT AND SUCH OTHER DOCUMENTS AND AGREEMENTS AS MAY BE NECESSARY OR REQUIRED; AND CONTAINING OTHER PROVISIONS RELATING THERETO.

WHEREAS, the Midwest City Municipal Authority (the "Authority") was created by a Trust Indenture dated as of July 23, 1968, as amended (the "Trust Indenture"), for the use and benefit of the City of Midwest City, Oklahoma (the "City"), under authority of and pursuant to the provisions of Title 60, Oklahoma Statutes, Section 176 to 180.3, inclusive, as amended and supplemented, and other applicable statues of the State of Oklahoma; and

WHEREAS, the Authority has heretofore issued its Midwest City Municipal Authority Capital Improvement Refunding Revenue Bonds, Series 2011, in the original principal amount of \$26,630,000 (the "2011 Bonds"); and

WHEREAS, the Authority has determined to refund the 2011 Bonds through the issuance of its revenue bonds (the "2019 Bonds") in order to achieve interest cost and other savings and to construct, equip, furnish, and install capital improvements to the approximately 150 room hotel and related facilities adjacent to the Reed Center in the City of Midwest City, Oklahoma (the "Project"); and

WHEREAS, there has been presented to this meeting a form of the Series 2019 Supplemental Bond Indenture by and between the Authority and BOKF, National Association, as Trustee (the "Trustee"); and

WHEREAS, there has been presented to this meeting a form of Sales Tax Agreement (the "Sales Tax Agreement"), between the Authority and the City relating to the 2019 Bonds; and

WHEREAS, the Authority has determined in connection with the issuance and sale of the 2019 Bonds that Wells Nelson & Associates, LLC be designated as underwriter (the "Underwriter"), Hilborne & Weidman, a professional corporation, be appointed as Bond Counsel (the "Bond Counsel"), and The Baker Group, LP be appointed as Financial Advisor (the "Financial Advisor"), and that competitive bidding be waived for purposes of approving and contracting for the negotiated sale of the 2019 Bonds; and

WHEREAS, the Underwriter has offered to purchase the 2019 Bonds and the Authority has determined to sell the 2019 Bonds to the Underwriter under the terms and conditions hereinafter set forth and pursuant to the terms of the form of Bond Purchase Agreement

presented to this meeting by and between the Authority and the Underwriter (the “Purchase Agreement”); and

BE IT RESOLVED BY THE TRUSTEES OF THE MIDWEST CITY MUNICIPAL AUTHORITY:

Section 1. The incurring of indebtedness by the Trustees of Authority in order to refinance the Prior Bonds and to fund the Project in the aggregate principal amount of not to exceed \$35,000,000, to be evidenced by and pursuant to the terms of the Bonds is hereby approved. The Underwriter, Financial Advisor and Bond Counsel and the staff of the Authority are hereby authorized and directed to prepare all documents and instruments necessary or convenient for the sale, issuance and delivery of the 2019 Bonds.

Section 2. The forms of Indenture, Sales Tax Agreement, and Purchase Agreement presented with this resolution be, and hereby are, approved, and the Chairman or Vice Chairman of Trustees and the Secretary or any Assistant Secretary of the Authority be, and they hereby are, authorized, directed and empowered to execute and deliver in the name of the Authority the Indenture, Sales Tax Agreement, and Purchase Agreement.

Section 3. The Chairman or Vice Chairman of Trustees and the Secretary or any Assistant Secretary of Trustees of the Authority be, and they hereby are, authorized, directed and empowered to execute and deliver in the name of the Authority the Indenture, Sales Tax Agreement, Purchase Agreement and other documents, agreements, closing papers and certificates in such forms and containing substantially the terms and provisions as shall be approved by the officers executing such documents and agreements, the execution thereof by such officers being conclusive evidence of such approval, and to execute and deliver in the name and on behalf of the Authority all documents, closing papers, certificates and such other documents as are necessary to accomplish the issuance and sale of the 2019 Bonds.

Section 4. The signatures of the officers of the Authority appearing on the Indenture, Sales Tax Agreement, Purchase Agreement and the agreements, documents, closing papers and certificates executed and delivered pursuant to this resolution shall be conclusive evidence of their approval thereof and of their authority to execute and deliver such agreements and documents on behalf of the Authority.

Section 5. The Chairman or Vice Chairman of Trustees and the Secretary or any Assistant Secretary of the Authority be, and they hereby are, authorized and empowered for and on behalf of the Authority, to execute and deliver such further agreements and documents and to take such action as such officer or officers may deem necessary or desirable in order to carry out and perform the Indenture, Sales Tax Agreement, Purchase Agreement and any contracts, documents, or instruments executed and delivered in connection with the issuance of the 2019 Bonds, and to effect the purposes thereof and to consummate the transactions contemplated thereby.

Section 6. It is hereby determined to be necessary and in the best interest of the trust estate that the 2019 Bonds be issued and the issuance thereof in the aggregate principal amount of not to exceed \$35,000,000, the specific principal amount thereof to be determined by the Chairman or Vice Chairman of the Authority and set forth in a written certificate of determination prior to the issuance of the 2019 Bonds is hereby authorized and approved. It is further hereby determined to be necessary and in the best interest of the trust estate that the aforesaid offer of the Underwriter be accepted and that the 2019 Bonds be issued and sold to it at a price equal to not less than ninety-nine percent (99.0%) of the principal amount thereof, the purchaser and the specific purchase price to be determined by the Chairman or Vice Chairman of the Authority and set forth in a written Certificate of Determination at or before the issuance of the 2019 Bonds, and competitive bidding is hereby specifically waived with respect to the sale of the 2019 Bonds and the sale of the 2019 Bonds for a purchase price determined as aforesaid, which purchase price may constitute an underwriter's discount of not to exceed one percent (1.0%) of the principal amount of the 2019 Bonds is hereby specifically approved. The Chairman or Vice Chairman of the Authority is hereby authorized, empowered and directed to determine and establish the interest rate or rates on the 2019 Bonds, which shall not exceed an average interest rate of four and one-quarter percent (4.25%) per annum, and to establish the maturity dates of the 2019 Bonds, which maturities of the 2019 Bonds shall not exceed thirty (30) years and to set forth such interest rate or rates and maturities in a Certificate of Determination at or prior to the issuance of the 2019 Bonds.

ADOPTED the 12th day of February, 2019.

ATTEST:

Chairman

Secretary

(SEAL)

I, the undersigned, the duly qualified and acting Secretary of the Midwest City Municipal Authority, hereby certify that the foregoing is a true, correct and complete copy of a Resolution of the Trustees of the Authority held on the date therein stated as the same appears in the minutes of said meeting on file in my office as a part of the official records thereof. I hereby certify that attached hereto as Exhibit "A" is a true and complete copy of the schedule of regular meetings for the Authority for calendar year 2019 which was given to the City Clerk of Midwest City, Oklahoma prior to December 15, 2018, and that attached hereto as Exhibit "B" is a true and correct copy of the Agenda posted in prominent public view at 100 North Midwest Boulevard, Midwest City, Oklahoma, twenty-four (24) hours prior to the date of the meeting therein described, excluding Saturdays, Sundays and legal holidays.

WITNESS my hand and seal of said Authority this 12th day of February, 2019.

(SEAL)

Secretary



NEW BUSINESS/
PUBLIC DISCUSSION





MEMORIAL HOSPITAL AUTHORITY AGENDA

- ♥ 6:00 PM meetings will be shown live on Channel 20.
- ♥ The recorded video will be available on Youtube and the City's website within 48 hours at www.youtube@midwestcityok.org.
- ♥ The meeting minutes and video can be found on the City's website in the Agenda Center: <https://midwestcityok.org/AgendaCenter>.
- ♥ To make a special assistance request, call 739-1215 or email pmenefee@midwestcityok.org no less than 24 hours prior to the start of a meeting. If special assistance is needed during a meeting, call 739-1388.



MIDWEST CITY MEMORIAL HOSPITAL AUTHORITY AGENDA

City Hall - Midwest City Council Chambers, 100 N. Midwest Boulevard

February 12, 2019 - 6:02 PM

- A. CALL TO ORDER.
- B. CONSENT AGENDA. These items are placed on the Consent Agenda so that the Trustees, by unanimous consent, can approve routine agenda items by one motion. If any item proposed does not meet with approval of all Trustees, or members of the audience wish to discuss an item, it will be removed and heard in regular order.
1. Discussion and consideration of approving the minutes of the regular meeting of January 22, 2019, as submitted. (City Clerk - S. Hancock)
 2. Discussion and consideration of supplemental budget adjustments to the following fund for FY 2018-2019, increase: Hospital Authority Fund, expenses/Hospital Authority (90) \$81,309. (Finance – C. Barron)
 3. Discussion and consideration of approving an engagement letter with Grant Thornton, LLP to perform a GAAP audit for the calendar year ending December 31, 2018 for STC II, LLC in an amount not to exceed \$27,200 for audit fees plus 7% for administrative fees of \$1,904 and authorizing the city manager to act on behalf of the Authority during the audit to provide information, oversee the audit process and make determinations as required.
- C. DISCUSSION ITEM.
1. Discussion and consideration of action to reallocate assets, change fund managers or make changes in the Statement of Investment Policy, Guidelines and Objectives. (Secretary - S. Hancock)
- D. NEW BUSINESS/PUBLIC DISCUSSION. The purpose of the "Public Discussion Section" of the Agenda is for members of the public to speak to the Authority on any Subject not scheduled on the Regular Agenda. The Authority shall make no decision or take any action, except to direct the City Manager to take action, or to schedule the matter for discussion at a later date. Pursuant to the Oklahoma Open Meeting Act, the Authority will not engage in any discussion on the matter until that matter has been placed on an agenda for discussion. **THOSE ADDRESSING THE AUTHORITY ARE REQUESTED TO STATE THEIR NAME AND ADDRESS PRIOR TO SPEAKING TO THE AUTHORITY.**
- E. EXECUTIVE SESSIONS.
1. Discussion and consideration of 1) entering into executive session, as allowed under 25 O.S. § 307(B)(3), to discuss the purchase or appraisal of real property; and 2) in open session, authorizing the general manager/administrator to take action as appropriate based on the discussion in executive session. (Economic Development - R. Coleman)

2. Discussion and consideration of 1) entering into executive session, as allowed under 25 O.S. § 307(C)(10), to confer on matters pertaining to economic development, including the transfer of property, financing or the creation of a proposal to entice a business to remain or to locate within the City; and 2) in open session, authorizing the city manager to take action as appropriate based on the discussion in executive session. (Economic Development - R. Coleman)

FURTHER INFORMATION.

1. Discussion and consideration of 1) taking action on the following recommendations hereby made by the Trust Board of Grantors from the qualified FY 2018-19 grant applications:
 - Refill Mid-Del (Mid-Del School Foundation) for **\$36,395.20**;
 - Septic System Replacement (Mid-Del Youth and Family Center, Inc.) for **\$10,000**;
 - Freezers for Mobile Meals (St. Matthew United Methodist Church, Inc.) for **\$20,000**;
 - Refrigerators for Mobile Meals (St. Matthew United Methodist Church, Inc.) for **\$9,100**;
 - MCHS Band Instruments (MWC High School) for **\$23,400**;
 - Blue Light Phones for Rail with Trail (MWC Parks & Rec) for **\$15,000**;
 - MWC Soccer Club Marquees (MWC Soccer Club) for **\$44,013.80**;
 - Original Mile Homebuyer Assistance Program (MWC Grant Mgmt.) for **\$50,000**;
 - Leah's Hope Transitional Housing Program (Leah's Hope, Inc.) for **\$37,960**;
 - Park a Lot (Kiwanis Club of MWC) for **\$25,000**;
 - Community Connection Marque (Willow Brook Elementary) for **\$25,000**;
 - Middle Income Housing Rehab Loan Program (MWC Grant Mgmt.) for **\$50,000**;
 - Trailer Mounted Impact Attenuator (MWC PWA) for **\$19,182.00**;
 - Business Compliance Grant Program (MWC E.D.) for **\$50,000** to be used for "Underground Storage Tank Removal" and "Abandoned, Dilapidated or Obsolete Structures," with any leftover funds may be used for "Decorative Lighting";
 - Lion's Park Electronic Message Board Relocation (MWC Parks & Rec.) for **\$40,000** to be consistent with color and design of other City signs;
 - Rescue Boat (MWC Fire) for **\$3,449**;
 - Community Improvement Grant Program Branding (MWC Comm.) for **\$3,500**;
 - Electronic Marquee for Public Works (MWC PWA) for **\$38,000** to be consistent with color and design of other City signs;
- and 2) authorizing distribution of the funds hereby approved for the FY 2018-19 in an amount not to exceed \$500,000; and 3) to further recommend and approve such modifications of the Grant Recipient Agreement as recommended by legal counsel. (City Manager - T. Lyon)

G. ADJOURNMENT.



CONSENT AGENDA



A notice for the regular Midwest City Memorial Hospital Authority was filed for the calendar year with the City Clerk of Midwest City. Public notice of this agenda was accessible at least 24 hours before this meeting at City Hall and on the Midwest City website (www.midwestcityok.org).

Midwest City Memorial Hospital Authority Minutes

January 22, 2019 – 6:02 pm

This meeting was held in the Midwest City Council Chambers at City Hall, 100 North Midwest Boulevard, Midwest City, County of Oklahoma, State of Oklahoma. Chairman Matt Dukes called the meeting to order at 6:47 PM with the following members present: Trustees: Susan Eads, Española Bowen, Sean Reed, and Christine Allen; and Secretary Sara Hancock, City Attorney Heather Poole, and Acting City Manager Tim Lyon. Absent: Pat Byrne and Jeff Moore.

CONSENT AGENDA. Eads made a motion to approve the consent agenda, as submitted, seconded by Bowen. Voting aye: Eads, Bowen, Reed, Allen, and Chairman Dukes. Nay: none. Absent: Byrne and Moore. Motion carried.

1. Discussion and consideration of approving the minutes of the regular meeting of January 8, 2019, as submitted.
2. Discussion and consideration of supplemental budget adjustments to the following fund for FY 2018-2019, increase: Sooner Rose TIF Fund, expenses/Hospital Authority (90) \$24,000.

DISCUSSION ITEM.

1. **Discussion and consideration of action to reallocate assets, change fund managers or make changes in the Statement of Investment Policy, Guidelines and Objectives.** No action needed.

NEW BUSINESS/PUBLIC DISCUSSION. There was no new business or public discussion.

EXECUTIVE SESSION.

1. **Discussion and consideration of 1) entering into executive session, as allowed under 25 O.S. § 307(B)(3), to discuss the purchase or appraisal of real property; and 2) in open session, authorizing the general manager/administrator to take action as appropriate based on the discussion in executive session.** No executive session was needed.

ADJOURNMENT.

There being no further business, Chairman Dukes adjourned the meeting at 6:48 PM.

ATTEST:

MATTHEW D. DUKES II, Chairman

SARA HANCOCK, Secretary



Midwest City Memorial Hospital Authority

100 North Midwest Boulevard
Midwest City, Oklahoma 73110
(405) 739-1207 Fax (405) 739-1208 TDD (405) 739-1359
E-mail: ghenson@midwestcityok.org

MEMORANDUM

TO: Honorable Chairman and Trustees

FROM: Christy Barron, Treasurer/Finance Director

DATE: February 12, 2019

SUBJECT: Discussion and consideration of supplemental budget adjustments to the following fund for FY 2018-2019, increase: Hospital Authority Fund, expenses/Hospital Authority (90) \$81,309.

The supplement is needed to budget expense to Enerfin Resources per the Development Financing Assistance Agreement for Sooner Rose Phase 3.

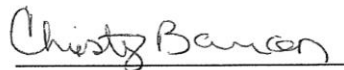

Christy Barron
Finance Director

SUPPLEMENTS

February 12, 2019

Fund HOSPITAL AUTHORITY (425)		BUDGET AMENDMENT FORM Fiscal Year 2018-2019			
		Estimated Revenue		Budget Appropriations	
<u>Dept Number</u>	<u>Department Name</u>	<u>Increase</u>	<u>Decrease</u>	<u>Increase</u>	<u>Decrease</u>
90	Hospital Authority			81,309	
		<u>0</u>	<u>0</u>	<u>81,309</u>	<u>0</u>

Explanation:
 To budget expense to Enerfin Resources per the Development Financing Assistance Agreement for Sooner Rose Ph 3.
 Funding to come from fund balance.



City Manager
100 N. Midwest Boulevard
Midwest City, OK 73110
office 405.739.1204

MEMORANDUM

TO: Midwest City Hospital Authority

FROM: Tim Lyon, Acting City Manager

DATE: February 12, 2019

SUBJECT: Discussion and consideration of approving an engagement letter with Grant Thornton, LLP to perform a GAAP audit for the calendar year ending December 31, 2018 for STC II, LLC in an amount not to exceed \$27,200 for audit fees plus 7% for administrative fees of \$1,904 and authorizing the city manager to act on behalf of the Authority during the audit to provide information, oversee the audit process and make determinations as required.

Attached for your review and approval is an agreement with Grant Thornton, LLP, Charlotte, NC, to provide the required audit for property associated with STC II (Dicks, Office Depot and McAllister's).

The cost of the audit is borne by the LLC. Approval of the engagement letter allows the Authority to be a participant in the audit process and allows the Authority to review audit working papers and related documents.

Staff recommends approval.

Tim Lyon
Acting City Manager



January 7, 2019

Mr. Robert C. Collett
Managing Member
Sooner Town Center II, LLC
1111 Metropolitan Avenue, #700
Charlotte, NC 28204

Grant Thornton LLP
201 S. College Street
Suite 2500
Charlotte, NC 28244

T 704.632.3500
F 704.334.7701
www.GrantThornton.com

Katherine Fox
Chief Financial Officer
Sooner Town Center II, LLC
1111 Metropolitan Avenue, #700
Charlotte, NC 28204

Mr. Matthew Dukes II
Chairman
Midwest City Hospital Authority
100 N Midwest City Blvd
Midwest City, OK 73110

Dear Mr. Collett and Mr. Dukes:

Thank you for discussing with us the requirements of our forthcoming engagement. This letter (the "Engagement Letter") documents our mutual understanding of the arrangements for the services described herein.

Scope of services

Grant Thornton LLP ("Grant Thornton") will audit the balance sheet of Sooner Town Center II, LLC, as of December 31, 2018, and the related statements of operations, members' deficit and cash flows for the year then ended.

Our audit will be conducted in accordance with auditing standards generally accepted in the United States of America ("US GAAS") established by the American Institute of Certified Public Accountants ("AICPA"). An audit involves performing procedures to obtain audit evidence about the amounts and disclosures in the financial statements. The procedures selected depend on the auditor's judgment, including the assessment of the risks of material misstatement of the financial statements, whether due to fraud or error. An audit also includes evaluating the appropriateness of accounting policies used and the reasonableness of significant accounting estimates made by management, as well as evaluating the overall financial statement presentation.

In assessing the risks of material misstatement, an auditor considers internal control relevant to the company's preparation and fair presentation of the financial statements in order to design audit procedures that are appropriate in the circumstances. An audit is not designed to identify control deficiencies or for the purpose of expressing an opinion on internal control; accordingly, we will not express such an opinion. However, we are responsible for communicating to you (hereinafter referred to as "those charged with governance") significant deficiencies and material weaknesses in internal control that come to our attention during the course of our engagement.

When conducting an audit, the auditor is required to obtain reasonable assurance about whether the financial statements are free from material misstatement, whether caused by error or fraud, to enable the auditor to express an opinion on whether the financial statements are presented fairly, in all material respects, in accordance with accounting principles generally accepted in the United States of America. Although not absolute assurance, reasonable assurance is, nevertheless, a high level of assurance. However, an audit is not a guarantee of the accuracy of the financial statements. Even though the audit is properly planned and performed in accordance with professional standards, an unavoidable risk exists that some material misstatements may not be detected due to the inherent limitations of an audit, together with the inherent limitations of internal control. Also, an audit is not designed to detect errors or fraud that is immaterial to the financial statements.

Upon the completion of the foregoing audit and subject to its findings, we will render our report and communicate our findings in accordance with US GAAS. However, it is possible that circumstances may arise in which our report may differ from its expected form and content, resulting in a modified report or disclaimer of opinion. Further, if in our professional judgment the circumstances necessitate, we may resign from the engagement prior to completion.

Our audit does not relieve management or those charged with governance of their responsibilities.

Responsibilities of those charged with governance

Effective two-way communication with those charged with governance assists us in obtaining information relevant to the audit and also assists those charged with governance in fulfilling their responsibility to oversee the financial reporting process. Those charged with governance play an important role in the Company's internal control over financial reporting by setting a positive tone at the top and challenging the Company's activities in the financial arena. Accordingly, it is important for those charged with governance to communicate to us matters they believe are relevant to our engagement. As indicated below, management also has a responsibility to communicate certain matters to those charged with governance and to Grant Thornton.

In connection with our engagement, professional standards require us to communicate certain matters that come to our attention to those charged with governance, such as the following:

- fraud involving senior management and fraud that causes a material misstatement
- illegal acts, unless clearly inconsequential
- disagreements with management and other serious difficulties encountered
- qualitative aspects of significant accounting practices, including accounting policies, estimates, and disclosures
- audit adjustments and uncorrected misstatements, including missing disclosures.

Management responsibilities

As you are aware, the financial statements are the responsibility of management. Management is responsible for preparing and fairly presenting the financial statements in accordance with accounting principles generally accepted in the United States of America, which includes adopting sound accounting practices and complying with changes in accounting principles and related guidance. Management is also responsible for:

- providing us with access to all information of which they are aware that is relevant to the preparation and fair presentation of the financial statements, including all financial records, documentation of internal control and related information, and any additional information that we may request for audit purposes
- providing us with unrestricted access to persons within the Company from whom we determine it necessary to obtain audit evidence
- ensuring that the Company identifies and complies with all laws, regulations, contracts, and grants applicable to its activities and for informing us of any known violations
- designing, implementing, and maintaining internal control to enable the preparation and fair presentation of financial statements that are free of material misstatement, whether due to error or fraud, and for informing us of all known significant deficiencies and material weaknesses in, and significant changes in, such internal control
- informing us of their views about the risk of fraud within the Company and their awareness of any known or suspected fraud and the related corrective action proposed
- adjusting the financial statements, including disclosures, to correct material misstatements and for affirming to us in a representation letter that the effects of any uncorrected misstatements, including missing disclosures, aggregated by us during the current engagement, including those pertaining to the latest period presented, are immaterial, both individually and in the aggregate, to the financial statements as a whole
- informing us of any events occurring subsequent to the balance sheet date through the date of our auditor's report that may affect the financial statements or the related disclosures
- informing us of any subsequent discovery of facts that may have existed at the date of our auditor's report that may have affected the financial statements or the related disclosures.

To assist those charged with governance in fulfilling their responsibility to oversee the financial reporting process, management should discuss with those charged with governance the:

- adequacy of internal control and the identification of any significant deficiencies or material weaknesses, including the related corrective action proposed
- significant accounting policies, alternative treatments, and the reasons for the initial selection of, or change in, significant accounting policies
- process used by management in formulating particularly sensitive accounting judgments and estimates and whether the possibility exists that future events affecting these estimates may differ markedly from current judgments
- basis used by management in determining that uncorrected misstatements, including missing disclosures, are immaterial, both individually and in the aggregate, including whether any of these uncorrected misstatements could potentially cause future financial statements to be materially misstated.

We will require management's cooperation to complete our services. In addition, we will obtain, in accordance with professional standards, certain written representations from management, which we will rely upon.

Use of our report(s)

The inclusion, publication, or reproduction by the Company of our report(s) in documents such as private placement memoranda and regulatory filings containing information in addition to financial statements may require us to perform additional procedures to fulfill our professional or legal responsibilities. Accordingly, our report(s) should not be used for any such purposes without our prior permission. To avoid unnecessary delay or misunderstanding, it is important that the Company give us timely notice of its intention to issue any such document.

Other services

Supplementary information

Management is responsible for separately preparing the balance sheet and statement of operations, and other supplementary schedules including net operating income, debt service, net cash flow, and subtenant rents in accordance with SAS 119, *Supplementary Information in Relation to the Financial Statements as a Whole* (the "applicable criteria"). The supplementary schedules of net operating income, debt service, net cash flow, and subtenant rents will be prepared in compliance with the terms defined in the governing lease agreements with Midwest City, Oklahoma (the "Agreement"). Such supplementary information, which will be presented for purposes of additional analysis and is not a required part of the financial statements, will be subjected to the auditing procedures applied in the audit of the financial statements and certain additional procedures. These procedures will include comparing and reconciling the supplementary information directly to the underlying accounting and other records used to prepare the financial statements or to the financial statements themselves, and other additional

procedures in accordance with US GAAS. The purpose of our procedures will be to form and express an opinion as to whether the supplementary information is fairly stated, in all material respects, in relation to the financial statements as a whole.

In connection with our procedures, management is responsible for informing us about:

- the methods of measurement and presentation of the supplementary information
- whether those methods have changed from the methods used in the prior period and the reasons for the change, if any
- any significant assumptions or interpretations underlying the measurement or presentation of the supplementary information.

Management will present the supplementary information with the audited financial statements. Management is responsible for including our report on the supplementary information in any document that contains the supplementary information and that indicates we reported on it.

We will require management to provide us with certain written representations related to their responsibilities described above, including whether management believes the supplementary information (including its form and content) is fairly presented in accordance with the applicable criteria.

Related non-audit services

We will also perform certain bookkeeping services for the Company. The objective of such services will be to draft the Company's financial statements based on information in the trial balance and other information to be provided to us that is approved by you.

As mentioned previously, the financial statements, including the data and information set forth therein, are the responsibility of management. With respect to our bookkeeping services, however, management is also responsible for:

- making all management decisions and performing all management functions
- designating an individual who possesses suitable skills, knowledge, or experience, preferably within senior management, to oversee the services
- evaluating the adequacy and the results of the services performed
- accepting responsibility for the results of the services.

Accordingly, our bookkeeping services will not include management functions or making management decisions. However, we may provide advice, research materials, and recommendations to assist you in performing your responsibilities.

Other services

Any other services that you request will constitute a separate engagement that will be subject to our acceptance procedures.

Fees

Standard billings

Our billings for the services set forth in this Engagement Letter, which we have estimated will total \$27,200 and are payable within 20 days of receipt.

In addition, we will bill for our expenses, including an administrative charge of seven percent of fees to cover items such as copies, postage, supplies, computer and technology usage, software licensing, research and library databases, and similar expense items.

If it appears that the estimated fee will be exceeded, we will bring this to your attention.

From time to time, Grant Thornton may receive certain incentives in the form of bonuses and rewards from its corporate card and other vendors. Such incentives to the extent received will be retained by Grant Thornton to cover firm expenses.

Additional billings

Of course, circumstances may arise that will require us to do more work. Some of the more common circumstances include changing auditing, accounting, and reporting requirements from professional and regulatory bodies; incorrect accounting applications or errors in Company records; restatements; failure to furnish accurate and complete information to us on a timely basis; and unforeseen events, including legal and regulatory changes.

At Grant Thornton, we pride ourselves on our ability to provide outstanding service and meet our clients' deadlines. To help accomplish this goal, we work hard to have the right professionals available. This involves complex scheduling models to balance the needs of our clients and the utilization of our people, particularly during peak periods of the year. Last minute client requested scheduling changes result in costly downtime due to our inability to make alternate arrangements for our professional staff.

We will coordinate a convenient time for Grant Thornton to begin work. If, after scheduling our work, you do not provide proper notice, which we consider to be one week, of your inability to meet the agreed-upon date(s) for any reason, or do not provide us with sufficient information required to complete the work in a timely manner, additional billings will be rendered for any downtime of our professional staff.

Adoption of new revenue and leasing standards

ASC 606, *Revenue from Contracts with Customers*, is effective for non-public business entities for annual reporting periods beginning after December 15, 2018. ASC 842, *Leases*, is effective for non-public business entities for annual reporting periods beginning after December 15, 2019.

We will communicate with management and those charged with governance periodically to understand the Company's ASC 606 or ASC 842 adoption and implementation plan and the progress in executing that implementation plan. As the Company executes on its

implementation plan and identifies necessary changes to systems, processes, and policies, we will request meetings and review documentation related to those expected changes.

Any work we perform related to your ASC 606 or ASC 842 implementation is not included in the scope of work for the audit services outlined in this Engagement Letter. We will discuss with you the fees for the ASC 606 or ASC 842 implementation work. Those fees will be at higher rates than those utilized in the standard audit rates discussed above.

Adoption of other new accounting standards

Professional and regulatory bodies frequently issue new accounting standards and guidance. Sometimes, standards are issued and become effective in the same period, providing a limited implementation phase and preventing us from including the impact in our estimated fees. In such circumstances, we will discuss with you the additional audit procedures and related fees, including matters such as the retrospective application of accounting changes and changes in classification.

Other costs

Except with respect to a dispute or litigation between Grant Thornton and the Company, our costs and time spent in legal and regulatory matters or proceedings arising from our engagement, such as subpoenas, testimony, or consultation involving private litigation, arbitration, industry, or government regulatory inquiries, whether made at the Company's request or by subpoena, will be billed to the Company separately.

Professional standards impose additional responsibilities regarding the reporting of illegal acts that have or may have occurred. To fulfill our responsibilities, we may need to consult with Company counsel or counsel of our choosing about any illegal acts that we become aware of. Additional fees, including legal fees, will be billed to the Company. The Company agrees to ensure full cooperation with any procedures that we may deem necessary to perform.

Right to terminate services for nonpayment

In the event of nonpayment, we retain the right to (a) suspend the performance of our services, (b) change the payment conditions under this Engagement Letter, or (c) terminate our services. If we elect to suspend our services, such services will not be resumed until your account is paid as agreed. Alternatively, if we elect to terminate our services for nonpayment, the Company will be obligated to compensate us for all time expended and to reimburse us for all expenses through the date of termination.

Other matters

Relationship to Grant Thornton International Ltd

Grant Thornton is the U.S. member firm of Grant Thornton International Ltd ("GTIL"), an organization of independently owned and managed accounting and consulting firms.

References to GTIL are to Grant Thornton International Ltd. GTIL and the member firms are not a worldwide partnership. Services are delivered independently by the member firms. These firms are not members of one international partnership or otherwise legal partners with each

other internationally, nor is any one firm responsible for the services or activities of any other firm.

Use of third-party service providers and affiliates

Grant Thornton may use third-party service providers, such as independent contractors, specialists, or vendors, to assist in providing our professional services. We may also use GTIL member firms, other affiliates (including the GT US Shared Services Center India Private Limited and the Grant Thornton US Knowledge and Capability Center India Private Limited, affiliates of Grant Thornton located in Bangalore, India), or other accounting firms. Such entities may be located within or outside the United States.

Grant Thornton intends to use the professional services, technology, and resources of the following entity to assist us in the performance of the engagement:

- Capital Confirmation, Inc. – electronic confirmation services
214 Centerview Drive, Suite 265
Brentwood, TN 37027
888-716-3577

Additionally, Grant Thornton may use third-party service providers to provide administrative or operational support to Grant Thornton, or to provide engagement team resource services. Such entities may be located within or outside the United States. All of these third party service providers are subject to confidentiality obligations to protect the confidentiality of client data.

You hereby consent and authorize us to disclose Company information to the GT US Shared Services Center India Private Limited and/or the Grant Thornton US Knowledge and Capability Center India Private Limited and the other above named entity for purposes of providing services to you as part of our professional relationship.

Privacy

Grant Thornton is committed to protecting personal information and will maintain such information in confidence in accordance with professional standards and governing laws. The Company will not provide any personal information to Grant Thornton unless necessary to perform the services described herein. When providing any personal information to us, the Company will comply with all applicable laws (both foreign and domestic) and will anonymize, mask, obfuscate, and/or de-identify, if reasonably possible, all personal information that is not necessary to perform the services described herein. Any personal information provided to us by the Company will be kept confidential and not disclosed to any third party unless expressly permitted by the Company or required by law, regulation, legal process, or professional standards. The Company is responsible for obtaining, pursuant to law or regulation, consents from parties that provided the Company with their personal information, which will be obtained, used, and disclosed by Grant Thornton for its required purposes.

Documentation

The documentation for this engagement is the property of Grant Thornton and constitutes confidential information. We have a responsibility to retain the documentation for a period of time sufficient to satisfy any applicable legal or regulatory requirements for records retention.

Pursuant to law or regulation, we may be requested to make certain documentation available to regulators, governmental agencies, or their representatives (“Regulators”). If requested, access to the documentation will be provided to the Regulators under our supervision. We may also provide copies of selected documentation, which the Regulators may distribute to other governmental agencies or third parties. You hereby acknowledge we will allow and authorize us to allow the Regulators access to, and copies of, the documentation in this manner.

Electronic communications

During the course of our engagement, we may need to electronically transmit confidential information to each other and to third-party service providers or other entities engaged by either Grant Thornton or the Company. Electronic methods include telephones, cell phones, e-mail, secure file transfers, use of SharePoint sites, and fax. These technologies provide a fast and convenient way to communicate. However, all forms of electronic communication have inherent security weaknesses, and the risk of compromised confidentiality cannot be eliminated. The Company agrees to the use of electronic methods to transmit and receive information, including confidential information.

Standards of performance

We will perform our services in conformity with the terms expressly set forth in this Engagement Letter, including all applicable professional standards. Accordingly, our services shall be evaluated solely on our substantial conformance with such terms and standards. Any claim of nonconformance must be clearly and convincingly shown.

With respect to the services and this Engagement Letter, in no event shall the liability of Grant Thornton and its present, future, and former partners, principals, directors, employees, agents, and contractors for any claim, including but not limited to Grant Thornton’s own negligence, exceed the fees it receives for the portion of the work giving rise to such liability. This limitation shall not apply to the extent that it is finally determined that any claims, losses, or damages are the result of Grant Thornton’s gross negligence or willful misconduct. In addition, Grant Thornton shall not be liable for any special, consequential, incidental, or exemplary damages or loss (nor any lost profits, interest, taxes, penalties, loss of savings, or lost business opportunity) even if Grant Thornton was advised in advance of such potential damages. This paragraph and the paragraph directly below shall apply to any type of claim asserted, including contract, statute, tort, or strict liability, whether by the Company, Grant Thornton, or others.

Further, the Company shall, upon receipt of written notice, indemnify and hold harmless Grant Thornton and its present, future, and former partners, principals, directors, employees, agents, and contractors from and against any liability and damages (including punitive damages), fees, expenses, losses, demands, and costs (including defense costs) associated with any claim arising from or relating to the Company’s knowing misrepresentations or false or incomplete

information provided to Grant Thornton. In the event of any controversy or claim against Grant Thornton arising from or related to the services described herein, Grant Thornton shall be entitled to defend itself from such controversy or claim and to participate in any settlement, administrative, or judicial proceedings.

It is expressly agreed by the Company and Grant Thornton that any claim by, or on behalf of either party, arising out of services or this Engagement Letter, whether it be in contract, tort, or otherwise, shall be deemed waived if a claim is asserted more than two (2) years from: (i) the date of the report(s) issued by Grant Thornton; or (ii) the date of this Engagement Letter if no report has been issued.

If because of a change in the Company's status or due to any other reason, any provision in this Engagement Letter would be prohibited by laws, regulations, or published interpretations by governmental bodies, commissions, state boards of accountancy, or other regulatory agencies, such provision shall, to that extent, be of no further force and effect, and the Engagement Letter shall consist of the remaining portions.

Dispute resolution

Any controversy or claim arising out of or relating to the services, related fees, or this Engagement Letter shall first be submitted to mediation. A mediator will be selected by agreement of the parties, or if the parties cannot agree, a mediator acceptable to all parties will be appointed by the American Arbitration Association ("AAA"). The mediation will proceed in accordance with the customary practice of mediation. In the unlikely event that any dispute or claim cannot be resolved by mediation, we both recognize that the matter will probably involve complex business or accounting issues that would be decided most equitably to us both by a judge hearing the evidence without a jury. Accordingly, to the extent now or hereafter permitted by applicable law, the Company and Grant Thornton agree to waive any right to a trial by jury in any action, proceeding, or counterclaim arising out of or relating to our services or this Engagement Letter.

If the above jury trial waiver is determined to be prohibited by applicable law, then the parties agree that the dispute or claim shall be settled by binding arbitration. The arbitration proceeding shall take place in the city in which the Grant Thornton office providing the relevant services is located, unless the parties mutually agree to a different location. The proceeding shall be governed by the provisions of the Federal Arbitration Act ("FAA") and will proceed in accordance with the then current Arbitration Rules for Professional Accounting and Related Disputes of the AAA, except that pre-hearing discovery must be specifically authorized by the arbitrator. The arbitrator will be selected from AAA, JAMS, the Center for Public Resources, or any other internationally or nationally-recognized organization mutually agreed upon by the parties. Potential arbitrator names will be exchanged within 15 days of the parties' agreement to settle the dispute or claim by binding arbitration, and arbitration will thereafter proceed expeditiously. The arbitration will be conducted before a single arbitrator, experienced in accounting and auditing matters. The arbitrator shall have no authority to award non-monetary or equitable relief and will not have the right to award punitive damages. The award of the arbitration shall be in writing and shall be accompanied by a well-reasoned opinion. The

award issued by the arbitrator may be confirmed in a judgment by any federal or state court of competent jurisdiction. Each party shall be responsible for their own costs associated with the arbitration, except that the costs of the arbitrator shall be equally divided by the parties. The arbitration proceeding and all information disclosed during the arbitration shall be maintained as confidential, except as may be required for disclosure to professional or regulatory bodies or in a related confidential arbitration. In no event shall a demand for arbitration be made after the date when institution of legal or equitable proceedings based on such claim would be barred under the applicable statute of limitations.

Authorization

This Engagement Letter sets forth the entire understanding between the Company and Grant Thornton regarding the services described herein and supersedes any previous proposals, correspondence, and understandings, whether written or oral. If any portion of this Engagement Letter is held invalid, it is agreed that such invalidity shall not affect any of the remaining portions.

Please confirm your acceptance of this Engagement Letter by signing below and returning one copy to us in the enclosed self-addressed envelope.

Sincerely,

GRANT THORNTON LLP



Lauren M. Spegal
Partner

Agreed and accepted by:

SOONER TOWN CENTER II, LLC



Robert C. Collett, Managing Member

Date: 1/22/19



Katherine Fox, Chief Financial Officer of Collett
As an agent of Sooner Town Center II, LLC

Date: 1/23/19

MIDWEST CITY HOSPITAL
AUTHORITY

Date: _____

Matthew Dukes II, CHAIRMAN

ATTEST:

Sara Hancock, City Clerk

Approved as to form and legality this ____ day of
February, 2019

Heather Poole, City Attorney



DISCUSSION ITEM





Midwest City Memorial Hospital Authority
100 North Midwest Boulevard
Midwest City, Oklahoma 73110
Office (405) 739-1207/Fax (405) 739-1208
www.midwestcityok.org

MEMORANDUM

To: Honorable Chairman and Trustees

From: Sara Hancock, Secretary

Date: February 12, 2019

Subject: Discussion and consideration of action to reallocate assets, change fund managers or make changes in the Statement of Investment Policy, Guidelines and Objectives.

Jim Garrels, President, Fiduciary Capital Advisors, asked staff to put this item on each agenda in the event the Hospital Authority's investments need to be reallocated, an investment fund manager needs to be changed or changes need to be made to the Statement of Investment Policy on short notice.

Action is at the discretion of the Authority.

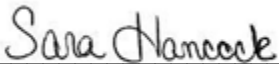
Sara Hancock, Secretary



NEW BUSINESS/
PUBLIC DISCUSSION





EXECUTIVE SESSION





Economic Development
100 N. Midwest Blvd.
Midwest City, OK 73110
rcoleman@midwestcityok.org
Office: 405-739-1218
www.midwestcityok.org

MEMORANDUM

TO: Honorable Chairman and Trustees

FROM: Robert Coleman, Economic Development Director

DATE: February 12, 2019

SUBJECT: Discussion and consideration of 1) entering into executive session, as allowed under 25 O.S. § 307(B)(3), to discuss the purchase or appraisal of real property; and 2) in open session, authorizing the general manager/ administrator to take action as appropriate based on the discussion in executive session.

Appropriate information will be dispersed during executive session.

Robert Coleman, Economic Development Director



Midwest City Memorial Hospital Authority
100 North Midwest Boulevard
Midwest City, Oklahoma 73110
Office (405) 739-1207/Fax (405) 739-1208
www.midwestcityok.org

MEMORANDUM

To: Honorable Chairman and Trustees

From: Robert Coleman, Economic Development Director

Date: February 12, 2019

Subject: Discussion and consideration of 1) entering into executive session, as allowed under 25 O.S. § 307(C)(10), to confer on matters pertaining to economic development, including the transfer of property, financing or the creation of a proposal to entice a business to remain or to locate within the City; and 2) in open session, authorizing the city manager to take action as appropriate based on the discussion in executive session.

Appropriate information will be provided in executive session.

Robert Coleman, Economic Development Director



FURTHER INFORMATION





Acting City Manager
100 N. Midwest Boulevard
Midwest City, OK 73110
tlyon@midwestcityok.org
Office: 405.739.1201
www.midwestcityok.org

MEMORANDUM

To: Honorable Chairman and Trustees of the Memorial Hospital Authority

From: Tim Lyon, Acting City Manager

Date: February 12, 2019

Subject: Discussion and consideration of 1) taking action on the following recommendations hereby made by the Trust Board of Grantors from the qualified FY 2018-19 grant applications:

- Refill Mid-Del (Mid-Del School Foundation) for \$36,395.20;
- Septic System Replacement (Mid-Del Youth and Family Center, Inc.) for \$10,000;
- Freezers for Mobile Meals (St. Matthew United Methodist Church, Inc.) for \$20,000;
- Refrigerators for Mobile Meals (St. Matthew United Methodist Church, Inc.) for \$9,100;
- MCHS Band Instruments (MWC High School) for \$23,400;
- Blue Light Phones for Rail with Trail (MWC Parks & Rec) for \$15,000;
- MWC Soccer Club Marquees (MWC Soccer Club) for \$44,013.80;
- Original Mile Homebuyer Assistance Program (MWC Grant Mgmt.) for \$50,000;
- Leah's Hope Transitional Housing Program (Leah's Hope, Inc.) for \$37,960;
- Park a Lot (Kiwanis Club of MWC) for \$25,000;
- Community Connection Marque (Willow Brook Elementary) for \$25,000;
- Middle Income Housing Rehab Loan Program (MWC Grant Mgmt.) for \$50,000;
- Trailer Mounted Impact Attenuator (MWC PWA) for \$19,182.00;
- Business Compliance Grant Program (MWC E.D.) for \$50,000 to be used for "Underground Storage Tank Removal" and "Abandoned, Dilapidated or Obsolete Structures," with any leftover funds may be used for "Decorative Lighting";
- Lion's Park Electronic Message Board Relocation (MWC Parks & Rec.) for \$40,000 to be consistent with color and design of other City signs;
- Rescue Boat (MWC Fire) for \$3,449;
- Community Improvement Grant Program Branding (MWC Comm.) for \$3,500;
- Electronic Marquee for Public Works (MWC PWA) for \$38,000 to be consistent with color and design of other City signs;

and 2) authorizing distribution of the funds hereby approved for the FY 2018-19 in an amount not to exceed \$500,000; and 3) to further recommend and approve such modifications of the Grant Recipient Agreement as recommended by legal counsel.

The Trust Board of Grantors (the Board) met on January 24, 2019 to consider funding for the grant applications submitted for the FY 2018-19 grant year with a funding allocation total of \$500,000.

The Authority received twenty-five eligible grant applications totaling \$1,152,679.08 in requests. The Board is recommending that the above mentioned eighteen grants totaling \$500,000 be funded in FY 018-19. Last year, the Authority funded 26 grants for a total of \$450,000.

Attached you will find a spreadsheet of the twenty-five eligible 2018-19 grant applications with the comments and rankings. Also attached is the previously approved FY 2018-19 Grant Recipient Agreement along with the suggested modifications from our legal counsel. The last spreadsheet is the previous year's awarded grants. Copies of the FY 2018-19 full grant applications are available in the City Manager's office or via Dropbox at your request.

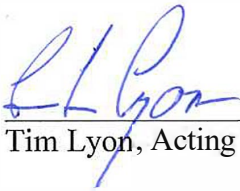

Tim Lyon, Acting City Manager

Grant #	Applicant	Grant Title	Amount Requested	#1 Score	#1 Note	#1 Rec. Funding	#2 Score	#2 Note	#2 Rec. Funding	#3 Score	#3 Note	#3 Rec. Funding	#4 Score	#4 Note	#4 Rec. Funding	#5 Score	#5 Note	#5 Rec. Funding
12	Mid-Del school foundation	fill Mid-Del	\$3 ,395.78	A	Abstain Member of the Mid-Del school Board		100	reat dea	\$3 ,000.00	100	ood pro ect, long-lasting benefits.	3 395.78	95	Partial.	\$25,000.00	A	Abstain usband is a member of the Mid-Del school Board	
20	Mid-Del outh and amily Center, nc.	ptic ystem	\$10,000.00	100		\$10,000.00	95	These ids suffer enough-give them some plumbing help.	\$10,000.00	100	Definitely how grants should be used to help community.	\$10,000.00	100	Absolutely	\$10,000.00	70	Can the City manage the pro ect payout reimbursement for wor done versus cash up front elect small group benefited.	\$10,000.00
3	t. Matthew nited Methodist Church, nc.	Mobile Meals at t. Matthew	\$20,000.00	88	With conditions.	\$20,000.00	100	reat program-great submission	\$20,000.00	80		\$20,000.00	90		\$20,000.00	90	Benefit to large segment population. Proven record. Would approve \$20,000. Potential to purchase fewer with delivery pie from egiional ood Ban fire uency increase. eturn to City if discontinued.	\$20,000.00
	t. Matthew nited Methodist Church, nc.	Mobile Meals at t. Matthew	\$9,100.00	90	With conditions.	\$9,100.00	100	reat program-great submission for the community	\$9,100.00	75		\$9,100.00	90		\$9,100.00	90	eturn to City if discontinued. \$9100.	\$9,100.00
13	MWC igh school Band	MC Band	\$23, 00.00	A	Abstain Member of the Mid-Del school Board		93	reat dea	\$23,000.00	100	chools should be supported students shouldnt have to share instruments.	\$23, 00.00	95		\$23, 00.00	A	Abstain usband is a member of the Mid-Del school Board	\$18, 19.00
32	MWC Par s ec.	Blue ight Phones for ail with Trail	\$15,000.00	75		\$15,000.00	5	Only -how about the other trails	\$15,000.00	100	Whatever we can do to help citizens feel safe, we should.	\$15,000.00	90	Partial funding.	\$7,500.00	90	afety to general public.	\$15,000.00
8	MWC ocker Club	MWC ocker Club Mar uees	\$,013.80	85		\$,013.80	35	is a lot of money-do they do any fundraisers onors ; 3 mprovement overall for community.	\$,000.00	100	Partial funding.	\$,013.80	90		\$25,000.00	90	s there a local company with comparable product to avoid shipping Multiple benefited, improves aesthetics of City, purpose defined outcome.	\$,013.80
23	MWC rant Mgmt.	Original Mile omebuyer Assistance Program	\$50,000.00	95		\$50,000.00	9	thin the income level for 1 in household is very high for a grant.	\$50,000.00	100	At lst glance, may not thin benefits community at large, big picture, it will.	\$50,000.00	85	alf funding.	\$25,000.00	98		\$50,000.00
10	eah s ope, nc.	eah s ope Transitional ousing Program	\$ 8,9 0.00	70	Partial funding no furniture.	\$35,000.00	5	ow many homeless in MWC ; 3 ood Pro ect.	\$ 8,000.00	80		\$ 8,9 0.00	95	ent.	\$37,000.00	73	uggest re ure rab coverage for rents. Would agree to 2 apts. for test. Other programs available for same purpose, MCA.	\$ 8,9 0.00
18	MWC Com. Dev.	Trail Counters	\$1 ,000.00	9		\$1 ,000.00	33	Wouldnt this be covered under the sales ta increases	\$1 ,000.00	100		\$1 ,000.00	80	alf funding.	\$8,000.00	33	Benefit to whom Measure of success. City budget available.	\$1 ,000.00
17	iwanis Club of MWC	Par a ot	\$25,000.00	87		\$25,000.00	15	We have all of these sales ta increases-why doesnt t this cover it	\$25,000.00	100	reatly needed.	\$25,000.00	95		\$25,000.00	70	Benefit to those who use pavilion and nearby neighborhood. Par access may be improved. Aesthetic appeal.	\$25,000.00
15	Willow Broo Elementary	Community Connection Mar ue	\$25,000.00	3		\$25,000.00	8		\$25,000.00	100		\$25,000.00	90		\$25,000.00	0	Allow sign similar to soccer fields - \$15,000 O CP pay for installation. mprove Aesthetic appearance of MWC treet and area.	\$15,000.00
2	MWC rant Mgmt.	Middle ncome ousing ehav oan Program	\$50,000.00	93		\$50,000.00	20	omebuyer for Orig. Mile this-income levels DO OT MATC -please reevaluate submit again.	\$50,000.00	100		\$50,000.00	85	alf funding.	\$25,000.00	100		\$50,000.00
30	MWC PWA	Trailer Mounted mpact Attenuator	\$20,000.00	97		\$20,000.00	5	ow many city employees wor on streets at one time	\$20,000.00	100	All the reasons stated ma e it viable.	\$20,000.00	95		\$20,000.00	0	City budget 20 year life Benefit to public at large.	\$20,000.00
22	ose tate College	Accelerating Manufacturing O Pilot Program	\$50,000.00	73		\$25,000.00	0	Who else have they partnered with Private Corp or the A	\$50,000.00	85		\$50,000.00	A	Abstain Part-time employee		8	ife of cabots - does it e ceed 20 years with tech development trends imited impact to small segment. ose tate budget funds.	\$50,000.00
21	MWC Economic Development	Business Compliance rant Program	\$100,000.00	9		\$100,000.00	1	100 is a lot of money for private business grants-	\$100,000.00	100	Entire community will benefit.	\$100,000.00	95	alf funding.	\$50,000.00	50	Can this be for blight removal only with no sidewal or wal ability allowance with focus to clean up the City City budget available for sidewal s, lights in Town Center.	\$100,000.00
29	MWC Par s ec.	ions Par Electronic Message Board elocation	\$ 0,000.00	87		\$ 0,000.00	8	ow many electronic signs does MWC need Does anyone read the one 29th Air Depot Will the City employ a full time electronic sign manager	\$ 0,000.00	100		\$ 0,000.00	85	Partial funding.	\$25,000.00	90	Would allow same as are soccer sign. Aesthic value to City.	\$ 0,000.00
9	MWC ire Department	escue Boat	\$3, 9.00	80		\$3, 9.00	15	ow many rescued Who did helped ow many live by cree s eed some stats.	\$3, 00.00	70	ave it a 70, but not convinced the need for this.	\$3, 9.00	95		\$3, 9.00	27	Measure of success unclear; hypothetical potential future state; fire department budget potentially could cover; i.e. e uipment.	\$3, 9.00
2	The Timbers omeowners Association	Cottonwood Tree emoval	\$9,000.00	83		\$9,000.00	35	Why doesnt t the neighborhood raise \$ w the school themselves	\$9,000.00	95	They did get 3 otes. Appreciate the Principal submitting support of this.	\$9,000.00	85	Private neighborhood.	\$,000.00		Cottonwoods are prevalent trees in MWC, not specific to these 3. imited citizen benefit beyond Timbers.	\$9,000.00
2	MWC Communications	Community mprovement rant Program Branding	\$3,500.00	8		\$3,500.00	0	Can t you have a contest for a MWC logo brand Aren t their film students who need a pro ect	\$3,500.00	100	Absolutely needed.	\$-3,500.00	80		\$3,500.00	35	Already available through City website. Why not use community groups City budget could be used.	\$3,500.00
31	MWC PWA	Electronic Mar uee for Public Wor s	\$55,000.00	92		\$55,000.00	10	Who is going to manage all of these signs	\$55,000.00	100		\$55,000.00	85	Partial funding.	\$25,000.00	35	Why not use City Website City budget	\$55,000.00
28	MWC PWA	ence Beautification Pro ect	\$275,000.00	91		\$275,000.00	0	We ust increased ta es for this type of thing- sn t it the B D ET for the golf course remodel	\$275,000.00	100		\$275,000.00	70	ot necessary.	\$0.00	55	Overall aesthetics to main City feature. City budget available. afety additional feature.	\$275,000.00
27	MWC Tree Board MA	E 15th T sland Beautification	\$129,000.00	85		\$120,000.00	0	ouldnt have this been budgeted BE O E the did the rewor on 15th t- instead of hoping for a grant.	\$129,000.00	A	Abstain Member of the Tree Board		85	alf funding.	\$ 5,000.00	5	City budget. Cost effectiveness for value gained.	\$129,000.00
25	Thic Descriptions	The appy, calthy, Whole, Community ealth initiative	\$1 ,090.50	0	Can we pay insurance, payments, and printing ess that and bundles.	\$8,7 2.50	31	appreciate their research but a 5 page proposal- get lost in the details at the end.	\$1 ,000.00	95		\$1 ,090.50	50	Outside business.	\$0.00	20	ustainable. Participant pro ections Other programs in place to meet this need.	\$1 ,090.50
1	reenhaw Property, C	emodol for Ollies Bargain Outlet at 1 01 ateway Plaza	\$58,790.00	5		\$58,790.00	5	s this a public building	\$58,000.00	80	eed to eep the plaza up in appearance and need it fully occupied. ot familiar with Ollie s, but concern is MWC is getting too many budget stores. An area with a lot of budget stores, surplus etc. is indicative of low income population, ma ing it difficult to attract other businesses.	\$58,790.00	80	Private business.	\$0.00	20	iability of loan not supported. istory of blight avoidance not evident. uccess of potential tenant un own unsupported.	\$58,790.00
			\$1,152,679.08															

#6 Score	#6 Note	#6 Rec. Funding	#7 Score	#7 Note	#7 Rec. Funding	#8 Score	#8 Note	#8 Rec. Funding	#9 Score	#9 Note	#9 Rec. Funding	# of Evaluations	Total Scores	Score divided by #	Average of Rec. Funding	Final BOG Recommendations Per Application	Running Total of Final BOG Recommendations
100		\$3,395.78	A	Abstain Member of the Mid-Del school Foundation		9	Program evaluation measure of green tie very good.	\$3,395.78	90		\$3,395.78		579	9.5	\$3,395.78	\$36,395.20	36,395.20
100	Absolutely needed, health issue.	\$10,000.00	90		\$10,000.00	93	One estimate mentions a 1 tan may need larger due to size of inhabitants. Can low volume shower heads be funded	\$15,000.00	100		\$10,000.00	9	88	9.2	\$10,555.5	\$10,000.00	46,395.20
100		\$20,000.00	100		\$20,000.00	99	Recommend restriction be transfer freezers to regional food Ban if program discontinued.	\$20,000.00	100		\$20,000.00	9	87	9.1	\$20,000.00	\$20,000.00	66,395.20
100		\$9,100.00	100		\$9,100.00	99	Recommend restrictions be transfer refrigerators to regional food Ban if program discontinued.	\$9,100.00	100		\$9,100.00	9	8	93.7	\$9,100.00	\$9,100.00	75,495.20
90	ould be a one time re. uest.	\$23,000.00	A	Abstain Member of the Mid-Del school Board	\$23,000.00	9	Where is their letter	\$23,000.00	80		\$23,000.00		527	87.8	\$22,752.38	\$23,400.00	98,895.20
100	afety priority.	\$15,000.00	100		\$15,000.00	50	o cost estimates or uotes . Proposal mentions several installed in past-one time rule violation	\$15,000.00	85		\$15,000.00	9	755	83.8	\$1,111.7	\$15,000.00	113,895.20
90	Recommend a partial funding for this re. uest.	\$22,013.80	77		\$22,013.80	85	oint benefits with dog par and new animal control center.	\$22,013.80	95		\$22,013.80	9	77	83.0	\$39,555.18	\$44,013.80	157,909.00
100	A much needed Program.	\$50,000.00	90		\$50,000.00	7	Will 10 more owner-occupied homes in Original Mile move the 51 up much and if it did who would now Would the community notice it ow can this be considered when proposes 18 month disbursement and re urement is 12 months	\$50,000.00	80		\$50,000.00	9	7	82.	\$7,222.22	\$50,000.00	207,909.00
90	Recommend partial funding.	\$37,900.00	95		\$37,900.00	5	Pres Eval was by person not as program - what happens after 12 months	\$37,900.00	100		\$37,900.00	9	722	80.2	\$2,300.00	\$37,960.00	245,869.00
100		\$1,000.00	85		\$1,000.00	100	Well done all way around, concise. Where is determination letter	\$1,000.00	90		\$1,000.00	9	717	79.	\$15,111.11		245,869.00
90		\$25,000.00	90		\$25,000.00	5	Where is the determination letter Applicant status not indicated.	\$25,000.00	100		\$25,000.00	9	712	79.1	\$25,000.00	\$25,000.00	270,869.00
90	ould be a one time re. uest.	\$25,000.00	85	Did not send picture of old sign. Only one estimate for the sign. do feel that new signs improve the appearance of the school and will help with information.	\$25,000.00	85		\$25,000.00	80		\$25,000.00	9	701	77.8	\$23,888.89	\$25,000.00	295,869.00
100	A much needed regap program.	\$50,000.00	90		\$50,000.00	2	Middle income-why not get a E OC Approaches funds transfer MWC A to M M P and then M P criteria ic s in. ow can this be considered when proposed to use funds over 2 yr. period and not within re ured 12month period	\$50,000.00	80		\$50,000.00	9	9	77.1	\$1,111.7	\$50,000.00	345,869.00
85	This should include evidence 2-3 year report of need. would recommend partial funding.	\$15,000.00	100		\$20,000.00		o cost uotes.	\$20,000.00	5		\$0.00	9	73	7.7	\$17,222.22	\$19,182.00	365,051.00
95	Recommend partial funding.	\$25,000.00	A	Abstain ose tate College egent	\$50,000.00	50	Big miss - how many students pro ected to run thru program ref. E f cobots not eligible how can BO fund \$25 for curriculum when it is not as ed for Dependency	\$50,000.00	90	Cobots not eligible so recommend we offer to fund the curriculum of \$25,000.	\$25,000.00	7	521	7.	\$0,250.00	\$0.00	365,051.00
100		\$100,000.00	90		\$100,000.00	5	This is a transfer of funds from the MWC A to MWCEDA; no definitive pro ects are specifically detailed, further the MWCEDA criteria will be substituted for this BO . Businesses with those issues can apply to the MWC A and be evaluated.	\$0.00	75		\$0.00	9	5	73.8	\$72,222.22	\$50,000.00	415,051.00
80	ould consider fundraising pro ect for at least half the re. uest.	\$30,000.00	95	Would li e to ow how many estimates from different sign companies if any.	\$0,000.00	38	o cost details or uotes.	\$0.00	80		\$0.00	9	3	73.	\$39,111.11	\$40,000.00	455,051.00
100	Community safety.	\$3,900.00	100		\$3,900.00	58	Cheaper same boat available via oogle search; cost effective ding. o detailed list-ma e model part .	\$3,900.00	100		\$3,900.00	9	5	71.	\$3,315.00	\$3,449.00	458,500.00
90	Health of the community and students is a priority.	\$9,000.00	77	Are there any other cottonwood trees nearby d thin if they are removed it would benefit the playground for sure.	\$9,000.00	3	o determination letter. Trees are on north side of school and bloom spring when winds blow from south. Assertions of OA President that property values are down, yet his property has appreciated.	\$0.00	90		\$9,000.00	9	2	71.3	\$7,111.11	\$0.00	458,500.00
100	ong overdue promotion plan.	\$3,500.00	85		\$3,500.00	5		\$3,500.00	90		\$3,500.00	9	32	70.2	\$3,500.00	\$3,500.00	462,000.00
80	ould be in favor of partial funding. This re. uest did not identify the street.	\$0,000.00	100		\$55,000.00	5	o cost estimates or uotes .	\$0.00	75		\$0.00	9	22	9.1	\$37,777.78	\$38,000.00	500,000.00
85	Only in favor of partial funding - should consider other funding options for fence.	\$137,500.00	90	would li e to see a couple of detailed estimates on the cost of the fence.	\$275,000.00	30	o uotes or cost details.	\$0.00	80		\$0.00	9	01	.7	\$18,055.5	\$0.00	500,000.00
90	reat beautification pro ect; however, would only be in favor of granting full funding, if other re. uest with more necessary needs have been addressed. Recommend partial funding.	\$8,000.00	85		\$129,000.00	0	ac of cost estimates. Officers of Municipal Authority missing ac mission statement	\$0.00	90		\$129,000.00	8	520	5.0	\$98,375.00	\$0.00	500,000.00
95	Recommend partial funding.	\$10,925.00	85		\$1,090.50	0		\$10,925.00	55		\$0.00	9	551	1.2	\$10,887.8	\$0.00	500,000.00
90	Recommend partial funding.	\$0,000.00	80		\$58,790.00	28	ole uote submitted e clusions do not meet Ollies re irements which uestions budget and timeline. TBD mgmt. team to be hire, high ris on mgmt. capacity.	\$0.00	70		\$0.00	9	538	59.7	\$37,017.78	\$0.00	500,000.00
																\$500,000.00	\$7,686,838.20

Grant #2

From: drhoades33 <drhoades33@gmail.com>
To: Jill Donaldson <JDonaldson@MidwestCityOK.org>
Date: 1/23/2019 2:35 PM
Subject: Re: Board of Grantors' Initial Evaluations for the FY 2018-19 MWC Community Grant Applications

Thank you for the opportunity to address the committee's comments and questions. We hope the following information will be helpful to you.

#2 The homeowners association would expect Soldier Creek's fundraising to be focused on student learning. This grant is intended to improve air quality for everyone in the neighborhood, including the school community, the businesses, and residents. School funding should not be diverted for this health initiative.

#4 The Timbers is not a private, gated neighborhood. It is located on a public street accessible to and used by school patrons, customers of local businesses, etc.

#5 Cottonwood trees are prevalent in Midwest City. The removal of these three trees (the only known cottonwoods in this neighborhood) would still have a direct benefit to this community even if it is not a 100% solution for the entire city.

#8 The homeowners association was told that we didn't need to submit an IRS letter of determination with the application. We have a non-profit certificate of incorporation from the Secretary of State and a tax ID number. These documents can be provided if necessary. b) While the cottonwood trees are located to the north of the school, the wind blows from all directions and, thus many areas are affected. c) The HOA did not put property values at issue, only the air quality. The health benefit would affect not only homeowners, but also the school and surrounding businesses.

We appreciate your further consideration of our application. David Rhoades

Sent via my Samsung Galaxy, an AT&T 4G LTE smartphone

----- Original message ----- From: Jill Donaldson <JDonaldson@MidwestCityOK.org> Date: 1/22/19



To: Board of grantors
Midwest City community improvement grant

Grant #8

From: Matthew Mercer
President@mwcsoccer.org
Midwest City Soccer Club

I understand there were a few questions regarding our request for two new marquees and I hope to answer those with this letter.

I agree that \$44,000 for a couple marquees seems very expensive and my mouth gaped a bit open when the quote came in. I had originally hoped through frugal spending and volunteerism, we would be able to handle the marquees ourselves. I had originally looked at full color boards, which were way out of reach. I then looked at smaller or cheaper marquees, but they would not have the vandal guard and would be smaller than the current pad. With our current issues of vandalism, the vandal guard seemed necessary. Replacing the current marquees with the same size seemed logical and cost effective for install.

We do have minimal sponsors as of right now, Dicks Sporting Goods and Academy Sports for \$1,000 each a year. I did work over the 2017/2018 season to get ball stop banner sponsors, which profited about \$700. That kind of went to the wayside this season as it was very time consuming on my part getting companies and then keeping signs up in the Oklahoma wind. Mwc Rotary did donate a golf cart to us about a month ago, but that of course is not a cash donation that can be used for other purposes.

As of a week ago, I was finally able to get a parent volunteer to become our fundraising director. He has great ideas to help with fundraising and company sponsors, but nothing solid will probably get rolling till fall 2019. I am hoping to implement a couple things with that fundraising though. I am trying to open talks with the Mid-Del School Sports Director. I am hoping to develop a relationship with the school system where we can send one of our club coaches to the elementary and middle schools during PE classes to conduct soccer activities. Not every school every day, but a couple of schools a week maybe. This should be mutually beneficial as it would hopefully create a fun physical activity at the school and create interest in soccer. Unfortunately, soccer isn't a huge sport in the Mid-Del High Schools and we tend to get a lot of our younger players from CNP Schools. The coach would of course need to be paid something and I am looking towards our new fundraising director to pull that off.

Secondly, we currently offer scholarships for families that can't afford soccer. That is funded through our adult soccer league that we started about 3 years ago. \$25 of every registration goes to our scholarship fund. Unfortunately, participation in that league has declined each season and I am



concerned it may not survive. I am looking for a parent volunteer to head that program and hopefully get it growing again. Our new fundraising director is already looking for companies that are willing to sponsor our scholarship program. If he is successful, we will then seek out partnerships with schools and lower income programs to offer free registrations, jerseys, equipment and camps.

I contacted Stewart Signs because they had just installed a sign for the Elks Lodge, which is just west of our south entrance on SE 15th Street. Figured if they just completed one there, they would know all appropriate ordinances and proper install methods for our city. I believe they also handled the Mid-Del Schools, but not 100% sure at this point. I did send out quote requests through our club Facebook and mass email, with no replies. I google searched the metro OKC area, attempted to contact the company that installed the cities led sign at the entrance to the community center on N Midwest Blvd, researched websites and just didn't get much interest from local companies. Stewart Signs did a great job of producing the graphics, quotes, staying in contact with updates and such that I felt they knew what they were doing and would be there to help with whatever in the end.

With the future animal adoption center directly across from our current sign on E Reno Ave and the improvements coming to the parks, it would seem logical to upgrade a marquee that is outdated and run down. No, it is not directly related to the animal adoption center nor the dog park, but my guess would be that people entering the dog park will relate a marquee with the MWC Soccer Club logo as part of the city. A new up to date sign will be way more impressive than the current one. As for our south sign on SE 15th? That is located at the entrance to the cities holiday lights display, so it is seen by thousands of visitors each year. Again, an up to date sign will be way more impressive and can be used to direct people into the holiday lights display or any other related information the city would like to post.

Sorry for the length of this letter, but I wanted to do my best to clear up any questions or concerns. Thank you for taking the time to evaluate our grant request and if you have any further questions, feel free to contact me by email or cell phone, (405)760-9696.

A handwritten signature in black ink, appearing to be "M. Allen".

Grant #10

I would like to thank you for the opportunity to address questions regarding the Leah's Hope grant application.

1. How many homeless are in Midwest City?

With a population of 57,308 per the 2017 Census estimates, there are 67% Caucasian, 20% African American, 4% Native American, 1.4% Asian, 6.8% Hispanic and 6.1% of 2 or more races. While the median household income is \$46,431, there are 15.6% living in poverty. Of those living in poverty, 22.5% are children, 13.7% did not graduate high school, and 5.3% are unemployed.

At the close of the 2017-2018 Mid-Del school year, there were 2,401 children who qualified for McKinney-Vento services. Approximately 2 out of 10 students in the school district are personally affected by homelessness. The McKinney-Vento Homeless Assistance Act of 1987 is a United States federal law that provides federal money for homeless shelter programs.

2. Sustainability after 12 months

Leah's Hope will continue to build upon various funding resources in order to maintain a viable and life-changing program. We recently held a luncheon that proved to be not only financially successful but gave our organization an opportunity to build our donor base and educate the public on the mission of Leah's Hope. Our fundraising and collaboration efforts will continue in Eastern Oklahoma County and beyond so that we may grow our private and corporate donors and enable the organization to flourish for years to come.

3. Leah's Hope uniqueness to Midwest City

Leah's Hope will provide housing for families that are seeking employment. Our staff will offer the support necessary to our beneficiaries to find meaningful employment. This is a unique feature of our program. Other agencies in Midwest City that provide housing for homeless families require current employment before being accepted into their organization's housing program.

Best Regards,

Laura Kerr
Executive Director
Leah's Hope



Public Works Administration

Vaughn Sullivan, Director

vsullivan@midwestcityok.org

R. Paul Streets, Assistant Director

rstreets@midwestcityok.org

Grant Responses For Applications #17, 27, 28, 29, 30, 31 & 32

Grant #17 Expand Parking lot and add ADA compliance at Kiwanis Park:

Sales tax will not cover this project because the Parks and Recreation sales tax has not been increased since its inception in the mid 90s

The Midwest City Kiwanis Club is a not for profit civic club they have no 501C3 status with the IRS.

Grant #27 Landscape of islands on S.E. from Westminster to Anderson:

This road improvement project was funded with federal highway dollars and constructed by ODOT. The landscaping and irrigation were not in the original design because ODOT will no longer fund irrigation and landscaping on federal aid projects.

Total estimated cost of the project was included and was based on landscaping contractors per square foot budgetary figures. Itemized breakdown for each component will not be available until final design is completed.

Grant #28 Joe Barnes Regional Park/John Conrad Golf Course Fence:

This fence is ornamental and is a park enhancement/beautification project to be enjoyed by golf course and park patrons.

Grant #29 Purchase and Relocate the Lions Park Sign:

We typically only work with one vendor to develop budgetary estimates. A more competitive process will be used for the final procurement and installation.

This is not an additional sign. This would replace an old style marquee with plastic letters which must be manually changed weekly.

Grant #30 Purchase a Trailer Mounted Impact Attenuator:

This is a cost cutting, life safety piece of equipment. We currently use heavy pieces of equipment with a driver in the cab as crash protection for our employees during working operations. These pieces of equipment have no attenuator capabilities and place the driver at risk. We have no attenuating device to leave in the roadway when roads are left in disrepair during nonworking hours, for example, this device can be attached to a dump truck and parked in the roadway overnight to warn drivers of impending road work ahead. If an inattentive driver were to hit the trailer it is designed to absorb the impact, possibly saving the driver's life.

The number of men/crews who work on the streets varies from day to day depending on the task and personnel available and what department. It is important to point out that this device would be used by multiple departments (Streets, Utilities, Police, Fire) for a wide variety of life saving purposes.

Grant #31 Purchase and installation of a new Public Works/Neighborhood Services Sign:

This is not an additional sign. This replaces an old style marquee with plastic letters which must be manually changed weekly.

The sign is located at 8730 S.E. 15th in front of the Charles J. Johnson and Public Works Administration facilities.

Grant #32 Purchase and Install 3 Emergency Phones:

This is a brand new trail, therefore, a first time project on a newly constructed trail.

Grant #18

From: Brandon Bundy
To: Donaldson, Jill
CC: Gilles, Kellie; Menefee, Patrick
Date: 1/23/2019 4:51 PM
Subject: Answers to questions regarding trail counters: Board of Grantors' Initial Evaluations for the FY 2018-19 MWC Community Grant Applications

Jill,

I have typed a reply if needed to some of the questions. I should be available tomorrow as well if more come around.

(#1) "Wouldn't this be covered under the sale tax increases?" / (#5) "City budget available": The sales tax largely went to operating expenses of the general fund. The counters and this project would likely have to be budgeted through parks and recreation if general funds were used. Unfortunately, the parks and recreation budget is small and the demand for projects is high. This project will help get future federal funding and is a long term gain for the city. A long range project like this does not fit within the standard short term priorities of pool, playground, golf, etc. which are requested by the general public.

(#5) "Benefit to whom?": This project's goal is to count traffic on our highest use areas. By quantifying this traffic; the city can use the data to compete for future federal funding. As it is; Midwest City has to compete for these funds against OKC, Edmond, Norman, etc. and we need any advantage we can receive. These federal funds typically are matching in the order of 80/20 and allows us to leverage the money for larger and better projects across the city.

(#5) "Measure of success": The project will be successful once installed. The counts will be used long term in every application the city makes more future federal trail money. Projects include expansion of the current network, changing the sidewalk to trail along SE 15th/Douglas, and reconstructing trails that are currently asphalt and in need of replacement.

Grant #22



6420 SE 15th St | Midwest City, OK 73110 | 405.733.7673 | rose.edu

January 23, 2019

Board of Grantors
Midwest City Hospital Authority Trust
100 N. Midwest Boulevard
Midwest City, OK 73110

Board of Grantors:

Cobots, also known as collaborative robots, are designed to work beside or cooperatively with people in all settings. This creates opportunities for employees to thrive, while enhancing manufacturing processes. As Rose State ventures to grow a robotics program through Workforce there is intrinsic value to the manufacturers in the Midwest City area and the Aerospace community supported by those manufacturers.

Below are responses from Rose State College Workforce Development to questions asked by the Board of Grantors.

"Cobots not eligible so recommend we offer to fund the curriculum of \$25,000." and "Recommend partial funding."

At the time Rose State submitted our request for funding, it was not clear that the direct purchase of cobots was explicitly ineligible. Although our funding request focused on the acquisition of the cobots themselves, our proposal made it clear that curriculum development was an essential aspect of the long-term success of the program.

After learning that the direct purchase of cobots was not allowed, Rose State College began searching for other ways to fund their purchase. We believe we can do so using either institutional funds or federal grant dollars. BOG funding dedicated to curriculum development would be extremely helpful to the implementation of the program. It would eliminate lag time in the development process.

"Big miss – how many students projected to run through program? (Ref. E) If cobots not eligible how can BOG fund \$25,000 for curriculum when it's not asked for? Dependency..."

Workforce development is integral to economic development and job creation. The proposed cobot program does not look like the "traditional" education that Rose State provides. However, the training being developed can be used by some 400 businesses throughout the metro area including many in Midwest City and others working on various programs at Tinker Airforce Base.

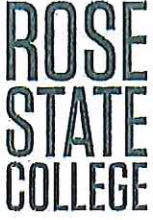

ABI Research, a market-foresight advisory firm providing guidance on the most transformative technologies, has identified collaborative robotics as one of the fastest growing segments of robotic systems.

Small-to-medium sized businesses are driving the increased demand for collaborative robots, as cobots provide solutions that allow for a more flexible kind of manufacturing that makes no assumptions to volume levels or types of products being manufactured.

From 2016 to 2025, the global revenue of collaborative robotics shipments is set to enjoy a compound average growth rate of 49.8 percent, compared to 12.1 percent for Industrial robot and 23.2 percent for Commercial robotics. Based on that level of growth, Rose State expects hundreds of businesses and employees to participate in this program.

Rose State College has a long and successful history of providing industry specific training to working professionals. The Professional Training Center on our campus was built for just that purpose. The cobot program will be the next chapter in that history. Additionally, elements of the curriculum developed using BOG funds will be incorporated into traditional engineering and technology classes at Rose State by the spring semester of 2020 - further expanding the reach and impact of the program.

We believe these responses cover your questions and thank you for your time and the opportunity for Rose State to share its vision for the future.

Respectfully submitted,

A handwritten signature in cursive script that reads "Tamara Pratt".

Tamara Pratt
Rose State College

Grants # 23 + 24

From: Terri Craft
To: Jill Donaldson
Date: 1/23/2019 12:03 PM
Subject: Re: Board of Grantors' Initial Evaluations for the FY 2018-19 MWC Community Grant Applications

Hi Jill:

In response to comments, I'd like to provide some clarification.

Middle Income Housing Rehab Loan Program - Grant Appl. No. 24:

A reviewer indicated that the income levels did not match with the Original Mile Homebuyer Assistance Program application submitted. I have reviewed both applications and did not see any discrepancy in the 80 to 120% income range referenced. *In paragraph A, it states the Middle Income Housing Rehab Loan Program would mirror the existing program in all areas other than income eligibility - see attached brochure for existing program.* The brochure has income limits for households under 80% of median income. Perhaps this is causing the confusion.

Why a city program vs a HELOC? Many applicants are older, the no-interest aspect is appealing and the vetting of work and contractors by our staff provides assurance that they are not being taken advantage of.

Original Mile Homebuyer Assistance Program - Grant Appl. No. 23

A reviewer indicated that this activity would not increase overall homeownership in the area significantly. They are correct however this activity in conjunction with other activities/development, both city initiated and private, in the planning and construction stages will generate continued interest in the area. The five-year residency requirement (property lien) may keep a homeowner here long enough to put down roots and stay in Midwest City.

Hope this helps. Thank you.

Terri L. Craft
Grants Manager
City of Midwest City
405-739-1217
tcraft@midwestcityok.org

Grant #25

From: Jill Donaldson
To: HA BOG
CC: Heather Poole; Sara Hancock; Tim Lyon; williams@wbfbllaw.com; Council
Date: 1/24/2019 11:17 AM
Subject: Re: Response to Grantors - Applicant #25

Thick Descriptions: The Happy, Healthy, Whole Community Health Initiative (Comments Response)

#1: Yes. You would be able to purchase the insurance, permits, printing , and bundles .

#2: Our proposal is lengthy; however, Thick Descriptions wanted to make sure that we thoroughly researched the health status of the Midwest City community to develop an appropriate program to increase the health outcomes of all citizens.

#4: Thick Descriptions is a not an outside business. We are a non-profit organization that provides services to Midwest City youth and their families.

#5: The project we propose is sustainable. Our participant projects are: n=200. We arrived at this number by exploring the number of services offered in the areas that we have outlined, examining which of these areas are identified as food insecure, and comparing these two variables with the total number of residents, and past program participants. The program that Thick Descriptions proposes is comprehensive. There are no programs in the areas that we defined in our proposal that are similar.

***Thick Descriptions would welcome and be appreciative of partial funding.**

Grant #26

From: Claudia Deakins
To: Jill Donaldson
Date: 1/22/2019 12:14 PM
Subject: Re: Board of Grantors' Initial Evaluations for the FY 2018-19 MWC Community Grant Applications

Jill,

Following are the answers to the questions on the spreadsheet about my proposed project #26:

1) Can't we have a contest for a MWC logo/brand? Aren't their film students who need a project?

We could certainly conduct a contest for graphic design students for the logo, and for video production students for the video. The Chief Communications Officer has done this in the past and from experience found it to be very time consuming. The students need a lot of direction and have a lot of questions throughout the semester, especially when it comes to video production. The end result when students have been used in the past has never been a professional product, especially with videos. Since we only have one staff person in communications, the City doesn't have the staff capacity to closely monitor and direct students throughout their semester on our projects. The logo would be produced by graphic design students, and the video by video production students so there would be two student groups to direct, answer questions, set up the interviews, and monitor the design, filming, editing and final production. When we utilize a professional firm, they need minimal direction and produce a professional product because they are highly experienced. This contributes to the image of the City as being professional, competent, experienced and polished.

In one specific experience, the Chief Communications Officer worked with college students in another community to produce a video about the animal shelter. The students needed constant direction, had many questions, needed help setting up interviews, and in general required a lot of staff time. Ultimately after all of the investment of time, they failed to produce a video that was even usable due to their lack of experience in filming and editing.

Another project yielded usable results but still required a great deal of staff time throughout the entire semester project.

2) Already available through the website. Why not use community groups? City budget could be used.

We have promoted the grant application process through our website in the past. We have also utilized all of our social media platforms. We could continue to do this, using the city budget as we have in the past. Our goal was to better explain the grant in order to attract better, more qualified applicants than we have been attracting.

The advantage of the logo would be making sure the community is aware of the name change, and branding the grant with a logo that could be used every year for increased awareness. Over time, the logo would be recognized as being the "Community Grant" logo. We could even ask the recipients of the grants to utilize the logo in/on their projects where applicable and feasible.

>>> Jill Donaldson 1/22/2019 11:28 AM >>>

Hi all,

Please see the attached spreadsheet of the initial (not final) total averages, total recommend funding averages, and comments/questions. The Board of Grantors will meet this Thursday, January 24th. If you would like to answer any of the questions posed on the spreadsheet, please email me before Thursday afternoon and I will relay your answers and comments to the Board of Grantors for their consideration before the final evaluations and recommendations are voted upon to present to the Hospital Authority Trustees in February. I apologize for the small font as it is a lot to get into a spreadsheet. You may need to enlarge the PDF.

Thank you,

Jill Donaldson, Executive Assistant
Midwest City
City Manager/Council
100 N. Midwest Boulevard,
Midwest City, OK 73110
Office: 405.739.1204
jdonaldson@midwestcityok.org
www.midwestcityok.org

"Integrity is doing the right thing. Even when no one is watching [or listening]." C.S. Lewis

Claudia Deakins
Chief Communications Officer
City of Midwest City
100 N Midwest Blvd | Midwest City OK 73110
405.739.1206 (O) | 405.739.1208 (F)
www.midwestcityok.org

"A city is not gauged by its length and width, but by the broadness of its vision and the height of its dreams." ~ Herb Caen, American Journalist

MWC Hospital Authority GRANT RECIPIENTS 2017-18

GRANT RECIPIENT	PURCHASE ITEM	AWARD AMOUNT	EXPENDITURES	MONEY RETURNED	BALANCE	REMARKS
MWC Police	FARO Technologies Hardware & Software	\$78,811.00	\$46,542.34		\$32,268.66	
The Eden Clinc, Inc	Increased Medical Services	\$30,000.00	\$22,970.77		\$7,029.23	
MWC Fire	Gas ID Analyzer	\$61,000.00	\$61,000.00		\$0.00	
MWC Fire	Gas Monitors	\$14,400.00	\$14,400.00		\$0.00	
MWC Fire	Child Passenger Safety Restraints	\$2,030.25	\$2,030.25		\$0.00	
MWC Fire	Triage Kits	\$12,808.44	\$12,808.44		\$0.00	
Carl Albert High School	Water Bottle Filling Stations	\$1,040.21	\$1,012.06		\$28.15	
Autumn House, Inc.	Installation of Wireless System	\$26,645.50	\$26,645.50		\$0.00	
MWC Public Works	Excavation Safety Response Unit	\$67,000.00			\$67,000.00	
Carl Albert Band Booster	Band Trailer	\$22,500.00	\$9,750.00		\$12,750.00	
Oklahoma Earthbike Fellowship	SCIP Maintenance	\$4,500.00	\$3,625.00		\$875.00	
MWC Senior Center	Senior Center Aquarium Project	\$2,520.00	\$2,519.99	0.01	\$0.00	
Friends of the OK History Center, Inc.	Restore & Interpret Historic C-47	\$10,000.00			\$10,000.00	
MWC Com. Dev.	Drone	\$5,000.00	\$4,504.00		\$496.00	
MWC Com. Dev.	Ridgecrest Neighborhood Entrance Sign	\$2,200.00	\$2,200.00		\$0.00	
MWC Grant Dept.	Dana Brown Cooper Head Start - Facility Improvements	\$4,100.00	\$4,100.00		\$0.00	
MWC Public Works	Regional Trail Exercise Stations	\$15,000.00			\$15,000.00	
MWC High School	Keeping Bombers Brilliant with B-1 Technology	\$90,444.60	\$90,444.60		\$0.00	
	Total of recommended grants awarded	\$450,000.00				
MWC HS Museum, Inc. - Vietnam Memorial Project	Additional Matching Funds Awarded by the Hospital Authority Trustees	\$90,000.00			\$90,000.00	
	Total funds awarded	\$540,000.00	\$304,552.95	\$0.01	\$235,447.04	
	Current year funding approved by Council				\$540,000.00	
	Total FY 17-18 Grant Expenditures				304,552.95	
	Monies Returned to Hospital Authority Account				0.01	
	Total FY 17-18 Grant Monies Remaining				235,447.04	
	Totaling				540,000.00	

MWC Hospital Authority GRANT RECIPIENTS 2016-17

GRANT RECIPIENT	PURCHASE ITEM	AWARD AMOUNT	EXPENDITURES	MONEY RETURNED	BALANCE	REMARKS
MWC Chamber	MWC/Tinker 75th Anniversaries	\$209,956.00	\$209,956.00		\$0.00	
Friends of the OK History Center	MWC Historic C-47 Exhibit	\$75,000.00	\$22,970.77		\$52,029.23	
Divine Wisdom Worship Center	Van	\$25,000.00	\$25,000.00		\$0.00	
Mid-Del Public Schools	John Deer Gator	\$21,304.00	\$21,304.00		\$0.00	
MWC Parks & Rec.	Shuttle golf cars	\$20,000.00	\$17,918.86	\$2,081.14	\$0.00	
MWC Com. Dev.	Changeable Message Sign	\$18,500.00	\$15,336.40	\$3,163.60	\$0.00	
MWC Parks & Rec.	Mid-America Park Master Plan Proposal	\$16,000.00	\$15,550.00	\$450.00	\$0.00	
Rose State College Foundation	MWC Heritage Day	\$15,000.00	\$12,411.02	\$2,588.98	\$0.00	
Kiwanis Club	Blue Lights at Kiwanis' Park	\$10,000.00	\$7,338.00	\$2,662.00	\$0.00	
MWC Parks & Rec.	Blue Lights at Lions Park	\$10,000.00	\$7,338.00	\$2,662.00	\$0.00	
Eden Clinic	Pregnancy and Wellness	\$10,000.00	\$10,000.00		\$0.00	
Rose State College	OK Businssess Conference	\$9,450.00	\$8,758.00	\$692.00	\$0.00	The Conference is scheduled for 02-28-18.
MWC Fire	Equipment upgrades	\$9,790.00	\$9,790.00		\$0.00	
					\$0.00	
	Total Award Amount	\$450,000.00				
	Sub-Totals		\$383,671.05	\$14,299.72	52,029.23	
	Current year funding approved by Council	\$450,000.00				
	Total FY 16-17 Grant Expenditures				383,671.05	
	Monies Returned to Hospital Authority Account				\$14,299.72	
	Total FY 16-17 Grant Monies Remaining				52,029.23	
Updated 11/10/16 JD	Totaling				450,000.00	

MWC Hospital Authority GRANT RECIPIENTS 2015-16

GRANT RECIPIENT	PURCHASE ITEM	AWARD AMOUNT	EXPENDITURES	MONEY RETURNED	BALANCE	REMARKS
MWC Police	Protective Cooling Vests for 2 K-9s	\$1,175.94	\$1,175.94		\$0.00	
MWC Police	Training Simulator	\$146,101.90	\$22,970.77		\$0.00	
MWC Economic Development	Heritage Park Mall Redev. Feasibility Study	\$27,500.00	\$27,500.00		\$0.00	
Mid-Del Schools Foundation, Inc.	Subscribe to Ready to Learn/First Book	\$7,000.00	\$7,000.00		\$0.00	
MWC Community Development	Innovation District Plan	\$62,500.00	\$62,500.00		\$0.00	Requesting a 3-month ext. on 06-27-17
MWC Tree Board	2015 Parklawn Beautification Project	\$38,000.00	\$28,000.00	\$10,000.00	\$0.00	
MWC Tree Board	2015 Hudiburg Dr. Island Irrigation Project	\$28,300.00	\$28,166.77	133.23	\$0.00	
MWC Fire	Fire wish list for equipment	\$100,000.00	\$100,000.00		\$0.00	A grant ext. was granted at the 02-28-17 HA mtg
Rose State College	Amphitheater Modernization	\$8,495.00	\$8,494.84	\$0.16	\$0.00	
Mid-Del Food Pantry, Inc.	Dry Storage Building	\$4,000.00	\$4,000.00		\$0.00	Requesting a 3-month ext. on 06-27-17
MWC Parks & Recreation	Festival Inflatables Project	\$1,927.16		\$1,927.16	\$0.00	This was not enough money for the purchase.
	Total Award Amount	\$425,000.00				
	Sub-Totals		\$289,808.32	\$12,060.55	0.00	
	Current year funding approved by Council	\$425,000.00				
	Total FY 15-16 Grant Expenditures				289,808.32	
	Monies Returned to Hospital Authority Account				-\$12,060.55	
	Total FY 15-16 Grant Monies Remaining				0.00	
Updated 05/20/16 JD	Totaling				277,747.77	

MWC Hospital Authority GRANT RECIPIENTS 2014-15

GRANT RECIPIENT	PURCHASE ITEM	AWARD AMOUNT	EXPENDITURES	MONEY RETURNED	BALANCE	REMARKS
MWC Police - (Capt. Jonathon Goforth)	Wearable Video Camera System	\$61,000.00	\$60,991.39	8.61	\$0.00	On-going do to law passed beginning of Nov. Update: We are going out to bid again for the Body Cams and hopefully will be on the February 23rd Council Agenda.
Rose State College (Cindy Mikeman)	Atkinson Heritage Center Revitalization Project II	\$47,581.00	\$22,970.77	\$24,610.23	\$24,610.23	
MWC Grants Management (Teri Craft)	Midwest City Boys and Girls Club Pilot Program	\$75,000.00	\$75,000.00	\$0.00	\$0.00	
MWC Public Relations (Kay Hunt)	Stories of Christmas	\$91,000.00	\$91,000.00	0	\$0.00	On-going
MWC Fire (Jarett Metheny/David Richardson)	Community Risk Reduction Partnership (CRRP)	\$27,848.26	\$27,738.13	\$110.13	\$0.00	Left a voice mail on 11-2-15
Mid-Del Public Schools (Pam Deering)	Sprigeo - A Safety Initiative	\$16,794.60	\$16,794.60	\$0.00	\$0.00	Sent an email on 11-2-15
MWC Tree Board (Vaughn Sullivan)	29th & I-40 Island Beautification	\$14,800.00	\$14,963.78	-163.78	\$0.00	
MWC Parks and Recreation (Vaughn Sullivan)	Emergency Blue Phone Project	\$38,776.14	\$36,638.98	\$2,137.16	\$0.00	
RSVP of Central OK Inc. (Beth Patterson)	RSVP Provide-A-Ride Medical Trans.	\$1,900.00	\$1,900.00	\$0.00	\$0.00	
MWC Tree Board (Vaughn Sullivan)	Midwest Blvd Street Beautification	\$25,300.00	\$24,990.58	\$309.42	\$0.00	
	Total Award Amount	\$400,000.00				
	Sub-Totals		\$372,988.23	\$27,011.77	\$24,610.23	
	Current year funding approved by Council	\$400,000.00				
	Total FY 14-15 Grant Expenditures				\$372,988.23	
	Monies Returned to Hospital Authority Account				\$27,011.77	
	Total FY 14-15 Grant Monies Remaining				\$0.00	
Updated 11/03/15 - JD	Totaling				\$400,000.00	

MWC Hospital Authority GRANT RECIPIENTS 2013-14

GRANT RECIPIENT	PURCHASE ITEM	AWARD AMOUNT	EXPENDITURES	MONEY RETURNED	BALANCE	REMARKS
City of Midwest City/Fire Dept	Fire Command Training Center	\$32,000.00	\$32,000.00	\$0.00	\$0.00	
City of Midwest City/Golf Course	First Tee National Program	\$10,000.00	\$22,970.77	-\$12,970.77	-\$12,970.77	
City of Midwest City/311 App	City Of MWC Mobile 311 App	\$20,000.00	\$19,924.00	\$76.00	\$0.00	Kay Hunt is including this app in a "Stay Connected" marketing campaign and will use the remaining \$76 as part of the ad campaign. Reminder email sent 11-2-15.
Midwest City Chamber of Commerce	Town Center Electronic Event Billboard	\$80,584.87	\$78,157.21	2427.66	\$0.00	1st half of bill paid on 9/29/16 and 2nd half to be paid upon completion. Due to construction on the site of the Billboard (29th & Air Depot) this grant is extended
MWC Parks and Rec Dept	Mobile Stage	\$155,000.00	\$155,000.00	\$0.00	\$0.00	\$5060.00 authorized for transfer to cover costs. Total spent \$160,000.00
Rose State College - Atkinson	Atkinson Heritage Center Project - landscaping	\$52,415.13	\$52,415.13	\$0.00		
	Total Award Amount	\$350,000.00				
	Sub-Totals		\$360,467.11	-\$10,467.11	-\$12,970.77	
	Current year funding approved by Council	\$350,000.00				
	Total FY 13-14 Grant Expenditures				\$360,467.11	
	Monies Returned to Hospital Authority Account				-\$10,467.11	
	Total FY 13-14 Grant Monies Remaining				\$0.00	
Revised 11/03/15 - JD	Totaling				\$350,000.00	

MWC Hospital Authority GRANT RECIPIENTS 2012-13

GRANT RECIPIENT	PURCHASE ITEM	AWARD AMOUNT	EXPENDITURES	MONEY RETURNED	BALANCE	REMARKS
City of Midwest City/Fire Dept	Firefighter safety & health equipment	\$18,755.00	\$18,755.00		\$0.00	Letter requesting receipts and outcome report sent on 4-8-14, Email request for receipts and outcome reports sent on 6-10-14
City of Midwest City/Golf Course	Replace fence south side golf course	\$50,000.00	\$22,970.77		\$27,029.23	A 6-month extension approved on 3-7-14, Email request for expenditures sent 6-10-14
City of Midwest City/Grants Mgmt	Original mile median improvement project	\$50,000.00	\$50,000.00		\$0.00	A 6-month extension approved on 2-5-14, a 6-month extension approved 11-24-14
City of Midwest City/Police Dept	Covered parking specialty equipment & vehicles	\$14,000.00	\$14,000.00		\$0.00	Outcome Report and expenditures submitted
Midwest City Rotary Club	Erection of Veterans' Memorial - 2 grant year total	\$60,000.00	\$60,000.00		\$0.00	Outcome Report and expenditures submitted
Midwest City Tree Board	SE 15th Street Beautification Project	\$35,000.00	\$32,064.20	\$2,935.80	\$0.00	A 6-month extension approved on 3-7-14
Mid-Del City Public Schools Foundation	Bot Ball educational Robotics	\$25,000.00	\$22,923.38	\$2,076.62		Budget modification approved on 12-2-13, Letter requesting receipts and outcome report sent on 4-8-14, Email request for receipts and outcome reports sent on 6-10-14, Letter to be sent 11-26-2014
Regional Food Bank of OK	Expansion of MWC childhood hunger programs	\$25,000.00	\$25,000.00		\$0.00	Expenditures submitted, Email request for Outcome report sent 6-5-14
YMCA of Greater OKC	Purchase & install addtl. playground equipment MWC	\$22,245.00	\$22,200.00	\$45.00	\$0.00	Outcome Report and expenditures submitted, \$45.00 owed back to the Trust, Email request for the \$45.00 sent on 6-5-14, Letter to be sent 11-26-14; money returned 11-5-15
	Total Award Amount	\$300,000.00				
	Sub-Totals		\$267,913.35	\$5,057.42	\$27,029.23	
	Current year funding approved by Council	\$300,000.00				
	Total FY 12-13 Grant Expenditures				\$267,913.35	
	Monies Returned to Hospital Authority Account				\$5,057.42	
	Total FY 12-13 Grant Monies Remaining				\$27,029.23	
Updated 11/03/15 JD	Totaling				\$300,000.00	

MWC Hospital Authority GRANT RECIPIENTS 2011-12

GRANT RECIPIENT	PURCHASE ITEM	AWARD AMOUNT	EXPENDITURES	MONEY RETURNED	BALANCE	REMARKS
City of Midwest City	Green Machine	\$20,000.00	\$22,970.77	\$1,531.62	\$0.00	money returned to Finance / Extension through 8/1/13
City of Midwest City/Golf Course	Replace fence	\$50,000.00	\$50,000.00		\$0.00	Recipient pd overage \$32,990.75
City of Midwest City/Police Dept.	Segway	\$8,025.00	\$7,533.96	\$491.04	\$0.00	Recipient returned \$491.04 to Finance 11/6/12
City of Midwest City/Police Dept.	Off-road UTV & Trailer	\$12,300.00	\$12,299.63	\$0.37	\$0.00	Recipient returned .37 to Finance 11/6/12
Healing Hearts Health Clinic	Medical & Office Equipment	\$2,000.00	\$2,000.00		\$0.00	Recipient pd overage \$58.82
Kiwani's Club of MWC	2011 Concrete Kiwanis's Park Trails	\$70,000.00	\$70,000.00		\$0.00	Recipient pd overage \$2,248.64
Literacy Link	Adult Literacy Software	\$2,941.35	\$2,899.30	\$42.05	\$0.00	Recipient returned \$42.05 to Finance 11/8/12
Metropolitan Library System	Library Garden Restoration	\$25,000.00	\$19,970.92	\$5,029.08	\$0.00	Recipient returned \$5,029.08 to Finance 2/14/13
Midwest City Rotary Club	Veteran's Memorial project	\$100,000.00	\$100,000.00		\$0.00	Extension through 7/21/13
Rose State College	RSC Pilot Program (6-12 grades)	\$60,500.00	\$60,500.00		\$0.00	Extension through 9/14/13
YMCA Greater OKC	MWC YMCA Community playground	\$29,577.65	\$29,577.65		\$0.00	Recipient pd overage \$422.35
	Total Award Amount	\$380,344.00				
	Sub-Totals		\$377,752.23	\$7,094.16	\$0.00	
	Current year funding approved by Council	\$380,344.00				
	Total FY 11-12 Grant Expenditures				\$377,752.23	
	Monies Returned to Hospital Authority Account				\$7,094.16	
	Total FY 11-12 Grant Monies Remaining				-\$4,502.39	
Updated 11/03/15 JD	Totaling				\$380,344.00	

MWC Hospital Authority GRANT RECIPIENTS 2010-11

GRANT RECIPIENT	PURCHASE ITEM	AWARD AMOUNT	EXPENDITURES	MONEY RETURNED	BALANCE	REMARKS
City of Midwest City - Police Department	Replace Irreparable Speed Sign Trailer	\$16,800.00	\$22,970.77		\$0.00	
Mid-Del Food Pantry	Freezer & Shelving Upgrade Project	\$21,700.00	\$21,700.00		\$0.00	Recipient paid overage \$1,318.44
Mid-Del Group Homes, Inc.	AED's Group Homes & Workshop	\$2,800.00	\$2,800.00		\$0.00	Recipient paid overage \$662.54
Mid-Del Group Homes, Inc.	Mini-bus w/wheelchair accessibility	\$40,000.00	\$40,000.00		\$0.00	Recipient paid overage \$791.50
Mid-Del Schools	Random Student Drug Testing (lab expenses only)	\$25,357.00	\$25,357.00		\$0.00	
Mid-Del Schools - Carl Albert Middle School	Playaways encourage reading (Library equipment)	\$10,000.00	\$10,000.00		\$0.00	Recipient paid overage \$7.83
Midwest City Tree Board	Free container grown trees Arbor Day	\$3,000.00	\$3,000.00		\$0.00	
Oklahoma Honor Flights	Fund 3 flights @ 1/3 increments (as trips occur)	\$50,000.00	\$50,000.00		\$0.00	Recipient paid overage \$192,702.23
	Total Award Amount	\$169,657.00				
	Sub-Totals		\$175,827.77	\$0.00	-\$6,170.77	
	Carryover to FY 2011-12	\$80,343				
	Current year funding approved by Council	\$250,000.00				
	Total FY 10-11 Grant Expenditures				\$175,827.77	
	Monies Returned to Hospital Authority Account				\$0.00	
	Total FY 10-11 Grant Monies Remaining				-\$6,170.77	
Updated 11/03/15 JD	Totaling				\$169,657.00	

MWC Hospital Authority GRANT RECIPIENTS 2009-10

GRANT RECIPIENT	PURCHASE ITEM	AWARD AMOUNT	EXPENDITURES	MONEY RETURNED	BALANCE	REMARKS
City of Midwest City - Community Development Dept.	North Oaks Redevelopment Plan	\$160,000.00	\$22,970.77		\$0.00	Recipient pd overage \$61,558.62
City of Midwest City - Community Development Dept.	Soldier Creek Pedestrian Bridge	\$47,943.46	\$47,943.46		\$0.00	Recipient pd overage \$2,000
City of Midwest City - Fire Department	Low Speed Rescue/Apparatus	\$24,045.00	\$24,045.00		\$0.00	Recipient pd overage \$415.35
City of Midwest City - Grants Management Dept.	Original Mile Enhancement Study	\$40,000.00	\$40,000.00		\$0.00	Recipient pd overage \$21,341.65
City of Midwest City - Police Dept.	Automatic License Plate Recognition	\$20,880.00	\$20,109.00	\$771.00	\$0.00	Recipient returned \$880.00 to Finance
Mid-Del Schools/Cleveland Bailey Elementary	Walking Track	\$18,105.89	\$18,105.89		\$0.00	
Mid-Del Schools/Country Estates Elementary, PTA	Community Fitness Track	\$19,394.65	\$19,394.65		\$0.00	Recipient pd overage \$56.30
Douglas Blvd. United Methodist Church	Feed His People	\$33,800.00	\$33,800.00		\$0.00	Recipient pd overage \$4,578.43
Mid-Del Farmers' Market Association	Equipment & Promotional Materials	\$10,000.00	\$10,000.00		\$0.00	Recipient pd overage \$14.83
Mid-Del Youth & Family Center, Inc.	Seed \$ Charles J. Johnson Youth Dev Ctr	\$41,157.00	\$41,157.00		\$0.00	Extension through 3/10/13, a 6 month extension approved on 11-24-14
	Total Award Amount	\$415,326.00				
	Sub-Totals		\$277,525.77	\$771.00	\$0.00	
	Carryover from 2008-19	\$90,261.57				
	Current year funding approved by Council	\$330,000.00				
	Total FY 09-10 Grant Expenditures				\$277,525.77	
	Monies Returned to Hospital Authority Account				\$771.00	
	Total FY 09-10 Grant Monies Remaining				\$137,029.23	
Updated 11/03/15 JD	Totaling				\$415,326.00	

MWC Hospital Authority GRANT RECIPIENTS 2008-09

GRANT RECIPIENT	PURCHASE ITEM	AWARD AMOUNT	EXPENDITURES	MONEY RETURNED	BALANCE	REMARKS
Choctaw-Nicoma Park Public Schools	Drug Awareness/Drug Testing	\$25,000.00	\$22,970.77		\$2,029.23	
City of Midwest City/Community Development Department	Public Art	\$20,000.00	\$17,374.66	\$2,625.34	\$0.00	Recipient returned \$2,625.34 to Acctg 1/18/11
City of Midwest City/Street Department	City Wide Reforestation	\$150,000.00	\$150,000.00		\$0.00	Recipient paid overage \$2,684.44
Defenders of Dreams	Seek professional assistance to develop Master Plan	\$10,000.00		\$10,000.00	\$0.00	
Mid-Del Group Homes, Inc.	Computers	\$4,000.00	\$4,000.00		\$0.00	Recipient paid overage \$1,001.92
Mid-Del Public Schools Foundation	S.M.I.L.E.	\$35,000.00	\$35,000.00		\$0.00	Recipient paid overage \$1,666.56
Mid-Del Schools/Ridgecrest Elementary	Walking Track	\$28,196.96	\$28,196.96		\$0.00	
Mid-Del Schools/Traub Elementary	Walking Track	\$16,107.47	\$16,107.47		\$0.00	
Mid-Del Youth & Family Center, Inc.	Capital Building Project	\$50,000.00	\$50,000.00		\$0.00	Recipient paid overage \$16.26
Midwest City Chamber of Commerce	Exhibition Display & Equipment Project	\$16,869.00	\$16,869.00		\$0.00	Recipient paid overage \$1,899.90
Rose State College	Continuing Education & Community Services	\$43,565.00	\$37,135.05	\$6,429.95	\$0.00	Recipient returned \$6,429.95 to Acctg 3/8/10
Sustainable East Oklahoma County (OSN)	Mid-Del Farmer's Market Start-up	\$11,000.00	\$11,000.00		\$0.00	Recipient paid overage \$248.90
	Total Award Amount	\$409,738.43				
	Sub-Totals		\$388,653.91	\$19,055.29	\$2,029.23	
	Carryover to FY 2009-10	\$90,261.57				
	Current year funding approved by Council	\$500,000.00				
	Total FY 08-09 Grant Expenditures				\$388,653.91	
	Monies Returned to Hospital Authority Account				\$19,055.29	
	Total FY 08-09 Grant Monies Remaining				\$2,029.23	
Updated 11-03-15 JD	Totaling				\$407,709.20	

22970.77

THERE WERE NO GRANT MONIES AWARDED FOR THIS GRANT YEAR 2007-08

MWC Hospital Authority GRANT RECIPIENTS 2006-07

GRANT RECIPIENT	PURCHASE ITEM	AWARD AMOUNT	EXPENDITURES	MONEY RETURNED	BALANCE	REMARKS
City of Midwest City	Nursing student housing stipend	\$36,000.00	\$22,970.77	\$9,937.22	\$0.00	Recipient returned \$9,937.22 to Finance 1/12
City of Midwest City	Oklahoma Centennial Street Clock	\$40,000.00	\$40,000.00		\$0.00	Recipient paid overage \$10,321.36
Eastern Oklahoma County Tourism Council	Star Spangled Salute	\$85,884.26	\$85,884.26		\$0.00	Recipient paid overage \$5,685.94
Literacy Link	Health Literacy Initiative	\$1,510.00	\$1,507.02	\$2.98	\$0.00	Recipient returned \$2.98 to Finance 6/09
Mid-Del Youth & Family Center, Inc.	Phase I - Emergency Children's Shelter	\$50,000.00	\$50,000.00		\$0.00	Recipient paid overage \$2,125.77
Midwest City Chamber of Commerce	2007 Youth Excel Leadership Program	\$5,000.00	\$4,422.05	\$577.95	\$0.00	Recipient returned \$577.95 to Finance 11/08
Midwest City Martin Luther King Jr. Prayer Breakfast Comm, Inc.	Prayer Breakfast	\$6,000.00	6,000.00		\$0.00	Recipient paid overage \$3,438.00
Project Concern	Project Concern	\$20,605.74	\$20,605.74		\$0.00	Recipient paid overage \$124.06
Studio Mid-Del, Inc.	Construction to complete Community Arts Center	\$250,000.00	\$250,000.00		\$0.00	Recipient paid overage \$1,776.72
Tinker POW/MIA Committee	Construction Community POW/MIA Memorial	\$5,000.00	\$5,000.00		\$0.00	
	Total Award Amount	\$500,000.00				
	Sub-Totals		\$486,389.84	\$10,518.15	\$0.00	
	Total FY 06-07 Grant Expenditures				\$486,389.84	
	Monies Returned to Hospital Authority Account				\$10,518.15	
	Total FY 06-07 Grant Monies Remaining				\$3,092.01	
Revised 1/24/12	Totaling				\$500,000.00	

MWC Hospital Authority GRANT RECIPIENTS 2005-06

GRANT RECIPIENT	PURCHASE ITEM	AWARD AMOUNT	EXPENDITURES	MONEY RETURNED	BALANCE	REMARKS
City of Midwest City/Animal Welfare	Veterinarian Assistance Program	\$12,000.00	\$22,970.77	-\$10,970.77	\$0.00	Recipient returned \$30.00 to Acctg.
City of Midwest City/Animal Welfare	Illuminated Signs	\$5,000.00	\$4,828.00	\$172.00	\$0.00	Recipient returned \$172.00 to Acctg.
City of Midwest City/Animal Welfare	Roof for Facility	\$46,500.00	\$35,480.63	\$11,019.37	\$0.00	Recipient returned \$11,019.37 to Acctg.
City of Midwest City/Com.Devel. Dept.	Consulting Services Development of Rail & Trail Master Plan	\$25,000.00	\$25,000.00		\$0.00	
City of Midwest City/Com.Devel. Dept.	Review & Update City's Subdivision Regulations	\$15,000.00	\$15,000.00		\$0.00	Recipient paid overage \$10,560.36
City of Midwest City/Convention & Visitors Bureau	Sponsorship Assistance	\$10,000.00	\$10,000.00		\$0.00	Recipient paid overage \$1,500.85
City of Midwest City/Emergency Management	CERT Training & Response Supplies	\$5,000.00	5,000.00		\$0.00	
City of Midwest City/Fire Department	Fire Hydrant Locator Reflectors	\$6,500.00	\$6,380.00	\$120.00	\$0.00	Recipient returned \$120.00 to Acctg.
City of Midwest City/Golf (John Conrad)	Complete Concrete Curbs	\$27,500.00	\$27,500.00		\$0.00	
City of Midwest City/Grants Management Dept.	MWC Juvenile Modification Camp	\$15,000.00	\$15,000.00		\$0.00	
City of Midwest City/Parks & Rec Department	Electronic Message Sign - City Hall Complex	\$20,000.00	\$20,000.00		\$0.00	Recipient paid overage \$9,150.00
City of Midwest City/Police Department	Taser Conduct Energy Weapons, Simulator Suite & Taser Cartridges	\$19,095.50	\$19,084.28	\$11.22	\$0.00	Recipient returned \$11.22 to Acctg.
City of Midwest City/Police Department	Digital Video Recorder & Cameras (Detective Division)	\$6,821.49	\$6,821.49		\$0.00	Recipient paid overage \$1,287.14
City of Midwest City/Police Department	Forensic Lab, CSI Vehicle	\$28,462.00	\$28,462.00		\$0.00	Recipient paid overage \$1,673.00
City of Midwest City/Street Department	Landscape & Irrigate Air Depot Blvd. from SE 15th to SE 29th	\$25,000.00	\$24,997.15	\$2.85	\$0.00	Recipient returned \$2.85 back to Acctg.
Eastern Oklahoma County Tourism Council	Star Spangled Salute Celebration	\$35,000.00	\$35,000.00		\$0.00	
Heartline, Inc.	Central Oklahoma 2-1-1 Project Start-up Costs	\$25,000.00	\$25,000.00		\$0.00	Recipient paid overage \$227.29
Holiday Lights Spectacular, Inc.	Upgrade Electric Infrastructure & Refurbish Displays	\$25,000.00	\$25,000.00		\$0.00	Recipient paid overage \$244.67
Literacy Link	Educational Materials for Adult non-readers	\$3,000.00	\$3,000.00		\$0.00	Recipient paid overage \$15.60
Mid-Del Group Homes, Inc.	Delivery Truck	\$20,000.00	\$20,000.00		\$0.00	Recipient paid overage \$3,400.00
Mid-Del Public Schools Foundation	S.H.A.R.P. (Sequoyah books Help Accelerate Reading Progress)	\$1,840.00	\$1,501.68	\$338.32	\$0.00	Recipient returned \$338.32 to Acctg.
Mid-Del Youth & Family Center, Inc.	Play Therapy Room	\$4,425.75	\$4,425.75		\$0.00	Recipient paid overage \$458.72
Midwest City Chamber of Commerce	Youth Excel	\$5,000.00	\$4,958.62	\$41.38	\$0.00	Recipient returned \$41.38 to Acctg.
Midwest City MLK Jr. Prayer Breakfast Comm.	Annual Prayer Breakfast	\$6,000.00	\$6,000.00		\$0.00	Recipient paid overage \$2,664.86
Midwest City Rotary Club #5750	Rotary Pavilion (Regional Park) Water Fountain	\$11,000.00	\$10,942.71	\$57.29	\$0.00	Recipient returned \$57.29 to Acctg.
Midwest City Tree Board	Landscape & Irrigate Phase 2 Reno Ave.	\$46,400.00	\$46,372.31	\$27.69	\$0.00	Recipient returned \$27.69 to Acctg.
	Total Award Amount	\$449,544.74				
	Sub-Totals		\$448,725.39	\$819.35	\$0.00	
	Total FY 05-06 Grant Expenditures				\$448,725.39	
	Monies Returned to Hospital Authority Account				\$819.35	
	Total FY 05-06 Grant Monies Remaining				\$0.00	
	Totaling				\$449,544.74	

MWC Hospital Authority GRANT RECIPIENTS 2004-05

GRANT RECIPIENT	PURCHASE ITEM	AWARD AMOUNT	EXPENDITURES	MONEY RETURNED	BALANCE	REMARKS
City of Midwest City	Electronic Digital Sign	\$29,800.00	\$22,970.77		\$6,829.23	Recipient paid overage \$759.40
City of Midwest City/Convention & Visitors Bureau	Tourism Sponsorship Assistance	\$10,000.00	\$7,640.87	\$2,359.13	\$0.00	Recipient returned \$2,359.13
City of Midwest City/Devel. Services Dept.	Architectural & Engineering Services/Phase I MWC Community Outreach Center	\$40,000.00	\$40,000.00		\$0.00	Recipient paid overage \$37,641.40
City of Midwest City/Devel. Services Dept.	North Oaks Revitalization Plan	\$20,000.00	\$20,000.00		\$0.00	
City of Midwest City/Devel. Services Dept.	Consulting Services/Zoning Ordinance & Subdivision Regulation Overhaul	\$25,000.00	\$25,000.00		\$0.00	
City of Midwest City/Golf Course	Completion Concrete Cart Trails	\$33,000.00	\$32,456.19	\$543.81	\$0.00	Recipient returned \$543.81 to Acctg.
City of Midwest City/Park Department	Reno Swim & Slide Irrigation and Landscape	\$49,388.00	\$49,388.00		\$0.00	
City of Midwest City/Police Department	Fitness Equipment/Police Workout Room	\$20,497.24	\$20,490.00	\$7.24	\$0.00	Recipient returned \$7.24 to Acctg.
Eastern Oklahoma County Tourism Council	Star Spangled Salute	\$35,000.00	\$35,000.00		\$0.00	Recipient paid overage \$11.94
Holiday Lights Spectacular, Inc.	Additional Light Displays & Upgrade Infrastructure	\$25,000.00	\$25,000.00		\$0.00	Recipient paid overage \$2,737.01
Junior Achievement of Greater Oklahoma City, Inc.	Investing in MWC Youth/JA Program Monroney JHS	\$1,000.00	\$1,000.00		\$0.00	Recipient paid overage \$340.00
Literacy Link, Inc.	Networking Hardware, Educational Software/Literacy Computer Lab	\$4,900.00	\$4,900.00		\$0.00	Recipient paid overage \$707.71
Mid-Del Food Pantry, Inc.	New Carpeting/Mid-Del Food Pantry	\$4,855.00	\$4,855.00		\$0.00	
Mid-Del Group Homes, Inc.	8-Passenger Van/Disabled Transportation	\$20,000.00	\$19,046.65	\$953.35	\$0.00	Recipient returned \$953.35 to Acctg.
Mid-Del Group Homes, Inc.	Replace Appliances Group Home	\$4,000.00	\$3,915.34	\$84.66	\$0.00	Recipient returned \$84.66 to Acctg.
Mid-Del Public Schools Foundation	Children Reading Across Mid-Del (CRAM)	\$3,910.00	\$3,525.64	\$384.36	\$0.00	Recipient returned \$384.36 to Acctg.
Mid-Del Schools	Stranger Danger	\$2,500.00	\$2,500.00		\$0.00	
Mid-Del Youth and Family Center, Inc.	Van Purchase	\$12,000.00	\$12,000.00		\$0.00	Recipient paid overage \$5,544.50
Midwest City Chamber of Commerce	Youth Excel	\$4,500.00	\$4,500.00		\$0.00	Recipient paid overage \$54.84
Midwest City Chamber of Commerce	Reduce Loan on Building	\$25,000.00	\$25,000.00		\$0.00	
Midwest City Martin Luther King Jr. Prayer Breakfast Committee	Annual Prayer Breakfast	\$5,000.00	\$5,000.00		\$0.00	Recipient paid overage \$1,101.64
Midwest City Optimist Club	Continued Development/Optimist Park	\$7,500.00	\$7,500.00		\$0.00	Recipient paid overage \$835.34
Midwest City Rotary Club #5750	Volleyball Court/MWC Regional Park/Renovation Project	\$15,000.00	\$14,045.79	\$954.21	\$0.00	Recipient returned \$954.21 to Acctg.
Midwest City Tree Board	Reno Avenue Irrigation and Landscape	\$46,400.00	\$46,400.00		\$0.00	Recipient paid overage \$2,155.11
Project Woman Coalition, Inc.	Operation Outreach Midwest City/Breast Screening	\$8,724.76	\$8,724.76		\$0.00	Recipient paid overage \$504.85
Rose State College	Math & Science Workshops K-12	\$25,125.00	\$14,326.96	\$10,798.04	\$0.00	Recipient returned \$10,798.04
Tinker Inter-Tribal Council	Third Annual MWC Pow Wow	\$8,750.00	\$8,750.00		\$0.00	Recipient paid overage \$18.79
Tinker POW/MIA Committee	Construction Community POW/MIA Memorial	\$13,150.00	\$13,146.72	3.28	\$0.00	Recipient returned \$3.28 to Acctg.
	Total Award Amount	\$500,000.00				
	Sub-Totals		\$477,082.69	\$16,088.08	\$6,829.23	
	Total FY 04-05 Grant Expenditures				\$477,082.69	
	Monies Returned to Hospital Authority Account				\$16,088.08	
	Total FY 04-05 Grant Monies Remaining				\$6,829.23	
	Totaling				\$500,000.00	

MWC Hospital Authority GRANT RECIPIENTS 2003-04

GRANT RECIPIENT	PURCHASE ITEM	AWARD AMOUNT	EXPENDITURES	MONEY RETURNED	BALANCE	REMARKS
City of Midwest City/Animal Welfare Department	Pet Adoption Trailer	\$21,455.00	\$22,970.77		\$0.00	Recipient paid overage \$805.28
City of Midwest City/Municipal Court	Remodel Payment Counter/Lobby Revitalization	\$12,000.00	\$12,000.00		\$0.00	Recipient paid overage \$581.41
City of Midwest City/Neighborhood Services	Neighborhood Gatherings & Cleanup	\$20,000.00	\$19,994.46	\$5.54	\$0.00	Recipient returned \$5.54 to Acctg. 2/10/05
City of Midwest City/Neighborhood Services	Operation Paint Brush	\$10,000.00	\$9,480.34	\$519.66	\$0.00	Recipient returned \$519.66 to Acctg. 1/9/06
City of Midwest City/Police Department	Digital Cameras for CAO's	\$1,197.00	\$1,196.00	\$1.00	\$0.00	Recipient returned \$1.00 to Acctg. 1/18/05
City of Midwest City/Police Department	Jail Entry Equipment	\$2,400.00	\$2,288.46	\$111.54	\$0.00	Recipient returned \$111.54 to Acctg. 1/18/05
Contact Crisis Helpline, Inc.	24-hour Referral Hotline & Staff Program	\$10,000.00	\$10,000.00		\$0.00	
Eastern Oklahoma County Tourism Council	Star Spangled Salute	\$30,000.00	7,223.47	\$22,776.53	\$0.00	Recipient returned \$22,776.53 to Acctg. 2/15/05
Holiday Lights Spectacular	Holiday Lights Display	\$25,000.00	\$25,000.00		\$0.00	Recipient paid overage 663.92
Leukemia & Lymphoma Society	Patient Services Eastern Oklahoma County	\$5,000.00	\$5,000.00		\$0.00	Recipient paid overage 109.35
Literacy Link	Educational Materials	\$2,464.00	\$2,464.00		\$0.00	Recipient paid overage \$48.46
Mid-Del Technology Center	Electric Vehicle Demonstration	\$854.85	\$854.85		\$0.00	Recipient paid overage \$3,240.15
Mid-Del Youth & Family Center, Inc.	Garden Shed, Mower & Equipment	\$6,200.00	\$6,200.00		\$0.00	Recipient paid overage \$335.97
Midwest City Chamber of Commerce	Youth Excel Leadership Program	\$4,000.00	\$4,000.00		\$0.00	Recipient paid overage \$125.32
Midwest City Chamber of Commerce	Complete & Construct New Facility	\$50,000.00	\$50,000.00		\$0.00	Recipient paid overage \$13,356.49
Midwest City Dr. M.L. King Jr. Prayer Breakfast Committee	Annual Prayer Breakfast	\$5,000.00	\$5,000.00		\$0.00	Recipient paid overage \$3,336.68
Midwest City Dr. M.L. King Jr. Prayer Breakfast Committee	Diversity Workshops	\$3,950.00	\$3,894.00	\$56.00	\$0.00	Recipient returned \$56.00 to Acctg. 3/9/05
Midwest City High School/DECA	MWC High Flower Power Project	\$2,339.15	\$2,282.59	\$56.56	\$0.00	Recipient returned \$56.56 to Acctg. 3/7/05
Midwest City Kiwanis Club	Repair & Replace Pavilion Roof	\$26,000.00	\$25,485.00	\$515.00	\$0.00	Recipient returned \$515.00 to Acctg. 2/3/05
Midwest City Optimist Club	Add Development Optimist Park	\$10,000.00	\$10,000.00		\$0.00	Recipient paid overage \$331.33
Midwest City Public Art Board	ARTOklahoma 2004	\$2,140.00	\$1,687.35	\$452.65	\$0.00	Recipient returned \$452.65 to Acctg. 8/1/05
	Total Award Amount	\$250,000.00				
	Sub-Totals		\$227,021.29	\$24,494.48	\$0.00	
	Total FY 03-04 Grant Expenditures				\$227,021.29	
	Monies Returned to Hospital Authority Account				\$24,494.48	
	Total FY 03-04 Grant Monies Remaining				-\$1,515.77	
	Totaling				\$250,000.00	

MWC Hospital Authority GRANT RECIPIENTS 2002-03

GRANT RECIPIENT	PURCHASE ITEM	AWARD AMOUNT	EXPENDITURES	MONEY RETURNED	BALANCE	REMARKS
Choctaw Park Foundation	Veterans Memorial @ Choctaw	\$5,000.00	\$22,970.77		-\$17,970.77	Recipient paid overage \$3,850.25
City of Midwest City/Development Services Dept.	Comprehensive Plan	\$50,000.00	\$50,000.00		\$0.00	
City of Midwest City/Fire Department	Risk Watch Program	\$10,860.39	\$10,860.39		\$0.00	Recipient paid overage \$140.02
City of Midwest City/Fire Department	Thermal Imaging Camera	\$25,800.00	\$25,800.00		\$0.00	
City of Midwest City/Fire Department	Rapid Intervention System	\$4,500.00	\$4,500.00		\$0.00	
City of Midwest City/Grants Management Division	Weed & Seed Program	\$25,000.00	\$25,000.00		\$0.00	Recipient paid overage \$13,064.00
City of Midwest City/Grants Management Division	Business Incentive Program	\$107,328.76	107,328.76		\$0.00	Recipient paid overage \$198,677.24
City of Midwest City/Neighborhood Services Dept.	Operation Paintbrush	\$10,000.00	\$10,000.00		\$0.00	
City of Midwest City/Neighborhood Services Dept.	Neighborhood Gatherings & Cleanups	\$20,000.00	\$20,000.00		\$0.00	
City of Midwest City/Street Department	Crutcho Creek Nature Trail Bridge	\$25,000.00	\$17,177.77	\$7,822.23	\$0.00	Recipient returned \$7,822.23 to Accounting
Crutcho Public Schools	MWC Waterline Project	\$20,460.85	\$20,460.85		\$0.00	
Del City Chamber of Commerce	Del Quest Program	\$3,400.00	\$3,400.00		\$0.00	Recipient paid overage \$83.26
Holiday Lights Spectacular, Inc.	Displays, Tree Wraps, etc.	\$25,000.00	\$25,000.00		\$0.00	Recipient paid overage \$520.94
Literacy Link	Books, Office Equipment	\$3,040.00	\$3,040.00		\$0.00	Recipient paid overage \$160.06
Mid-Del Schools	Great Expectations Program	\$25,000.00	\$24,424.47	\$575.53	\$0.00	Recipient returned \$575.53 to Accounting
Mid-Del Schools	Stranger Danger Program	\$5,310.00	\$5,310.00		\$0.00	
Mid-Del Youth & Family Center, Inc.	Four (4) Computers	\$2,800.00	\$2,790.40	\$9.60	\$0.00	Recipient returned \$9.60 to Accounting
Midwest City Chamber of Commerce	Youth Excel Program	\$2,000.00	\$2,000.00		\$0.00	Recipient paid overage \$96.16
Midwest City Community Playground Project	Replace Aging Playground Equipment/Regional Park	\$75,000.00	\$75,000.00		\$0.00	Recipient paid overage \$89,524.82
Midwest City Martin Luther King Jr. Prayer Breakfast Committee	Prayer Breakfast	\$5,000.00	\$5,000.00		\$0.00	Recipient paid overage \$2,297.34
Midwest City Martin Luther King Jr. Prayer Breakfast Committee	Workshops	\$3,500.00	\$951.90	\$2,548.10	\$0.00	Recipient returned \$2,548.10 to Accounting
Midwest City Public Art Board	ART Oklahoma 2003	\$3,000.00	\$2,940.22	\$59.78	\$0.00	Recipient returned \$59.78 to Accounting
Midwest City Public Library	Large Print Materials & Shelving	\$3,000.00	\$3,000.00		\$0.00	Recipient paid overage \$3.39
Midwest City Rotary Club	Renovate Rotary Pavilion/Regional Park	\$35,000.00	\$30,211.42	\$4,788.58	\$0.00	Recipient returned \$4,788.58 to Accounting
Tinker Inter-Tribal Council	Establish Annual MWC Pow Wow	\$5,000.00	\$5,000.00		\$0.00	Recipient paid overage \$951.32
	Total Award Amount	\$500,000.00				
	Sub-Totals		\$502,166.95	\$15,803.82	-\$17,970.77	
	Total FY 02-03 Grant Expenditures				\$502,166.95	
	Monies Returned to Hospital Authority Account				\$15,803.82	
	Total FY 02-03 Grant Monies Remaining				-\$17,970.77	
	Totaling				\$500,000.00	

MWC Hospital Authority GRANT RECIPIENTS 2001-02

GRANT RECIPIENT	PURCHASE ITEM	AWARD AMOUNT	EXPENDITURES	MONEY RETURNED	BALANCE	REMARKS
City of Midwest City/EOC	Lightning Protection for 8 Sirens	\$11,385.00	\$22,970.77	\$1,781.00	\$0.00	Recipient returned \$1,781.00 to Accounting 11/02
City of Midwest City/Fire Department	Hazardous Material Training	\$32,191.03	\$32,191.03		\$0.00	Recipient paid overage \$1,594.97
City of Midwest City/John Conrad Golf Course	Modernization of Golf Course	\$10,000.00	\$7,877.13	\$2,122.87	\$0.00	Recipient returned \$2,122.87 to Accounting 7/03
City of Midwest City/MIS	Network/Overhead Projector	\$17,400.00	\$17,400.00		\$0.00	Recipient paid overage \$39.25
City of Midwest City/Neighborhood Services Dept.	Operation Paintbrush	\$7,500.00	\$7,326.74	\$173.26	\$0.00	Recipient returned \$173.26 to Accounting 2/03
City of Midwest City/Neighborhood Services Dept.	Neighborhood Gatherings & Cleanups	\$20,000.00	\$19,917.72	\$82.28	\$0.00	Recipient returned \$82.28 to Accounting 2/03
City of Midwest City/PWA	Fitness Program	\$21,000.00	\$18,361.27	\$2,638.73	\$0.00	Recipient returned \$2,638.73 to Accounting 7/03
Crutcho Public Schools	MWC Water Line Installation	\$12,119.15	\$12,119.15		\$0.00	Recipient paid overage \$20,460.85
Holiday Lights Spectacular, Inc.	Upgrade Electrical System	\$40,000.00	\$40,000.00		\$0.00	Recipient paid overage \$367.00
Holy Family Name/Catholic Charities	Stove Hood & Fence	\$13,527.00	\$13,527.00		\$0.00	Recipient paid overage \$201.00
Literacy Link	Books, Office Equipment	\$2,303.80	\$2,303.80		\$0.00	Recipient paid overage \$36.04
Martin Luther King Jr. Prayer Breakfast Committee	Prayer Breakfast	\$5,000.00	\$5,000.00		\$0.00	Recipient paid overage \$227.07
Mid-Del Group Homes, Inc.	Pallet Jacket	\$500.00	\$381.63	\$118.37	\$0.00	Recipient returned \$118.37 to Accounting 11/02
Mid-Del Group Homes, Inc.	Building Addition	\$50,000.00	\$50,000.00		\$0.00	Recipient paid overage \$25,412.56
Mid-Del Schools	Senior Link Program	\$9,877.00	\$9,224.18	\$652.82	\$0.00	Recipient returned \$652.82 to Accounting 4/04
Mid-Del Schools	Great Expectations Program	\$25,000.00	\$24,944.10	\$55.90	\$0.00	Recipient returned \$55.90 to Accounting 12/03
Mid-Del Youth & Family Center, Inc.	Nit Medical Supplies	\$405.00	\$405.00		\$0.00	Recipient paid overage \$22.29
Mid-Del Youth & Family Center, Inc.	Loss Prevention WIA Youth Dev. Program	\$737.00	\$737.00		\$0.00	Recipient paid overage \$46.37
Mid-Del Youth & Family Center, Inc.	Replace Roof Children's Shelter	\$9,306.46	\$9,306.46		\$0.00	Recipient paid overage \$439.27
Midwest Choral Society, Inc.	2002 Concert Performances	\$1,000.00	\$1,000.00		\$0.00	Recipient paid overage \$4,294.19
Midwest City Chamber of Commerce	Youth Excel	\$2,000.00	\$2,000.00		\$0.00	Recipient paid overage \$447.69
Midwest City Chamber of Commerce	Construct New Facility	\$50,000.00	\$50,000.00		\$0.00	Recipient paid overage \$50,433.50
Midwest City Kiwanis Club	Landscaping Improvements Kiwanis Park	\$9,459.56	\$9,459.56		\$0.00	Recipient paid overage \$224.57
Midwest City Public Art Board	Tents, etc., ARTOklahoma Event	\$9,875.00	\$9,875.00		\$0.00	Recipient paid overage \$231.16
Midwest City Public Library	Signage for Entrances	\$10,015.00	\$8,863.30	\$1,151.70	\$0.00	Recipient returned \$1,151.70 to Accounting 7/03
Midwest City Rotary Club #5750	U.S. Flag Project	\$15,000.00	\$14,664.79	\$335.21	\$0.00	Recipient returned \$335.21 to Accounting 7/03
Mission Mid-Del, Inc.	15-Passenger Van	\$24,000.00	\$24,000.00		\$0.00	Recipient paid overage \$743.00
Retired Senior Volunteer Program Central Oklahoma, Inc.	Blues Program	\$9,600.00	\$9,600.00		\$0.00	Recipient paid overage \$306.33
Studio Mid-Del, Inc.	Construct Facility	\$50,000.00	\$50,000.00		\$0.00	Recipient paid overage \$1,003.00
YWCA of Oklahoma City	SANE Program	\$30,799.00	\$30,799.00		\$0.00	Recipient paid overage \$1,704.08
	Total Award Amount	\$500,000.00				
	Sub-Totals		\$504,254.63	\$9,112.14	\$0.00	
	Total FY 01-02 Grant Expenditures				\$504,254.63	
	Monies Returned to Hospital Authority Account				\$9,112.14	
	Total FY 01-02 Grant Monies Remaining				-\$13,366.77	
	Totaling				\$500,000.00	

MWC Hospital Authority GRANT RECIPIENTS 2000-01

GRANT RECIPIENT	PURCHASE ITEM	AWARD AMOUNT	EXPENDITURES	MONEY RETURNED	BALANCE	REMARKS
Catholic Charities/Holy Family Name	Van	\$10,000.00	\$22,970.77		-\$12,970.77	Recipient paid overage \$10,300.00
Central Oklahoma Habitat for Humanity	Construct 10 homes	\$70,000.00	\$70,000.00		\$0.00	Recipient paid overage \$41,616.23
City of Midwest City/Fire Department	Pulse Oximetry, etc.	\$6,472.50	\$6,465.25	\$7.25	\$0.00	
City of Midwest City/Fire Department	Fire Safety Libraries (10)	\$3,000.00	\$2,999.56	\$0.44	\$0.00	Recipient returned monies to Accounting office 5/01
City of Midwest City/John Conrad Golf Course	Clubhouse Upgrade	\$85,000.00	\$85,000.00		\$0.00	Recipient paid overage \$5,675.00
City of Midwest City/Municipal Golf Course	Gazebos	\$12,900.00	\$12,900.00		\$0.00	
City of Midwest City/Neighborhood Services	Operation Paintbrush	\$7,500.00	7,283.55	\$216.45	\$0.00	Recipient returned monies to Accounting office 2/02
City of Midwest City/Police Department	Audio/Recorders/Equipment for Jail	\$4,092.50	\$4,092.50		\$0.00	
City of Midwest City/Police Department	Camera/Microphone/Equipment for Jail	\$5,218.60	\$5,177.05	\$41.55	\$0.00	Recipient returned monies to Accounting office 8/01
City of Midwest City/Police Department	Mats/Physical Skills Employee Training	\$2,400.00	\$2,148.33	\$251.67	\$0.00	Recipient returned monies to Accounting office 6/01
City of Midwest City/Police Department	Sexual Assault Nurse Examiner (SANE)	\$18,345.00	\$0.00	\$18,345.00	\$0.00	Recipient returned monies to Accounting office 9/01
City of Midwest City/Police Department	Voice Messaging Notification System	\$27,400.00	\$26,816.98	\$583.02	\$0.00	Recipient returned monies to Accounting office 1/02
City of Midwest City/Soldier Creek Nature Trail	South Trail Upgrade w/Hard Surface	\$23,400.00	\$23,400.00		\$0.00	Recipient paid overage \$4,746.99
City of Midwest City/Soldier Creek Nature Trail	Bird Watcher's Lane	\$9,466.76	\$7,613.95	\$1,852.81	\$0.00	Recipient returned monies to Accounting office 8/02
City of Midwest City/Street Department	Tree Spade	\$18,100.00	\$18,100.00		\$0.00	Recipient paid overage \$36.16
Holiday Lights Spectacular, Inc.	Upgrade Electric System	\$25,000.00	\$25,000.00		\$0.00	Recipient paid overage \$7,484.00
Literacy Link	Reading & Writing Materials	\$3,008.04	\$3,008.04		\$0.00	Recipient paid overage \$8.66
Mid-Del Congress of Parents & Teachers	Clothing Room	\$2,000.00	\$2,000.00		\$0.00	Recipient paid overage \$6.38
Mid-Del Group Homes, Inc.	Forklift	\$10,000.00	\$9,804.45	\$195.55	\$0.00	Recipient returned monies to Accounting office 12/01
Mid-Del Schools Academic Center	Outdoor Classroom	\$5,840.00	\$5,840.00		\$0.00	Recipient paid overage \$10.85
Mid-Del Technology Center	Neighborhood Electric Vehicle Demo. Project	\$7,108.00	\$7,108.00		\$0.00	Recipient paid overage \$1,581.00
Mid-Del Youth & Family Center, Inc.	Computer	\$1,457.83	\$1,457.83		\$0.00	Recipient paid overage \$47.30
Mid-Del Youth & Family Center, Inc.	Safe Place Program	\$6,190.53	\$2,840.98	\$3,349.55	\$0.00	Recipient returned \$3,349.55 to Accounting office 4/9/02
Mid-Del Youth & Family Center, Inc.	Curriculum Second Step Program	\$505.00	\$505.00		\$0.00	Recipient paid overage \$132.72
Mid-Del Youth & Family Center, Inc.	Storage Building	\$2,443.18	\$2,418.76	\$24.42	\$0.00	Recipient returned \$24.42 to Accounting office 4/9/02
Mid-Del Youth & Family Center, Inc.	Type and Talk Translator	\$378.26	\$0.00	\$378.26	\$0.00	Recipient returned \$378.26 to Accounting office 4/9/02
Mid-Del Youth & Family Center, Inc.	Prevention Youth Violence Program	\$1,985.00	\$0.00	\$1,985.00	\$0.00	Recipient returned \$1,985.00 to Accounting office 4/9/02
Midwest City High School Museum, Inc.	Museum	\$10,000.00	\$10,000.00		\$0.00	Recipient paid overage \$194.00
Midwest City Tree Board	Irrigation system/Adair Boulevard median	\$38,878.80	\$38,789.95	\$88.85	\$0.00	Recipient returned \$88.85 to Accounting office 4/02
MWC Martin Luther King Jr. Prayer Breakfast Comm.	Prayer Breakfast	\$5,000.00	\$5,000.00		\$0.00	Recipient paid overage \$1,263.45
OK Country Soccer Club	Marquee signs (2), additional seating & benches	\$18,910.00	\$18,910.00		\$0.00	Recipient paid overage \$275.20
Studio Mid-Del, Inc.	Build New Facility	\$50,000.00	\$50,000.00		\$0.00	Building Fund account "seed money"
United Scottish Clans of Oklahoma, Inc.	United Scottish Clans Festival	\$8,000.00	\$8,000.00		\$0.00	Recipient paid overage \$5,698.49
	Total Award Amount	\$500,000.00				
	Sub-Totals		\$485,650.95	\$27,319.82	-\$12,970.77	
	Total FY 00-01 Grant Expenditures				\$485,650.95	
	Monies Returned to Hospital Authority Account				\$27,319.82	
	Total FY 00-01 Grant Monies Remaining				-12,970.77	
	Totaling				\$500,000.00	

MWC HOSPITAL AUTHORITY GRANT RECIPIENTS FY 1999-00

GRANT RECIPIENT	PURCHASE ITEM	AWARD AMOUNT	EXPENDITURES	MONEY RETURNED	BALANCE	REMARKS
Central Okla. Habitat for Humanity	Construct 8 houses	\$56,000.00	\$22,970.77		\$0.00	Recipient paid overage \$17,548.38
City of Midwest City	Irrigation system	\$30,000.00	\$30,000.00		\$0.00	Recipient paid overage \$31,755.00
City of Midwest City/EOC	Replace 8 emergency warning sirens	\$58,440.00	\$58,440.00		\$0.00	Recipient paid overage \$44,260.90
City of Midwest City/Fire Department	Directional Arrow Bar	\$7,456.00	\$7,448.71	\$7.29	\$0.00	Recipient returned \$7.29 to accounting office 2/01
City of Midwest City/Holiday Lights Spectacular	Holiday Display	\$791.27	\$791.27		\$0.00	Recipient paid overage \$7,335.73
City of Midwest City/Holiday Lights Spectacular	Storage Building	\$40,000.00	\$40,000.00		\$0.00	Recipient paid overage \$2,050.00
City of Midwest City/MIS Department	WAN/LAN Computer Interface	\$48,000.00	\$43,833.74	\$4,166.26	\$0.00	Recipient returned monies to accounting office 11/01
City of Midwest City/Parks & Recreation	Pavilion/restroom Project	\$99,310.00	\$99,310.00		\$0.00	Recipient paid overage \$359.20
City of Midwest City/Police Department	12 sets Turbo Flares	\$5,548.20	\$5,548.20		\$0.00	
City of Midwest City/Soldier Creek Nature Trail	Present Trail enhancements	\$40,750.00	\$40,750.00		\$0.00	Recipient paid overage \$11,215.78
Literacy Link	Reading & writing materials	\$2,446.53	\$2,446.53		\$0.00	Recipient paid overage \$4.15
Mid-Del Group Homes	Van	\$12,500.00	\$12,500.00		\$0.00	Recipient paid overage \$13,529.60
Mid-Del Public Schools Foundation, Inc.	Biology/Math project	\$4,500.00	\$4,500.00		\$0.00	Recipient paid overage \$27.72
Mid-Del Youth & Family Center, Inc.	Replace 3 sofas Children's Shelter	\$600.00	\$600.00		\$0.00	
Mid-Del Youth & Family Center, Inc.	Replace various appliances Childrens Shelter	\$4,553.00	\$4,553.00		\$0.00	
Mid-Del Youth & Family Center, Inc.	Network/juvenile offenders	\$6,605.00	\$6,605.00		\$0.00	
Midwest City Amateur Athletic Assoc.	Boxing facility	\$48,000.00	\$0.00	\$48,000.00	\$0.00	Recipient returned check to accounting office 7/00
Midwest City Chamber of Commerce	Business/Industrial Park	\$25,000.00	\$0.00	\$25,000.00	\$0.00	Recipient returned monies to accounting office 2/01
Midwest City Chamber of Commerce	Youth Excel Program	\$1,500.00	\$1,500.00		\$0.00	Recipient paid overage \$19.15
United Scottish Clans of Oklahoma	United Scottish Clans Festival	\$8,000.00	\$8,000.00		\$0.00	Recipient paid overage \$11,061.73
	Total Award Amount	\$500,000.00				
	Sub-Totals		\$389,797.22	\$77,173.55	\$0.00	
	Total FY 99-00 Grant Expenditures				\$389,797.22	
	Monies Returned to Hospital Authority Account				\$77,173.55	
	Total FY 99-00 Grant Monies Remaining				33,029.23	
	Totaling				\$500,000.00	

MWC Hospital Authority GRANT RECIPIENTS 1998-99

GRANT RECIPIENT	PURCHASE ITEM	AWARD AMOUNT	EXPENDITURES	MONEY RETURNED	BALANCE	REMARKS
MWC	Downtown Development	\$50,000.00	\$22,970.77		\$0.00	Recipient paid overage \$45.80
MWC Fire Department	Projector	\$7,281.00	\$7,487.82		\$0.00	\$206.82} Combined balances 2 grants = \$411.19 returned to accounting 8/00
MWC Fire Department	Infrarad Camera	\$20,805.00	\$20,186.99	\$411.19	\$0.00	-\$618.01}
MWC John Conrad Golf Course	Irrigation System	\$55,000.00	\$55,000.00		\$0.00	Recipient paid overage \$25,213.64
MWC Municipal Golf Course	Fencing, Carpet	\$19,020.00	\$19,020.00		\$0.00	Recipient paid overage \$2,887.67
MWC Soldier Creek	Nature Trail	\$28,103.00	\$23,986.08	\$4,116.92	\$0.00	\$4,116.92 balance returned to accounting 8/00
Holiday Lights Spectacular	Light Display	\$15,000.00	\$15,000.00		\$0.00	Recipient paid overage \$1,148.56
MWC Senior Advisory Committee	Van	\$40,000.00	\$40,000.00		\$0.00	Recipient paid overage \$1,289.00
Associated Catholic Charities	Holy Family Home	\$25,000.00	\$25,000.00		\$0.00	Recipient paid overage \$25,491.11
Autumn House	Van	\$26,452.00	\$26,452.00		\$0.00	Recipient paid overage \$21,447.78
Carl Albert High School	Visual Arts Equipment	\$1,536.00	\$1,536.00		\$0.00	Recipient paid overage \$32.00
Central Oklahoma Habitat for Humanity	Homes built in MWC	\$20,000.00	\$20,000.00		\$0.00	Recipient paid overage \$24,861.40
Communication Connection "Dog Ears"	2 Dogs & Training for Hearing Impaired	\$6,800.00	\$5,894.16	\$905.84	\$0.00	*\$905.84 balance returned to accounting 7/31/00
Literacy Link	Printer, educational material (books)	\$3,658.00	\$3,658.00		\$0.00	Recipient paid overage \$0.18
Mid-Del PTA Council	Clothing	\$2,000.00	\$2,000.00		\$0.00	Recipient paid overage \$762.58
Mid-Del Schools	Youth/Senior Citizens	\$12,894.00	\$12,894.00		\$0.00	Recipient paid overage \$567.40
Mid-Del Youth & Family	Carpet, etc.	\$7,950.00	\$7,950.00		\$0.00	\$1,167.37
Mid-Del Youth & Family	Storm Shelter	\$4,600.00	\$4,600.00		\$0.00	\$730.00/Combined balances 3 grants = \$959.63/Recipient paid overage
Mid-Del Youth & Family	Building Renovation	\$11,605.00	\$11,605.00		\$0.00	-\$2,857.00
Midwest City Choral Society	Musicians, etc.	\$3,800.00	\$3,800.00		\$0.00	Recipient paid overage \$6.29
MWC MLKing Jr. Prayer Breakfast Committee	Prayer Breakfast	\$4,000.00	\$4,000.00		\$0.00	Recipient paid overage \$726.68
OMNI Neighborhood Assoc.	Playground	\$10,000.00	\$9,926.63	\$73.37	\$0.00	\$73.37 balance remaining returned to accounting 7/10/00
Optimist Club	Park	\$10,000.00	\$10,000.00		\$0.00	Recipient paid overage \$6,250.00
United Scottish Clans of Oklahoma	Festival	\$7,000.00	\$7,000.00		\$0.00	Recipient paid overage \$116.48
	Total Award Amount	\$392,504.00				
	Sub-Totals		\$359,967.45	\$5,507.32	\$0.00	
	Total FY 98-99 Grant Expenditure				\$359,967.45	
	Monies Returned to Hospital Authority Account				\$5,507.32	
	Total FY 98-99 Grant Monies Remaining				\$0.00	
	Totaling				\$365,474.77	

FISCAL YEAR 2018-19 GRANT RECIPIENT AGREEMENT

This Agreement is made and entered into by and between the Midwest City Memorial Hospital Authority, a public trust (the "Authority"), and _____("Grant Recipient").

The purpose of this Agreement is for the parties to establish the terms and conditions under which the Authority makes a grant of funds to the Grant Recipient and the Grant Recipient performs the public function project in the manner described in the application that the Grant Recipient filed with the Authority, a copy of which is attached to and incorporated by reference in this Agreement, further subject to conditions that may be imposed by the Authority (collectively, the "Grant Requirements").

In consideration of the Authority's payment of grant funds to the Grant Recipient in the amount of \$_____ for the public function project described by the Grant Requirements, the Grant Recipient agrees to the following terms and conditions:

1. The term of this Agreement shall be for a period of one (1) year, except with respect to Grant Property as provided for by section 5 below. Grant Recipient must spend the grant funds for the public function project described by the Grant Requirements, which must be used during the one-year term of this Agreement. Receipts and/or other acceptable proof evidencing the expenditure of the grant funds must be submitted to the General Manager within thirty (30) days of each expenditure,
2. If the Grant Recipient is unable to spend the grant funds for the public function project in the described manner within the one-year period, the remaining balance of the grant funds must be returned to the Authority or a six-month extension must be requested to the Authority through the General Manager/Administrator of the Authority in writing at ghenson@midwestcityok.org or by mail to Guy Henson, General Manager/Administrator at 100 N. Midwest Boulevard, Midwest City, OK 73110.
3. Grant Recipient is encouraged, but not required, to spend grant funds in Midwest City. The Grant Recipient is urged to purchase commodities needed for its public function project from a Midwest City vendor if possible and practicable.
4. At the conclusion of the project, the Grant Recipient agrees to reflectively complete the Grant Outcome Report describing the process and outcome of the grant-funded project and submit appropriate photographs, newspaper clippings, etc.
5. If grant funds are used to purchase furnishings, equipment or other property ("Grant Property"), such must have a useful life of 20-years and must be used by the Grant Recipient in accordance with the Grant Requirements throughout the 20-year life of the Grant Property. If the Grant Property ceases to be used in accordance with the Grant Requirements during such 20-year period, the Grant Recipient shall within 30 calendar days provide written notice to the General Manager/Administrator, in which case the Authority may, at its election, take possession of the

Grant Property, and in such case, the ownership of the Property shall be transfer to the Authority, with the Grant Recipient providing such bills of sale and other evidence of transfer of ownership as requested by Authority. The term of this Agreement shall be 20-years with respect to Grant Property. The provisions of this Section 5 shall have a term of 20-years.

6. It is understood and agreed that this grant is made and shall be administered and carried out in accordance with the provisions and requirements of the Trust Indenture of the Authority, the Operating Contract between the Trust Board of Grantors and the Authority, the Bylaws of the Trust Board of Grantors and the Policies and Procedures of the Authority and the Trust Board of Grantors, each as may be amended from time to time.

This Agreement is approved and executed by the Authority on the _____ day of _____, 2019, and by the Grant Recipient on the _____ day of _____, 2019.

Signature of Grant Recipient

Grant Recipient Name

Grant Recipient Address

Tax ID No. _____

ATTEST:

Midwest City Memorial Hospital Authority

Sara Hancock, Secretary

Matthew D. Dukes, II, Chairman

~~Fiscal Year~~

FISCAL YEAR 2018-19 GRANT RECIPIENT AGREEMENT

This Agreement is made and entered into by and between the Midwest City Memorial Hospital Authority, a public trust (the "Authority"), and _____ ("Grant Recipient").

The purpose of this Agreement is for the parties to establish the terms and conditions under which the Authority makes a grant of funds to the Grant Recipient and the Grant Recipient performs the public function project in the manner described in the application that the Grant Recipient filed with the Authority, a copy of which is attached to and incorporated by reference in this Agreement, further subject to conditions that may be imposed by the Authority (collectively, the "Grant Requirements").

In consideration of the Authority's payment of grant funds to the Grant Recipient in the amount of \$_____ for the public function project described ~~in by the attached application~~ Grant Requirements, the Grant Recipient agrees to the following terms and conditions:

1. The term of this Agreement shall be for a period of one (1) year, except with respect to Grant Property as provide for by section 5 below. Grant Recipient must spend the grant funds for the public function project described ~~in by the application, and grant funds~~ Grant Requirements, which must be used ~~in the manner described in the grant application~~ during the one-year term of this Agreement. - Receipts and/or other acceptable proof evidencing the expenditure of the grant funds must be submitted to the General Manager within thirty (30) days of each expenditure.
2. If the Grant Recipient is unable to spend the grant funds for the public function project in the described manner within the one-year period, the remaining balance of the grant funds must be returned to the Authority or a six-month extension must be requested to the Authority through the General Manager/Administrator of the Authority in writing at ghenson@midwestcityok.org or by mail to Guy Henson, General Manager/Administrator at 100 N. Midwest Boulevard, Midwest City, OK 73110.
3. Grant Recipient is encouraged, but not required, to spend grant funds in Midwest City. -The Grant Recipient is urged to purchase commodities needed for its public function project from a Midwest City vendor if possible and practicable.
4. At the conclusion of the project, the Grant Recipient agrees to reflectively complete the Grant Outcome Report describing the process and outcome of the grant-funded project and submit appropriate photographs, newspaper clippings, etc.
5. If grant funds are used to purchase furnishings, equipment or other property ("Grant Property"), such must have a useful life of 20-years and must be used by the Grant Recipient in accordance with the Grant Requirements throughout the 20-year life of the Grant Property. If the Grant Property ceases to be used in accordance with the Grant Requirements during such 20-year period, the Grant Recipient shall within 30 calendar days provide written notice to the General Manager/Administrator, in which case the Authority may, at its election, take possession of the

Grant Property, and in such case, the ownership of the Property shall be transfer to the Authority, with the Grant Recipient providing such bills of sale and other evidence of transfer of ownership as requested by Authority. The term of this Agreement shall be 20-years with respect to Grant Property. The provisions of this Section 5 shall have a term of 20-years.

6. It is understood and agreed that this grant is made and shall be administered and carried out in accordance with the provisions and requirements of the Trust Indenture of the Authority, the Operating Contract between the Trust Board of Grantors and the Authority, the Bylaws of the Trust Board of Grantors and the Policies and Procedures of the Authority and the Trust Board of Grantors, each as may be amended from time to time.

This Agreement is approved and executed by the Authority on the _____ day of _____, 2019, and by the Grant Recipient on the _____ day of _____, 2019.

Signature of Grant Recipient

Grant Recipient Name

Grant Recipient Address

Tax ID No. _____

ATTEST:

Midwest City Memorial Hospital Authority

Sara Hancock, Secretary

Matthew D. Dukes, II, Chairman



MIDWEST CITY SPECIAL ECONOMIC DEVELOPMENT AUTHORITY AGENDA

- ♥ The 7:00 PM meetings will be shown live on Channel 20.
- ♥ The recorded video will be available on Youtube and the City's website within 48 hours at www.youtube@midwestcityok.org.
- ♥ The meeting minutes and video can be found on the City's website in the Agenda Center: <https://midwestcityok.org/AgendaCenter>.
- ♥ To make a special assistance request, call 739-1215 or email pmenefee@midwestcityok.org no less than 24 hours prior to the start of a meeting. If special assistance is needed during a meeting, call 739-1388.



MIDWEST CITY SPECIAL ECONOMIC DEVELOPMENT AUTHORITY AGENDA

City Hall - Midwest City Council Chambers, 100 N. Midwest Boulevard

February 12, 2019 - 6:03 PM

- A. CALL TO ORDER.
- B. CONSENT AGENDA. These items are placed on the Consent Agenda so that Trustees, by unanimous consent, can approve routine agenda items by one motion. If any item proposed does not meet with approval of all Trustees, or members of the audience wish to discuss an item, it will be removed and heard in regular order.
1. Discussion and consideration of approving the minutes of the special meeting of January 22, 2019, as submitted. (City Clerk - S. Hancock)
 2. Discussion and consideration of approving and entering into an engagement letter with Grant Thornton, LLP to perform GAAP audits for the calendar year ending December 31, 2018 for Sooner Town Center (STC), LLC and STC Lowe's, LLC in an amount not to exceed \$45,200 in audit fees plus \$3,164 in administrative fees and authorizing the city manager to act on behalf of the Authority during the audit to provide information, oversee the audit process and make determinations as required. (Finance – C. Barron)
- C. NEW BUSINESS/PUBLIC DISCUSSION. The purpose of the "Public Discussion Section" of the Agenda is for members of the public to speak to the Authority on any Subject not scheduled on the Regular Agenda. The Authority shall make no decision or take any action, except to direct the City Manager to take action, or to schedule the matter for discussion at a later date. Pursuant to the Oklahoma Open Meeting Act, the Authority will not engage in any discussion on the matter until that matter has been placed on an agenda for discussion. **THOSE ADDRESSING THE AUTHORITY ARE REQUESTED TO STATE THEIR NAME AND ADDRESS PRIOR TO SPEAKING TO THE AUTHORITY.**
- D. EXECUTIVE SESSION .
1. Discussion and consideration of 1) entering into executive session, as allowed under 25 O.S. § 307(B)(3), to discuss the purchase or appraisal of real property; and 2) in open session, authorizing the general manager/ administrator to take action as appropriate based on the discussion in executive session. (Economic Development - R. Coleman)
 2. Discussion and consideration of 1) entering into executive session, as allowed under 25 O.S. § 307(C)(10), to confer on matters pertaining to economic development, including the transfer of property, financing or the creation of a proposal to entice a business to remain or to locate within the City; and 2) in open session, authorizing the city manager to take action as appropriate based on the discussion in executive session. (Economic Development - R. Coleman)
- E. ADJOURNMENT.



CONSENT AGENDA



A notice for this special Midwest City Economic Development Authority meeting was filed with the City Clerk of Midwest City 48 hours prior to the meeting. Public notice of this agenda was accessible at least 24 hours before this meeting at City Hall and on the Midwest City website (www.midwestcityok.org).

Special Midwest City Economic Development Authority Meeting Minutes

January 22, 2019 – 6:04 PM

This meeting was held in the Midwest City Council Chambers, in City Hall, 100 N. Midwest Boulevard, Midwest City, County of Oklahoma, State of Oklahoma.

Chairman Matt Dukes called the meeting to order at 6:49 PM with the following members present: Trustees: Susan Eads, Española Bowen, Sean Reed, and Christine Allen; and Secretary Sara Hancock, City Attorney Heather Poole, and Acting City Manager Tim Lyon. Absent: Pat Byrne and Jeff Moore.

DISCUSSION ITEM.

1. **Discussion and consideration of approving the minutes of the staff briefing, and special meeting of November 13, 2018, as submitted.** Allen made a motion to approve the minutes, as submitted, seconded by Bowen. Voting aye: Eads, Bowen, Reed, Allen, and Chairman Dukes. Nay: none. Absent: Byrne and Moore. Motion carried.

NEW BUSINESS/PUBLIC DISCUSSION. There was no new business or public discussion.

EXECUTIVE SESSION.

1. **Discussion and consideration of 1) entering into executive session, as allowed under 25 O.S. § 307(B)(3), to discuss the purchase or appraisal of real property; and 2) in open session, authorizing the general manager/administrator to take action as appropriate based on the discussion in executive session.** No executive session was needed.

ADJOURNMENT.

There being no further business, Chairman Dukes adjourned the meeting at 6:50 PM.

ATTEST:

MATTHEW D. DUKES II, CHAIRMAN

SARA HANCOCK, Secretary



City Manager
100 N. Midwest Boulevard
Midwest City, OK 73110
office 405.739.1204

MEMORANDUM

TO: Economic Development Authority Board Members

FROM: Tim Lyon, Acting City Manager

DATE: February 12, 2019

SUBJECT: Discussion and consideration of approving and entering into an engagement letter with Grant Thornton, LLP to perform GAAP audits for the calendar year ending December 31, 2018 for Sooner Town Center (STC), LLC and STC Lowe's, LLC in an amount not to exceed \$45,200 in audit fees plus \$3,164 in administrative fees and authorizing the city manager to act on behalf of the Authority during the audit to provide information, oversee the audit process and make determinations as required.

Attached for your review and approval is an agreement with Grant Thornton, LLP, Charlotte, NC, to provide the required audit for property associated with the Downtown Redevelopment project. STC III (Old Navy and Versona) has been combined with STC, LLC and STC Lowe's, LLC when we issued the 2018 revenue bonds in February, 2018 to provide refinancing to Sooner Investment.

The costs of the audit is borne by the LLC. Approval of the engagement letter allows the Authority to be a participant in the audit process and allows the Authority to review audit working papers and related documents.

Staff recommends approval.

Tim Lyon
Acting City Manager



January 7, 2019

Mr. Robert C. Collett
Managing Member
Sooner Town Center, LLC and STC Lowe's LLC
1111 Metropolitan Avenue, #700
Charlotte, NC 28204

Grant Thornton LLP
201 S. College Street
Suite 2500
Charlotte, NC 28244

T 704.632.3500
F 704.334.7701
www.GrantThornton.com

Katherine Fox
Chief Financial Officer
Sooner Town Center, LLC and STC Lowe's LLC
1111 Metropolitan Avenue, #700
Charlotte, NC 28204

Mr. Matthew Dukes II
Chairman
Midwest City Economic Development Authority
100 N Midwest City Blvd
Midwest City, OK 73110

Dear Mr. Collett, Ms. Fox, and Mr. Dukes:

Thank you for discussing with us the requirements of our forthcoming engagement. This letter (the "Engagement Letter") documents our mutual understanding of the arrangements for the services described herein.

Scope of services

Grant Thornton LLP ("Grant Thornton") will audit the combined consolidated balance sheet of Sooner Town Center, LLC and STC Lowe's LLC (the "Company") as of December 31, 2018, and the related combined statements of operations, members' deficit, and cash flows for the year then ended.

Our audit will be conducted in accordance with auditing standards generally accepted in the United States of America ("US GAAS") established by the American Institute of Certified Public Accountants ("AICPA"). An audit involves performing procedures to obtain audit evidence about the amounts and disclosures in the financial statements. The procedures selected depend on the auditor's judgment, including the assessment of the risks of material misstatement of the financial statements, whether due to fraud or error. An audit also includes evaluating the appropriateness of accounting policies used and the reasonableness of significant accounting estimates made by management, as well as evaluating the overall financial statement presentation.

In assessing the risks of material misstatement, an auditor considers internal control relevant to the company's preparation and fair presentation of the financial statements in order to design

audit procedures that are appropriate in the circumstances. An audit is not designed to identify control deficiencies or for the purpose of expressing an opinion on internal control; accordingly, we will not express such an opinion. However, we are responsible for communicating to you (hereinafter referred to as “those charged with governance”) significant deficiencies and material weaknesses in internal control that come to our attention during the course of our engagement.

When conducting an audit, the auditor is required to obtain reasonable assurance about whether the financial statements are free from material misstatement, whether caused by error or fraud, to enable the auditor to express an opinion on whether the financial statements are presented fairly, in all material respects, in accordance with accounting principles generally accepted in the United States of America. Although not absolute assurance, reasonable assurance is, nevertheless, a high level of assurance. However, an audit is not a guarantee of the accuracy of the financial statements. Even though the audit is properly planned and performed in accordance with professional standards, an unavoidable risk exists that some material misstatements may not be detected due to the inherent limitations of an audit, together with the inherent limitations of internal control. Also, an audit is not designed to detect errors or fraud that is immaterial to the financial statements.

Upon the completion of the foregoing audit and subject to its findings, we will render our report and communicate our findings in accordance with US GAAS. However, it is possible that circumstances may arise in which our report may differ from its expected form and content, resulting in a modified report or disclaimer of opinion. Further, if in our professional judgment the circumstances necessitate, we may resign from the engagement prior to completion.

Our audit does not relieve management or those charged with governance of their responsibilities.

Responsibilities of those charged with governance

Effective two-way communication with those charged with governance assists us in obtaining information relevant to the audit and also assists those charged with governance in fulfilling their responsibility to oversee the financial reporting process. Those charged with governance play an important role in the Company’s internal control over financial reporting by setting a positive tone at the top and challenging the Company’s activities in the financial arena. Accordingly, it is important for those charged with governance to communicate to us matters they believe are relevant to our engagement. As indicated below, management also has a responsibility to communicate certain matters to those charged with governance and to Grant Thornton.

In connection with our engagement, professional standards require us to communicate certain matters that come to our attention to those charged with governance, such as the following:

- fraud involving senior management and fraud that causes a material misstatement
- illegal acts, unless clearly inconsequential

- disagreements with management and other serious difficulties encountered
- qualitative aspects of significant accounting practices, including accounting policies, estimates, and disclosures
- audit adjustments and uncorrected misstatements, including missing disclosures.

Management responsibilities

As you are aware, the financial statements are the responsibility of management. Management is responsible for preparing and fairly presenting the financial statements in accordance with accounting principles generally accepted in the United States of America, which includes adopting sound accounting practices and complying with changes in accounting principles and related guidance. Management is also responsible for:

- providing us with access to all information of which they are aware that is relevant to the preparation and fair presentation of the financial statements, including all financial records, documentation of internal control and related information, and any additional information that we may request for audit purposes
- providing us with unrestricted access to persons within the Company from whom we determine it necessary to obtain audit evidence
- ensuring that the Company identifies and complies with all laws, regulations, contracts, and grants applicable to its activities and for informing us of any known violations
- designing, implementing, and maintaining internal control to enable the preparation and fair presentation of financial statements that are free of material misstatement, whether due to error or fraud, and for informing us of all known significant deficiencies and material weaknesses in, and significant changes in, such internal control
- informing us of their views about the risk of fraud within the Company and their awareness of any known or suspected fraud and the related corrective action proposed
- adjusting the financial statements, including disclosures, to correct material misstatements and for affirming to us in a representation letter that the effects of any uncorrected misstatements, including missing disclosures, aggregated by us during the current engagement, including those pertaining to the latest period presented, are immaterial, both individually and in the aggregate, to the financial statements as a whole
- informing us of any events occurring subsequent to the balance sheet date through the date of our auditor's report that may affect the financial statements or the related disclosures
- informing us of any subsequent discovery of facts that may have existed at the date of our auditor's report that may have affected the financial statements or the related disclosures.

To assist those charged with governance in fulfilling their responsibility to oversee the financial reporting process, management should discuss with those charged with governance the:

- adequacy of internal control and the identification of any significant deficiencies or material weaknesses, including the related corrective action proposed
- significant accounting policies, alternative treatments, and the reasons for the initial selection of, or change in, significant accounting policies
- process used by management in formulating particularly sensitive accounting judgments and estimates and whether the possibility exists that future events affecting these estimates may differ markedly from current judgments
- basis used by management in determining that uncorrected misstatements, including missing disclosures, are immaterial, both individually and in the aggregate, including whether any of these uncorrected misstatements could potentially cause future financial statements to be materially misstated.

We will require management's cooperation to complete our services. In addition, we will obtain, in accordance with professional standards, certain written representations from management, which we will rely upon.

Use of our report(s)

The inclusion, publication, or reproduction by the Company of our report(s) in documents such as private placement memoranda and regulatory filings containing information in addition to financial statements may require us to perform additional procedures to fulfill our professional or legal responsibilities. Accordingly, our report(s) should not be used for any such purposes without our prior permission. To avoid unnecessary delay or misunderstanding, it is important that the Company give us timely notice of its intention to issue any such document.

Other services

Supplementary information

Management is responsible for separately preparing the combined balance sheet and statement of operations, and other supplementary schedules including net operating income, debt service, net cash flow, and subtenant rents in accordance with SAS 11, *Supplementary Information in Relation to the Financial Statements as a Whole* (the "applicable criteria"). The supplementary schedules of net operating income, debt service, net cash flow, and subtenant rents will be prepared in compliance with the terms defined in the governing lease agreement with Midwest City, Oklahoma (the "Agreement"). Such supplementary information, which will be presented for purposes of additional analysis and is not a required part of the financial statements, will be subjected to the auditing procedures applied in the audit of the financial statements and certain additional procedures. These procedures will include comparing and reconciling the supplementary information directly to the underlying accounting and other records used to prepare the financial statements or to the financial statements themselves, and other additional procedures in accordance with US GAAS. The purpose of our procedures will be to form and express an opinion as to whether the supplementary information is fairly stated, in all material respects, in relation to the financial statements as a whole.

In connection with our procedures, management is responsible for informing us about:

- the methods of measurement and presentation of the supplementary information
- whether those methods have changed from the methods used in the prior period and the reasons for the change, if any
- any significant assumptions or interpretations underlying the measurement or presentation of the supplementary information.

Management will present the supplementary information with the audited financial statements. Management is responsible for including our report on the supplementary information in any document that contains the supplementary information and that indicates we reported on it.

We will require management to provide us with certain written representations related to their responsibilities described above, including whether management believes the supplementary information (including its form and content) is fairly presented in accordance with the applicable criteria.

Related non-audit services

We will also perform certain bookkeeping services for the Company. The objective of such services will be to draft the Company's financial statements based on information in the trial balance and other information to be provided to us that is approved by you.

As mentioned previously, the financial statements, including the data and information set forth therein, are the responsibility of management. With respect to our bookkeeping services, however, management is also responsible for:

- making all management decisions and performing all management functions
- designating an individual who possesses suitable skills, knowledge, or experience, preferably within senior management, to oversee the services
- evaluating the adequacy and the results of the services performed
- accepting responsibility for the results of the services.

Accordingly, our bookkeeping services will not include management functions or making management decisions. However, we may provide advice, research materials, and recommendations to assist you in performing your responsibilities.

Other services

Any other services that you request will constitute a separate engagement that will be subject to our acceptance procedures.

Fees

Standard billings

Our billings for the services set forth in this Engagement Letter, which we have estimated will total \$45,200 and are payable within 20 days of receipt.

In addition, we will bill for our expenses, including an administrative charge of seven percent of fees to cover items such as copies, postage, supplies, computer and technology usage, software licensing, research and library databases, and similar expense items.

If it appears that the estimated fee will be exceeded, we will bring this to your attention.

From time to time, Grant Thornton may receive certain incentives in the form of bonuses and rewards from its corporate card and other vendors. Such incentives to the extent received will be retained by Grant Thornton to cover firm expenses.

Additional billings

Of course, circumstances may arise that will require us to do more work. Some of the more common circumstances include changing auditing, accounting, and reporting requirements from professional and regulatory bodies; incorrect accounting applications or errors in Company records; restatements; failure to furnish accurate and complete information to us on a timely basis; and unforeseen events, including legal and regulatory changes.

At Grant Thornton, we pride ourselves on our ability to provide outstanding service and meet our clients' deadlines. To help accomplish this goal, we work hard to have the right professionals available. This involves complex scheduling models to balance the needs of our clients and the utilization of our people, particularly during peak periods of the year. Last minute client requested scheduling changes result in costly downtime due to our inability to make alternate arrangements for our professional staff.

We will coordinate a convenient time for Grant Thornton to begin work. If, after scheduling our work, you do not provide proper notice, which we consider to be one week, of your inability to meet the agreed-upon date(s) for any reason, or do not provide us with sufficient information required to complete the work in a timely manner, additional billings will be rendered for any downtime of our professional staff.

Adoption of new revenue and leasing standards

ASC 606, *Revenue from Contracts with Customers*, is effective for non-public business entities for annual reporting periods beginning after December 15, 2018. ASC 842, *Leases*, is effective for non-public business entities for annual reporting periods beginning after December 15, 2019.

We will communicate with management and those charged with governance periodically to understand the Company's ASC 606 or ASC 842 adoption and implementation plan and the progress in executing that implementation plan. As the Company executes on its

implementation plan and identifies necessary changes to systems, processes, and policies, we will request meetings and review documentation related to those expected changes.

Any work we perform related to your ASC 606 or ASC 842 implementation is not included in the scope of work for the audit services outlined in this Engagement Letter. We will discuss with you the fees for the ASC 606 or ASC 842 implementation work. Those fees will be at higher rates than those utilized in the standard audit rates discussed above.

Adoption of other new accounting standards

Professional and regulatory bodies frequently issue new accounting standards and guidance. Sometimes, standards are issued and become effective in the same period, providing a limited implementation phase and preventing us from including the impact in our estimated fees. In such circumstances, we will discuss with you the additional audit procedures and related fees, including matters such as the retrospective application of accounting changes and changes in classification.

Other costs

Except with respect to a dispute or litigation between Grant Thornton and the Company, our costs and time spent in legal and regulatory matters or proceedings arising from our engagement, such as subpoenas, testimony, or consultation involving private litigation, arbitration, industry, or government regulatory inquiries, whether made at the Company's request or by subpoena, will be billed to the Company separately.

Professional standards impose additional responsibilities regarding the reporting of illegal acts that have or may have occurred. To fulfill our responsibilities, we may need to consult with Company counsel or counsel of our choosing about any illegal acts that we become aware of. Additional fees, including legal fees, will be billed to the Company. The Company agrees to ensure full cooperation with any procedures that we may deem necessary to perform.

Right to terminate services for nonpayment

In the event of nonpayment, we retain the right to (a) suspend the performance of our services, (b) change the payment conditions under this Engagement Letter, or (c) terminate our services. If we elect to suspend our services, such services will not be resumed until your account is paid as agreed. Alternatively, if we elect to terminate our services for nonpayment, the Company will be obligated to compensate us for all time expended and to reimburse us for all expenses through the date of termination.

Other matters

Relationship to Grant Thornton International Ltd

Grant Thornton is the U.S. member firm of Grant Thornton International Ltd ("GTIL"), an organization of independently owned and managed accounting and consulting firms. References to GTIL are to Grant Thornton International Ltd. GTIL and the member firms are not a worldwide partnership. Services are delivered independently by the member firms. These firms are not members of one international partnership or otherwise legal partners with each

other internationally, nor is any one firm responsible for the services or activities of any other firm.

Use of third-party service providers and affiliates

Grant Thornton may use third-party service providers, such as independent contractors, specialists, or vendors, to assist in providing our professional services. We may also use GTIL member firms, other affiliates (including the GT US Shared Services Center India Private Limited and the Grant Thornton US Knowledge and Capability Center India Private Limited, affiliates of Grant Thornton located in Bangalore, India), or other accounting firms. Such entities may be located within or outside the United States.

Grant Thornton intends to use the professional services, technology, and resources of the following entity to assist us in the performance of the engagement:

- Capital Confirmation, Inc. – electronic confirmation services
214 Centerview Drive, Suite 265
Brentwood, TN 37027
888-716-3577

Additionally, Grant Thornton may use third-party service providers to provide administrative or operational support to Grant Thornton, or to provide engagement team resource services. Such entities may be located within or outside the United States. All of these third party service providers are subject to confidentiality obligations to protect the confidentiality of client data.

You hereby consent and authorize us to disclose Company information to the GT US Shared Services Center India Private Limited and/or the Grant Thornton US Knowledge and Capability Center India Private Limited and the other above named entity for purposes of providing services to you as part of our professional relationship.

Privacy

Grant Thornton is committed to protecting personal information and will maintain such information in confidence in accordance with professional standards and governing laws. The Company will not provide any personal information to Grant Thornton unless necessary to perform the services described herein. When providing any personal information to us, the Company will comply with all applicable laws (both foreign and domestic) and will anonymize, mask, obfuscate, and/or de-identify, if reasonably possible, all personal information that is not necessary to perform the services described herein. Any personal information provided to us by the Company will be kept confidential and not disclosed to any third party unless expressly permitted by the Company or required by law, regulation, legal process, or professional standards. The Company is responsible for obtaining, pursuant to law or regulation, consents from parties that provided the Company with their personal information, which will be obtained, used, and disclosed by Grant Thornton for its required purposes.

Documentation

The documentation for this engagement is the property of Grant Thornton and constitutes confidential information. We have a responsibility to retain the documentation for a period of time sufficient to satisfy any applicable legal or regulatory requirements for records retention.

Pursuant to law or regulation, we may be requested to make certain documentation available to regulators, governmental agencies, or their representatives (“Regulators”). If requested, access to the documentation will be provided to the Regulators under our supervision. We may also provide copies of selected documentation, which the Regulators may distribute to other governmental agencies or third parties. You hereby acknowledge we will allow and authorize us to allow the Regulators access to, and copies of, the documentation in this manner.

Electronic communications

During the course of our engagement, we may need to electronically transmit confidential information to each other and to third-party service providers or other entities engaged by either Grant Thornton or the Company. Electronic methods include telephones, cell phones, e-mail, secure file transfers, use of SharePoint sites, and fax. These technologies provide a fast and convenient way to communicate. However, all forms of electronic communication have inherent security weaknesses, and the risk of compromised confidentiality cannot be eliminated. The Company agrees to the use of electronic methods to transmit and receive information, including confidential information.

Standards of performance

We will perform our services in conformity with the terms expressly set forth in this Engagement Letter, including all applicable professional standards. Accordingly, our services shall be evaluated solely on our substantial conformance with such terms and standards. Any claim of nonconformance must be clearly and convincingly shown.

With respect to the services and this Engagement Letter, in no event shall the liability of Grant Thornton and its present, future, and former partners, principals, directors, employees, agents, and contractors for any claim, including but not limited to Grant Thornton’s own negligence, exceed the fees it receives for the portion of the work giving rise to such liability. This limitation shall not apply to the extent that it is finally determined that any claims, losses, or damages are the result of Grant Thornton’s gross negligence or willful misconduct. In addition, Grant Thornton shall not be liable for any special, consequential, incidental, or exemplary damages or loss (nor any lost profits, interest, taxes, penalties, loss of savings, or lost business opportunity) even if Grant Thornton was advised in advance of such potential damages. This paragraph and the paragraph directly below shall apply to any type of claim asserted, including contract, statute, tort, or strict liability, whether by the Company, Grant Thornton, or others.

Further, the Company shall, upon receipt of written notice, indemnify and hold harmless Grant Thornton and its present, future, and former partners, principals, directors, employees, agents, and contractors from and against any liability and damages (including punitive damages), fees, expenses, losses, demands, and costs (including defense costs) associated with any claim arising from or relating to the Company’s knowing misrepresentations or false or incomplete

information provided to Grant Thornton. In the event of any controversy or claim against Grant Thornton arising from or related to the services described herein, Grant Thornton shall be entitled to defend itself from such controversy or claim and to participate in any settlement, administrative, or judicial proceedings.

It is expressly agreed by the Company and Grant Thornton that any claim by, or on behalf of either party, arising out of services or this Engagement Letter, whether it be in contract, tort, or otherwise, shall be deemed waived if a claim is asserted more than two (2) years from: (i) the date of the report(s) issued by Grant Thornton; or (ii) the date of this Engagement Letter if no report has been issued.

If because of a change in the Company's status or due to any other reason, any provision in this Engagement Letter would be prohibited by laws, regulations, or published interpretations by governmental bodies, commissions, state boards of accountancy, or other regulatory agencies, such provision shall, to that extent, be of no further force and effect, and the Engagement Letter shall consist of the remaining portions.

Dispute resolution

Any controversy or claim arising out of or relating to the services, related fees, or this Engagement Letter shall first be submitted to mediation. A mediator will be selected by agreement of the parties, or if the parties cannot agree, a mediator acceptable to all parties will be appointed by the American Arbitration Association ("AAA"). The mediation will proceed in accordance with the customary practice of mediation. In the unlikely event that any dispute or claim cannot be resolved by mediation, we both recognize that the matter will probably involve complex business or accounting issues that would be decided most equitably to us both by a judge hearing the evidence without a jury. Accordingly, to the extent now or hereafter permitted by applicable law, the Company and Grant Thornton agree to waive any right to a trial by jury in any action, proceeding, or counterclaim arising out of or relating to our services or this Engagement Letter.

If the above jury trial waiver is determined to be prohibited by applicable law, then the parties agree that the dispute or claim shall be settled by binding arbitration. The arbitration proceeding shall take place in the city in which the Grant Thornton office providing the relevant services is located, unless the parties mutually agree to a different location. The proceeding shall be governed by the provisions of the Federal Arbitration Act ("FAA") and will proceed in accordance with the then current Arbitration Rules for Professional Accounting and Related Disputes of the AAA, except that pre-hearing discovery must be specifically authorized by the arbitrator. The arbitrator will be selected from AAA, JAMS, the Center for Public Resources, or any other internationally or nationally-recognized organization mutually agreed upon by the parties. Potential arbitrator names will be exchanged within 15 days of the parties' agreement to settle the dispute or claim by binding arbitration, and arbitration will thereafter proceed expeditiously. The arbitration will be conducted before a single arbitrator, experienced in accounting and auditing matters. The arbitrator shall have no authority to award non-monetary or equitable relief and will not have the right to award punitive damages. The award of the arbitration shall be in writing and shall be accompanied by a well-reasoned opinion. The

award issued by the arbitrator may be confirmed in a judgment by any federal or state court of competent jurisdiction. Each party shall be responsible for their own costs associated with the arbitration, except that the costs of the arbitrator shall be equally divided by the parties. The arbitration proceeding and all information disclosed during the arbitration shall be maintained as confidential, except as may be required for disclosure to professional or regulatory bodies or in a related confidential arbitration. In no event shall a demand for arbitration be made after the date when institution of legal or equitable proceedings based on such claim would be barred under the applicable statute of limitations.

Authorization

This Engagement Letter sets forth the entire understanding between the Company and Grant Thornton regarding the services described herein and supersedes any previous proposals, correspondence, and understandings, whether written or oral. If any portion of this Engagement Letter is held invalid, it is agreed that such invalidity shall not affect any of the remaining portions.

Please confirm your acceptance of this Engagement Letter by signing below and returning one copy to us in the enclosed self-addressed envelope.

Sincerely,

GRANT THORNTON LLP



Lauren M. Spegal
Partner

Agreed and accepted by:

SOONER TOWN CENTER, LLC AND STC LOWE'S LLC



Robert C. Collett, Managing Member

Date: 1/22/19



Katherine Fox, Chief Financial Officer of Collett
As an agent of Sooner Town Center, LLC

Date: 1/23/19

MIDWEST CITY ECONOMIC
DEVELOPMENT AUTHORITY

Date: _____

Matthew Dukes II, CHAIRMAN

ATTEST:

Approved as to form and legality this ____
day of February, 2019

Sara Hancock, City Clerk

Heather Poole, City Attorney



NEW BUSINESS/
PUBLIC DISCUSSION





EXECUTIVE SESSION





Economic Development
100 N. Midwest Blvd.
Midwest City, OK 73110
rcoleman@midwestcityok.org
Office: 405-739-1218
www.midwestcityok.org

MEMORANDUM

TO: Honorable Chairman and Trustees

FROM: Robert Coleman, Economic Development Director

DATE: February 12, 2019

SUBJECT: Discussion and consideration of 1) entering into executive session, as allowed under 25 O.S. § 307(B)(3), to discuss the purchase or appraisal of real property; and 2) in open session, authorizing the general manager/ administrator to take action as appropriate based on the discussion in executive session.

Appropriate information will be dispersed during executive session.

Robert Coleman, Economic Development Director



Economic Development
100 N. Midwest Blvd.
Midwest City, OK 73110
rcoleman@midwestcityok.org
Office: 405-739-1218
www.midwestcityok.org

MEMORANDUM

TO: Honorable Chairman and Trustees

FROM: Robert Coleman, Economic Development Director

DATE: February 12, 2019

SUBJECT: Discussion and consideration of 1) entering into executive session, as allowed under 25 O.S. § 307(C)(10), to confer on matters pertaining to economic development, including the transfer of property, financing or the creation of a proposal to entice a business to remain or to locate within the City; and 2) in open session, authorizing the city manager to take action as appropriate based on the discussion in executive session.

Appropriate information will be dispersed during executive session.

Robert Coleman, Economic Development Director